



DKR02, DKR03 and DKR04 Drive Controllers

Project Planning Manual

SYSTEM200

Title DKR02, DKR03 and DKR04 Drive Controllers

Type of Documentation Project Planning Manual

Document Typecode DOK-DIAX03-DKR*****-PR02-EN-P

Internal File Reference • Document Number: 120-0700-B326-02/EN

Purpose of Documentation This document serves the purpose of:

- planning the mechanics of the control cabinet,
- planning the electrical connections,
- determining the available accessories required,
- integrating the mechanical parts into the control cabinet,
- generating the installation guidelines of the machine manufacturer and
- identifying the machines and the components.

Record of Revisions

Description	Release Date	Notes
209-0042-4130-00	July 95	1st edition
DOK-DIAX03-DKR*****-PRJ1-EN-P	Aug. 96	DKR04 included, doc. code added
DOK-DIAX03-DKR*****-PR02-EN-P	10.00	The DKR05 devices are described in a separate documentation.

Copyright © 2000 Rexroth Indramat GmbH

Copying this document, giving it to others and the use or communication of the contents thereof without express authority, are forbidden. Offenders are liable for the payment of damages. All rights are reserved in the event of the grant of a patent or the registration of a utility model or design (DIN 34-1).

Validity All rights are reserved with respect to the content of this documentation and the availability of the product.

Published by Rexroth Indramat GmbH
 Bgm.-Dr.-Nebel-Str. 2 • D-97816 Lohr a. Main
 Telephone +49 (0) 93 52/40-0 • Tx 689421 • Fax +49 (0) 93 52/40-48 85
<http://www.rexroth.com/indramat>
 Dept. ECD (SA/VS/BB)

Note This document has been printed on chlorine-free bleached paper.

Supplementary documentation

Note: The following documentation is not required in its entirety for the correct use of the drive controllers DKR.

Title	Type of Documentation	Document Typecode	Part Number
AC Drive Units in Hazardous Areas (Expl. Protection)	Instructions for Use	DOK-GENERL-ANTR*EXPLOS-ANxx-EN-P	266 304
AC Drive Units in Personnel Conveyor Systems	Instructions for Use	DOK-GENERL-ANTR*PERSON-Anxx-EN-P	266 305
Electromagnetic Compatibility (EMC) in Drive and Control Systems	Project Planning Manual	DOK-GENERL-EMV*****-PRJ*-EN-P	259 814
DIAX03/04, ECODRIVE03 AC-Hauptantriebe mit 2AD- und ADF-Motoren / AC main drives with 2AD- and ADF-motors	Auswahldaten / Selection data	DOK-DRIVE*-MAIN*WZM***-AU01-MS-P	289 233
DIAX03 Plug-in modules for digital intelligent drive controllers	Project Planning Manual	DOK-DIAX03-PLUG*IN*MOD-PRxx-EN-P	275 155
DIAX03 AC Drives for Continuous Operation (S1)	Selection data	DOK-DIAX03-PRIN*****-AUxx-EN-P	274 660
DIAX03/04, ECODRIVE03 AC-Hauptantriebe für Dauerbetrieb (S1) / AC-Drives for Continuous Operation (S1)	Auswahldaten / Selection lists	DOK-DRIVE*-PRINT*****-AUxx-MS-P	288 730
Asynchronous Linear Motors LAF	Selection Data DIAX03 / DIAX04	DOK-MOTOR*-LAF*****-AUxx-EN-P	277 353
DIAX03 ...	Drive configuration	DOK-DIAX03-xxxxxxx**-INxx-EN-P	⊕1
Indramat Internal Connection System LWL - Handling	Application Description	DOK-CONNEX-CABLE*LWL**-AWxx-EN-E	284 755

⊕1: You need this document in order to determine the drive configuration or to specify the hardware configuration labelling of a DIAX03 drive controller. It is part of a firmware box set.

x: The "x" is a replacement character.

Fig.: Supplementary documentation

Changes from previous version

Note: The following list may not be absolutely complete. The author reserves the right to make changes to this list as needed.

Where?	What?
	Supplementary documentation included
General Safety Guidelines	update
	Appropriate use added
	Record of Revisions added
	introduction of devices reorganized
Entire document	new layout
	conversion of cooling method included
	brake resistor DZB included
Entire document	data regarding other units than the ones described in this documentation replaced by cross references (cables, motors, plug-in modules)
	Sales & Service Facilities included
Chapter "Service and checks"	information on how to replace units and fault report included
Electrical connections	serial interface included
Mains connection	power circuit-breaker added
Cooling system	noise test data included
Technical data	revision

Fig.: Changes with regard to the previous version
DOK-DIAX03-DKR*****-PRJ1-EN-P

Contents

1	Important directions for use	1-1
1.1	Appropriate use	1-1
	Introduction	1-1
	Areas of use and application.....	1-2
1.2	Inappropriate use	1-2
2	Safety instructions for electric servo drives and controls	2-1
2.1	Introduction.....	2-1
2.2	Explanations.....	2-1
2.3	Hazards by inappropriate use	2-2
2.4	General information.....	2-3
2.5	Protection against contact with electrical parts.....	2-4
2.6	Protection by protective low voltage (PELV) against electrical shock	2-6
2.7	Protection against dangerous movements.....	2-6
2.8	Protection against magnetic and electromagnetic fields during operations and mounting.....	2-8
2.9	Protection against contact with hot parts	2-9
2.10	Protection during handling and installation	2-9
2.11	Battery safety	2-10
2.12	Protection against pressurized systems	2-10
3	Introducing the devices	3-1
3.1	Drive controllers	3-1
	General features	3-1
3.2	Brake resistor	3-5
4	Technical data	4-1
4.1	DKR02.....	4-1
4.2	DKR03.....	4-2
4.3	DKR04.....	4-4
4.4	DZB01	4-5
5	Planning the cabinet	5-1
5.1	Ambient conditions.....	5-1
5.2	Cooling method	5-2
	Determine energy dissipation	5-2
	Possible cooling method variants	5-4
	Use of cooling units.....	5-7
5.3	Dimension sheets.....	5-9

Required distances for cooling with air from inside the cabinet..... 5-9

DKR02..... 5-10

DKR03..... 5-12

DKR04..... 5-14

DZB01 5-16

5.4 Additional dimensions when cooling with a duct..... 5-17

5.5 Leads..... 5-20

5.6 Measures to avoid sources of interference in the control cabinet..... 5-22

6 Planning the electrical connections 6-1

6.1 Preliminary remark 6-1

6.2 Fundamental guidelines 6-1

6.3 Positions of the connectors, pin configurations and lead cross sections..... 6-2

6.4 Mains connection 6-4

 Grounded three-phase systems 6-4

 Ungrounded three-phase system 6-5

6.5 Dimensioning 6-9

 Mains fuses and lead cross sections 6-9

 Autotransformers 6-11

 Isolating transformers 6-12

 Overvoltage suppressor..... 6-13

6.6 Functions and allocations of individual interfaces..... 6-14

 X2: Serial interface..... 6-14

 X3: Analog output and signal contact 6-16

 X4: Motor feedback..... 6-17

 X6: Monitoring motor temperature and holding brakes 6-18

 X7: Signal outputs..... 6-19

 X8: Signal voltages 6-20

 X9: Control inputs for internal power contactors..... 6-21

 X5 and X10: Power voltage, control voltage and brake resistor connections 6-21

7 Accessories 7-1

7.1 Connector kits 7-1

 Connector kit for the basic unit 7-1

 Connector kit for all plug-in modules of a configuration including the feedback connections . 7-2

7.2 Fiber optic cables 7-3

7.3 Mechanical accessories 7-4

 Accessories for duct cooling 7-4

 Mounting frames 7-4

8 Transport and storage 8-1

8.1 Transport..... 8-1

8.2 Storage..... 8-1

9 Identifying the merchandise 9-1

9.1 General..... 9-1

9.2	Delivery slip and barcode sticker	9-1
9.3	Rating plate and type code of the drive controller	9-2
9.4	Type code of the auxiliary bleeders	9-4
10	Mounting and installation	10-1
10.1	Adapting the cooling method.....	10-1
	DKR02 and DKR03.....	10-1
	DKR04.....	10-3
10.2	Mounting the drive.....	10-6
10.3	Drive wiring.....	10-9
	Power connector with double cable	10-10
11	Service and checks	11-1
11.1	Error diagnoses.....	11-1
11.2	Repairing and replacing units	11-2
11.3	Fault report.....	11-4
12	Index	12-1
13	Service & Support	13-1
13.1	Helpdesk	13-1
13.2	Service-Hotline	13-1
13.3	Internet – World wide web.....	13-1
13.4	Vor der Kontaktaufnahme... - ...before contacting us...	13-1
13.5	Kundenbetreuungsstellen - Sales & Service Facilities	13-2

Notes

1 Important directions for use

1.1 Appropriate use

Introduction

Rexroth Indramat products represent state-of-the-art developments and manufacturing. They are tested prior to delivery to ensure operating safety and reliability.

The products may only be used in the manner that is defined as appropriate. If they are used in an inappropriate manner, then situations can develop that may lead to property damage or injury to personnel.

Note: Rexroth Indramat, as manufacturer, is not liable for any damages resulting from inappropriate use. In such cases, the guarantee and the right to payment of damages resulting from inappropriate use are forfeited. The user alone carries all responsibility of the risks.

Before using Rexroth Indramat products, make sure that all the prerequisites for an appropriate use of the products are satisfied:

- Personnel that in any way, shape or form uses our products must first read and understand the relevant safety instructions and be familiar with appropriate use.
- If the product takes the form of hardware, then they must remain in their original state, in other words, no structural changes are permitted. It is not permitted to decompile software products or alter source codes.
- Do not mount damaged or faulty products or use them in operation.
- Make sure that the products have been installed in the manner described in the relevant documentation.

Areas of use and application

Drive controllers made by Rexroth Indramat are designed to control electrical motors and monitor their operation.

Control and monitoring of the motors may require additional sensors and actors.

Note: The drive controllers may only be used with the accessories and parts specified in this document. If a component has not been specifically named, then it may not be either mounted or connected. The same applies to cables and lines.

Operation is only permitted in the specified configurations and combinations of components using the software and firmware as specified in the relevant function descriptions.

Every drive controller has to be parameterized while starting it up, making it possible for the motor to execute the specific functions of an application.

To ensure an application-specific use, the drive controllers are available with differing drive power and different interfaces.

Typical applications of DKR drive controllers are:

- printing machines and
- NC machine tools.

The drive controllers may only be operated under the assembly, installation and ambient conditions as described here (temperature, system of protection, humidity, EMC requirements, etc.) and in the position specified.

1.2 Inappropriate use

Using the drive controllers outside of the above-referenced areas of application or under operating conditions other than described in the document and the technical data specified is defined as "inappropriate use".

Drive controllers may not be used if

- they are subject to operating conditions that do not meet the above specified ambient conditions. This includes, for example, operation under water, in the case of extreme temperature fluctuations or extremely high maximum temperatures or if
- Rexroth Indramat has not specifically released them for that intended purpose. Please note the specifications outlined in the general safety instructions!

2 Safety instructions for electric servo drives and controls

2.1 Introduction

Read these instructions before the equipment is used and eliminate the risk of personal injury or property damage. Follow these safety instructions at all times.

Do not attempt to install, use or service this equipment without first reading all documentation provided with the product. Read and understand these safety instructions and all user documentation of the equipment prior to working with the equipment at any time. If you do not have the user documentation for your equipment contact your local Rexroth Indramat representative to send this documentation immediately to the person or persons responsible for the safe operation of this equipment.

If the product is resold, rented or transferred or passed on to others, then these safety instructions must be delivered with the product.



Inappropriate use of this equipment, failure to follow the safety instructions in this document or tampering with the product, including disabling of safety devices, may result in product damage, personal injury, severe electrical shock or death!

2.2 Explanations

The safety warnings in this documentation describe individual degrees of hazard seriousness in compliance with ANSI:

Warning symbol with signal word	Degree of hazard seriousness The degree of hazard seriousness describes the consequences resulting from non-compliance with the safety guidelines.
	Bodily harm or product damage will occur.
	Death or severe bodily harm may occur.
	Death or severe bodily harm may occur.

Fig. 2-1: Classes of danger with ANSI

2.3 Hazards by inappropriate use



DANGER

**High voltage and high discharge current!
Danger to life, risk of severe electrical shock
and risk of injury!**



DANGER

**Dangerous movements! Danger to life and risk
of injury or equipment damage by unintentional
motor movements!**



WARNING

**High electrical voltage due to wrong
connections! Danger to life, severe electrical
shock and severe bodily injury!**



WARNING

**Health hazard for persons with heart
pacemakers, metal implants and hearing aids in
proximity to electrical equipment!**



CAUTION

**Surface of machine housing could be extremely
hot! Danger of injury! Danger of burns!**



CAUTION

**Risk of injury due to inappropriate handling!
Bodily injury caused by crushing, shearing,
cutting and mechanical shock or improper
handling of pressurized systems!**



CAUTION

**Risk of injury due to inappropriate handling of
batteries!**

2.4 General information

- Rexroth Indramat GmbH is not liable for damages resulting from failure to observe the warnings given in these documentation.
- Order operating, maintenance and safety instructions in your language before starting up the machine. If you find that due to a translation error you can not completely understand the documentation for your product, please ask your supplier to clarify.
- Proper and correct transport, storage, assembly and installation as well as care in operation and maintenance are prerequisites for optimal and safe operation of this equipment.
- Trained and qualified personnel in electrical equipment:
Only trained and qualified personnel may work on this equipment or within its proximity. Personnel are qualified if they have sufficient knowledge of the assembly, installation and operation of the product as well as an understanding of all warnings and precautionary measures noted in these instructions.
Furthermore, they should be trained, instructed and qualified to switch electrical circuits and equipment on and off, to ground them and to mark them according to the requirements of safe work practices and common sense. They must have adequate safety equipment and be trained in first aid.
- Only use spare parts and accessories approved by the manufacturer.
- Follow all safety regulations and requirements for the specific application as practiced in the country of use.
- The equipment is designed for installation on commercial machinery.
European countries: see directive 89/392/EEC (machine guideline).
- The ambient conditions given in the product documentation must be observed.
- Use only safety features that are clearly and explicitly approved in the Project Planning manual.
For example, the following areas of use are not allowed: Construction cranes, Elevators used for people or freight, Devices and vehicles to transport people, Medical applications, Refinery plants, the transport of hazardous goods, Radioactive or nuclear applications, Applications sensitive to high frequency, mining, food processing, Control of protection equipment (also in a machine).
- Start-up is only permitted once it is sure that the machine, in which the product is installed, complies with the requirements of national safety regulations and safety specifications of the application.
- Operation is only permitted if the national EMC regulations for the application are met.
The instructions for installation in accordance with EMC requirements can be found in the Rexroth Indramat document "EMC in Drive and Control Systems".
The machine builder is responsible for compliance with the limiting values as prescribed in the national regulations and specific EMC regulations for the application.
European countries: see Directive 89/336/EEC (EMC Guideline).
U.S.A.: See National Electrical Codes (NEC), National Electrical Manufacturers Association (NEMA), and local building codes. The user of this equipment must consult the above noted items at all times.
- Technical data, connections and operational conditions are specified in the product documentation and must be followed at all times.

2.5 Protection against contact with electrical parts

Note: This section refers to equipment with voltages above 50 Volts.

Making contact with parts conducting voltages above 50 Volts could be dangerous to personnel and cause an electrical shock. When operating electrical equipment, it is unavoidable that some parts of the unit conduct dangerous voltages.



DANGER

High electrical voltage! Danger to life, severe electrical shock and severe bodily injury!

- ⇒ Only those trained and qualified to work with or on electrical equipment are permitted to operate, maintain or repair this equipment.
- ⇒ Follow general construction and safety regulations when working on electrical installations.
- ⇒ Before switching on power the ground wire must be permanently connected to all electrical units according to the connection diagram.
- ⇒ Do not operate electrical equipment at any time if the ground wire is not permanently connected, even for brief measurements or tests.
- ⇒ Before working with electrical parts with voltage potentials higher than 50 V, the equipment must be disconnected from the mains voltage or power supply.
- ⇒ The following should be observed with electrical drives, power supplies, and filter components:
Wait five (5) minutes after switching off power to allow capacitors to discharge before beginning work. Measure the voltage on the capacitors before beginning work to make sure that the equipment is safe to touch.
- ⇒ Never touch the electrical connection points of a component while power is turned on.
- ⇒ Install the covers and guards provided with the equipment properly before switching the equipment on. Prevent contact with live parts at any time.
- ⇒ A residual-current-operated protective device (r.c.d.) must not be used on an electric drive! Indirect contact must be prevented by other means, for example, by an overcurrent protective device.
- ⇒ Equipment that is built into machines must be secured against direct contact. Use appropriate housings, for example a control cabinet.

European countries: according to EN 50178/1998, section 5.3.2.3.

U.S.A: See National Electrical Codes (NEC), National Electrical Manufacturers Association (NEMA) and local building codes. The user of this equipment must observe the above noted instructions at all times.

To be observed with electrical drives, power supplies, and filter components:



DANGER

**High electrical voltage! High leakage current!
Danger to life, danger of injury and bodily harm
from electrical shock!**

- ⇒ Before switching on power for electrical units, all housings and motors must be permanently grounded according to the connection diagram. This applies even for brief tests.
- ⇒ Leakage current exceeds 3.5 mA. Therefore the electrical equipment and units must always be firmly connected to the supply network.
- ⇒ Use a copper conductor with at least 10 mm² cross section over its entire course for this protective connection!
- ⇒ Prior to startups, even for brief tests, always connect the protective conductor or connect with ground wire. High voltage levels can occur on the housing that could lead to severe electrical shock and personal injury.

European countries: EN 50178/1998, section 5.3.2.1.

USA: See National Electrical Codes (NEC), National Electrical Manufacturers Association (NEMA), and local building codes. The user of this equipment must maintain the above noted instructions at all times.

2.6 Protection by protective low voltage (PELV) against electrical shock

All connections and terminals with voltages between 5 and 50 Volts on INDRAMAT products are protective low voltages designed in accordance with the following standards on contact safety:

- International: IEC 364-4-411.1.5
- EU countries: see EN 50178/1998, section 5.2.8.1.



WARNING

High electrical voltage due to wrong connections! Danger to life, severe electrical shock and severe bodily injury!

- ⇒ Only equipment, electrical components and cables of the protective low voltage type (PELV = Protective Extra Low Voltage) may be connected to all terminals and clamps with 0 to 50 Volts.
 - ⇒ Only safely isolated voltages and electrical circuits may be connected. Safe isolation is achieved, for example, with an isolating transformer, an opto-electronic coupler or when battery-operated.
-

2.7 Protection against dangerous movements

Dangerous movements can be caused by faulty control or the connected motors. These causes are be various such as:

- unclean or wrong wiring of cable connections
- inappropriate or wrong operation of equipment
- malfunction of sensors, encoders and monitoring circuits
- defective components
- software errors

Dangerous movements can occur immediately after equipment is switched on or even after an unspecified time of trouble-free operation.

The monitors in the drive components make faulty operation almost impossible. Regarding personnel safety, especially the danger of bodily harm and property damage, this alone should not be relied upon to ensure complete safety. Until the built-in monitors become active and effective, it must be assumed in any case that some faulty drive movements will occur. The extent of these faulty drive movements depends upon the type of control and the state of operation.

**DANGER****Dangerous movements! Danger to life and risk of injury or equipment damage!**

⇒ Personnel protection must be secured for the above listed reason by means of superordinate monitors or measures.

These are instituted in accordance with the specific situation of the facility and a danger and fault analysis conducted by the manufacturer of the facility. All the safety regulations that apply to this facility are included therein. By switching off, circumventing or if safety devices have simply not been activated, then random machine movements or other types of faults can occur.

Avoiding accidents, injury or property damage:

⇒ Keep free and clear of the machine's range of motion and moving parts. Prevent people from accidentally entering the machine's range of movement:

- use protective fences
- use protective railings
- install protective coverings
- install light curtains or light barriers

⇒ Fences must be strong enough to withstand maximum possible momentum.

⇒ Mount the emergency stop switch (E-stop) in the immediate reach of the operator. Verify that the emergency stop works before startup. Don't operate the machine if the emergency stop is not working.

⇒ Isolate the drive power connection by means of an emergency stop circuit or use a start-inhibit system to prevent unintentional start-up.

⇒ Make sure that the drives are brought to standstill before accessing or entering the danger zone.

⇒ Secure vertical axes against falling or slipping after switching off the motor power by, for example:

- Mechanically securing the vertical axes
- Adding an external brake / clamping mechanism
- Balancing and thus compensating for the vertical axes mass and the gravitational force

The standard equipment motor brake or an external brake controlled directly by the servo drive are not sufficient to guarantee the safety of personnel!

- ⇒ Disconnect electrical power to the equipment using a master switch and secure the switch against reconnection for:
 - maintenance and repair work
 - cleaning of equipment
 - long periods of discontinued equipment use
 - ⇒ Avoid operating high-frequency, remote control and radio equipment near electronics circuits and supply leads. If use of such equipment cannot be avoided, verify the system and the plant for possible malfunctions at all possible positions of normal use before the first start-up. If necessary, perform a special electromagnetic compatibility (EMC) test on the plant.
-

2.8 Protection against magnetic and electromagnetic fields during operations and mounting

Magnetic and electromagnetic fields generated by current-carrying conductors and permanent magnets in motors represent a serious health hazard to persons with heart pacemakers, metal implants and hearing aids.



WARNING

- Health hazard for persons with heart pacemakers, metal implants and hearing aids in proximity to electrical equipment!**
- ⇒ Persons with pacemakers, metal implants and hearing aids are not permitted to enter following areas:
 - Areas in which electrical equipment and parts are mounted, being operated or started up.
 - Areas in which parts of motors with permanent magnets are being stored, operated, repaired or mounted.
 - ⇒ If it is necessary for a person with a pacemaker to enter such an area, then a physician must be consulted prior to doing so. Pacemakers, that are already implanted or will be implanted in the future, have a considerable deviation in their resistance to interference. Due to the unpredictable behavior there are no rules with general validity.
 - ⇒ Persons with hearing aids, metal implants or metal pieces must consult a doctor before they enter the areas described above. Otherwise health hazards will occur.
-

2.9 Protection against contact with hot parts



CAUTION

**Housing surfaces could be extremely hot!
Danger of injury! Danger of burns!**

- ⇒ Do not touch surfaces near the source of heat! Danger of burns!
 - ⇒ Wait ten (10) minutes before you access any hot unit. Allow the unit to cool down.
 - ⇒ Do not touch hot parts of the equipment, such as housings, heatsinks or resistors. Danger of burns!
-

2.10 Protection during handling and installation

Under certain conditions inappropriate handling and installation of parts and components may cause injuries.



CAUTION

**Risk of injury through incorrect handling!
Bodily harm caused by crushing, shearing,
cutting and mechanical shock!**

- ⇒ Observe general instructions and safety regulations during handling installation.
 - ⇒ Use only appropriate lifting or moving equipment.
 - ⇒ Take precautions to avoid pinching and crushing.
 - ⇒ Use only appropriate tools. If specified by the product documentation, special tools must be used.
 - ⇒ Use lifting devices and tools correctly and safely.
 - ⇒ Wear appropriate protective clothing, e.g. safety glasses, safety shoes and safety gloves.
 - ⇒ Never stay under suspended loads.
 - ⇒ Clean up liquids from the floor immediately to prevent personnel from slipping.
-

2.11 Battery safety

Batteries contain reactive chemicals in a solid housing. Inappropriate handling may result in injuries or equipment damage.



CAUTION

Risk of injury through incorrect handling!

- ⇒ Do not attempt to reactivate discharged batteries by heating or other methods (danger of explosion and corrosion).
- ⇒ Never charge batteries (danger from leakage and explosion).
- ⇒ Never throw batteries into a fire.
- ⇒ Do not dismantle batteries.
- ⇒ Handle with care. Incorrect extraction or installation of a battery can damage equipment.

Note: Environmental protection and disposal! The batteries contained in the product should be considered as hazardous material for land, air and sea transport in the sense of the legal requirements (danger of explosion). Dispose batteries separately from other refuse. Observe the legal requirements given in the country of installation.

2.12 Protection against pressurized systems

Certain Motors (ADS, ADM, 1MB etc.) and drives, corresponding to the information in the Project Planning manual, must be provided with and remain under a forced load such as compressed air, hydraulic oil, cooling fluid or coolant. In these cases, improper handling of the supply of the pressurized systems or connections of the fluid or air under pressure can lead to injuries or accidents.



CAUTION

Danger of injury when pressurized systems are handled by untrained personnel!

- ⇒ Do not attempt to disassemble, to open or to cut a pressurized system.
- ⇒ Observe the operation restrictions of the respective manufacturer.
- ⇒ Before the disassembly of pressurized systems, lower pressure and drain off the fluid or gas.
- ⇒ Use suitable protective clothing (for example protective eyewear, safety shoes and gloves)
- ⇒ Remove any fluid that has leaked out onto the floor immediately.

Note: Environmental protection and disposal! The fluids used in the operation of the pressurized system equipment is not environmentally compatible. Fluid that is damaging to the environment must be disposed of separate from normal waste. Observe the national specifications of the country of installation.

3 Introducing the devices

3.1 Drive controllers

General features

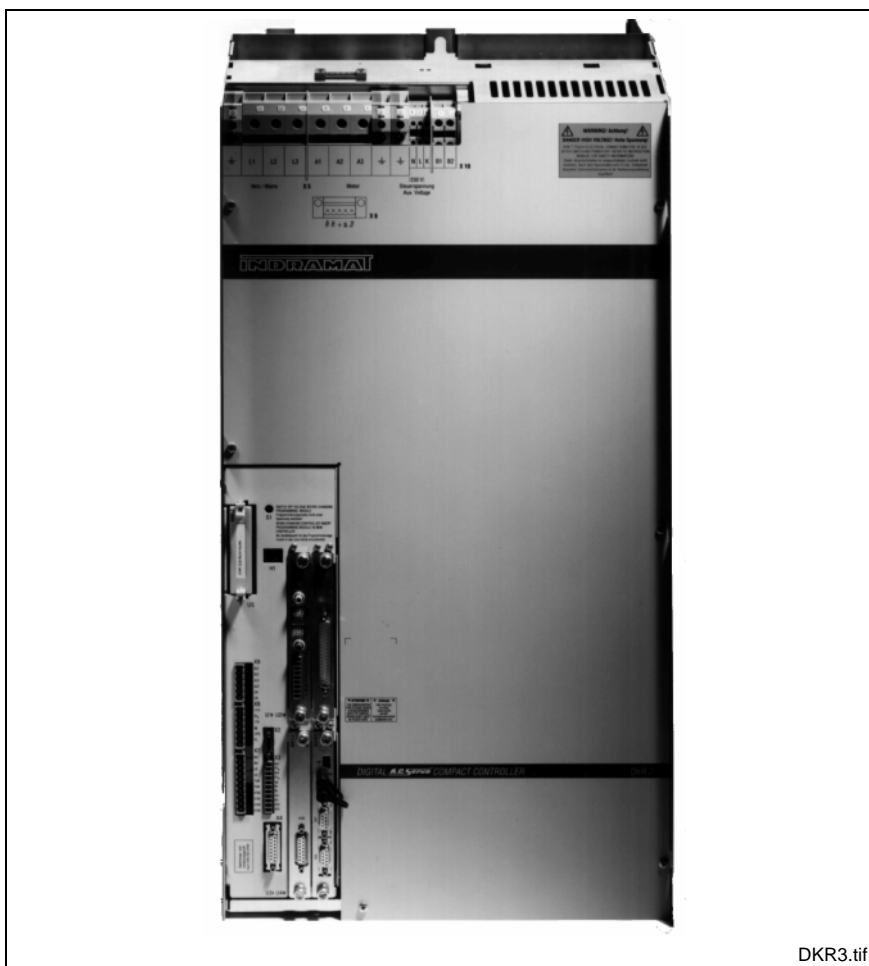

Fig. 3-1: The DKR03 drive controller

Application range

Drive controllers of the DKR type have been designed for digital intelligent control of the following Rexroth Indramat motors:

- a.c. main spindle motors 2AD or ADF,
- frameless spindle motors 1MB and
- linear motors LSF or LAF.

The output of these motors is between 10 and 93 kW of continuous power at the motor output shaft.

For precise control and regulation of the motors there are DKR drive controllers with different power ratings available.

Drives equipped with the DKR drive controller feature

- a high level of control and
- a broad speed range with constant power.

They are, for example, especially well-suited for use in

- NC-controlled machine tools or
- printing machines.

- Mains connection** DKR drive controllers have been designed for direct mains connection to grounded AC mains with 3xAC 400 V ... 480 V.
- They are equipped with an integrated mains contactor and an emergency stop shutdown device.
- Regenerated braking energy is supplied to the mains again – also in case of emergency stop.
- DKR02 and DKR03 devices can be ordered with an **integrated** brake resistor, the DKR04 device can be expanded by an **external** brake resistor. This allows decelerating a drive even if the mains fails.
- Cooling variants** Heatsink and blower are already integrated into the housing. The cooling air is conducted through the machine in an air duct. This type of construction means that whichever cooling variant is selected, it can be quickly adapted to all demands and requirements, as, for example,
- with air from inside the control enclosure,
 - with air from outside the control enclosure or
 - cooling with a duct.
- Configuring the drive controller** Various components, i.e., modules, are available for insertion into the basic unit of the DKR. It is by means of these components that the DKR can be adapted to a specific application, e.g., an already mounted measuring encoder.
- The basic unit is adapted to your application by fitting individual plug-in cards into slots U1 through U5. Rexroth Indramat delivers the unit completely configured. A configured drive consists of:
- the basic unit,
 - a software module,
 - command interface card(s) and
 - auxiliary plug-in module(s).
- Three name plates are mounted to make sure that the configured drive is clearly labeled. See chapter 9.3 for details.
- A configured DKR must be ordered with the required firmware, i.e., FWA-DIAX03-.... . Each firmware version is a subitem and must be ordered separately.
- The firmware is the operating software of the DKR which is installed in the form of EPROMs on the DSM software modules and, if necessary, on an auxiliary plug-in module.

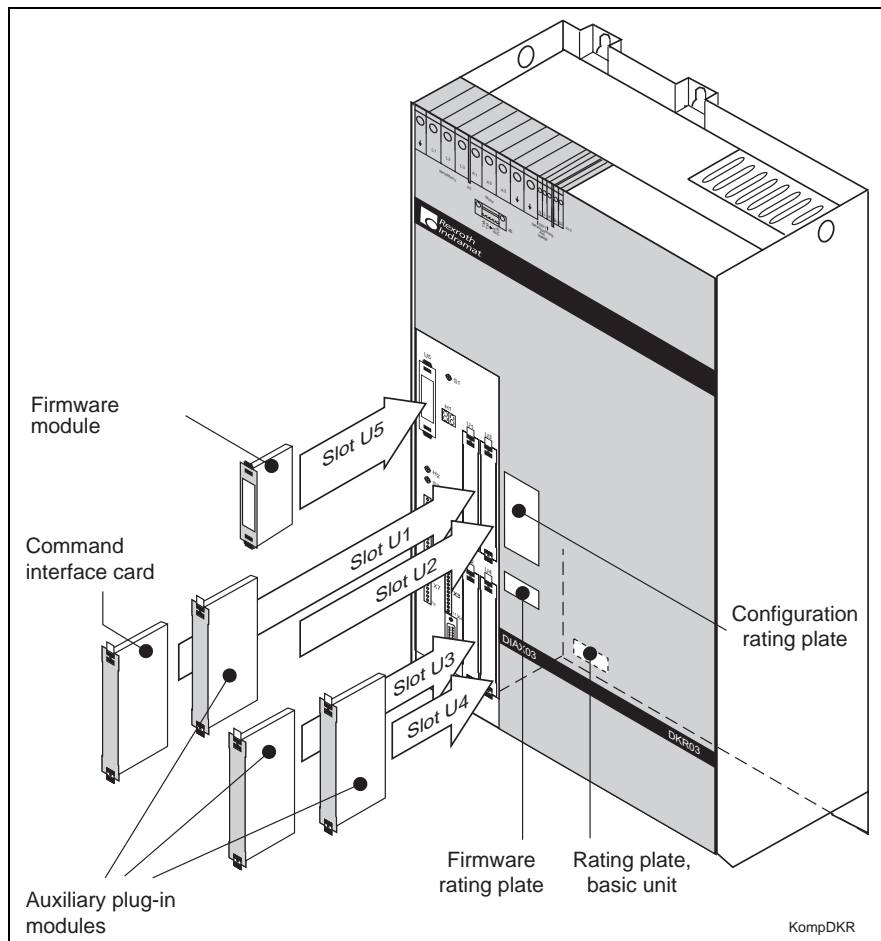

Fig. 3-2: The components of a configured drive controller

The individual components are:

Basic unit
Firmware module

In a basic unit there are no plug-in cards in slots U1 through U5.

The firmware module is denominated ESM02.3. The firmware of the drive, i.e., the operating software, is on the firmware module. All drive parameters are stored there. Select the firmware in terms of the configuration selected and the features. It is dependent on them.

In the event that the unit must be replaced, all existing drive parameters can be transmitted to the replacement unit simply by inserting the firmware module. This means that the drive is immediately available to operate with all its specific features.

Note: The command interface cards and auxiliary plug-in modules currently available are listed below. The document on the plug-in modules (see "Supplementary documentation") will give you more detailed information on the features of the modules.

For the type of plug-in modules and firmware that can be combined please refer to the document "Drive configuration".

Command interface card

Command interface cards with the following interfaces are currently available:

- SERCOS interface,
- Profibus interface,
- INTERBUS interface and
- analog interface.

Auxiliary plug-in modules Auxiliary plug-in modules with the following features are currently available:

- modules with digital I/Os for bidirectional data exchange,
- modules for different types of measuring systems:
 - incremental measuring systems with square-wave signal output
 - incremental measuring systems with sinusoidal signal output
 - singleturn encoder measuring systems
 - multiturn absolute encoders with SSI signal output
 - Rexroth Indramat toothed wheel encoders
 - measuring systems with analog power signals
- analog signal interface,
- modules with CLC link interface

3.2 Brake resistor

In case of mains failure the function of the brake resistor is to absorb the energy released by braking operations. This allows stopping the motor in a controlled way, also in case of mains failure.

DKR04.1 Devices of type DKR04.1 with option "E" (DKR04.1-WxxxE) offer the possibility to connect a brake resistor (type: DZB01.1-W720N). The electronic control system for the brake resistor is situated in the drive controller of the devices equipped with this option. The brake resistor itself has to be ordered separately and connected externally to the drive controller.

Note: Devices of type DKR04.1-WxxxE are ready for operation only with brake resistor DZB01.1-W720N!

DKR02.1 and DKR03.1 As an option, devices DKR02.1 and DKR03.1 are available with integrated brake resistor.

Notes

4 Technical data

4.1 DKR02

Designation	Symbol	Unit	Designation of the drive controller	
			DKR02.1-W200-... DKR02.1-F200-...	DKR02.1-W300-... DKR02.1-F300-...
Rated power voltage	U_{N1}	V	3xAC 400 ... 480, $\pm 10\%$	
System frequency	f_{N1}	Hz	50 ... 60	
Control voltage	U_{N2}	V	AC 230 V, $\pm 10\%$	
Control voltage frequency	f_{N2}	Hz	50 ... 60	
Control voltage power	P_{N2}	VA	200	
Continuous current of the drive (4 kHz/8 kHz)*	I_{conteff}	A	4 kHz: 120 8 kHz: 95	4 kHz: 141 8 kHz: 110
Peak current of the drive	I_{maxeff}	A	141	212
Continuous power of the drive (4 kHz/8 kHz)* (as relates to the driven shaft of motor, at 3xAC 400 V, -5%)	P_{cont}	kW	4 kHz: ca. 47 8 kHz: ca. 37	4 kHz: ca. 55 8 kHz: ca. 43
Peak power of the drive (4 kHz/8 kHz)* (as relates to the driven shaft of motor, at 3xAC 400 V, -5%)	P_{max}	kW	ca. 55	ca. 93
Continuous regenerated power	$P_{\text{rück}}$	kW	ca. 37	ca. 43
Peak regenerated power (max. 10 s) (as relates to the driven shaft of motor)	$P_{\text{rückmax}}$	kW	ca. 55	ca. 93
Drive controller power voltage	U_{eff}	V	0 ... 380	
max. frequency of the power voltage (4 kHz/8 kHz)*	f_{max}	Hz	4 kHz: 800 8 kHz: 1600	
Total heat dissipation at I_{conteff}	P_{Vges}	W	1600	1800
Heat dissipation in air channel or with coolant at I_{conteff}	P_{Vext}	W	1000	1200
Auxiliary brake resistor (Option)				
max. braking energy of the brake resistor	W	kWs	240	
Continuous power of the brake resistor	P_{BD}	kW	1,5	
Peak power of the brake resistor	P_{BS}	kW	90	
Cooling method			build-in blower / coolant	
Weight				
Drive controller	m	kg	ca. 104	
Accessories kit M1-RAC 3	m	kg	1,7	

Ambient conditions			
Perm. ambient temp. range with rated data	T_{A1}	°C	+5 ... +45
Max. perm. ambient temp. with derating of nominal data to 80%	T_{A2}	°C	+55
Storage and shipping temperature	T_L	°C	-30 ... +80
Max. installation elevation without nominal data derating		m/sea lev.	0 ... 1000
Protection category			IP 20 per EN60529 / IEC529

*: Tact frequency of the power section

Fig. 4-1: Technical data DKR02

4.2 DKR03

Designation	Symbol	Unit	Designation of the drive controller	
			DKR03.1-W100-... DKR03.1-F100-...	DKR03.1-W200-... DKR03.1-F200-...
Rated power voltage	U_{N1}	V	3xAC 400 ... 480, ± 10%	
System frequency	f_{N1}	Hz	50 ... 60	
Control voltage	U_{N2}	V	AC 230 V, ± 10%	
Control voltage frequency	f_{N2}	Hz	50 ... 60	
Control voltage power	P_{N2}	VA	200	
Continuous current of the drive (4 kHz/8 kHz)*	I_{conteff}	A	4 kHz: 71 8 kHz: 60	4 kHz: 92 8 kHz: 78
Peak current of the drive	I_{maxeff}	A	71	141
Continuous power of the drive (4 kHz/8 kHz)* (as relates to the driven shaft of motor, at 3xAC 400 V, -5%)	P_{cont}	kW	4 kHz: ca. 26 8 kHz: ca. 22	4 kHz: ca. 35 8 kHz: ca. 30
Peak power of the drive (4 kHz/8 kHz)* (as relates to the driven shaft of motor, at 3xAC 400 V, -5%)	P_{max}	kW	ca. 26	ca. 55
Continuous regenerated power	$P_{\text{rück}}$	kW	ca. 22	ca. 30
Peak regenerated power (max. 10 s) (as relates to the driven shaft of motor)	$P_{\text{rückmax}}$	kW	ca. 26	ca. 55
Drive controller power voltage	U_{eff}	V	0 ... 380	
max. frequency of the power voltage (4 kHz/8 kHz)*	f_{max}	Hz	4 kHz: 800 8 kHz: 1600	
Total heat dissipation at I_{conteff}	$P_{V\text{ges}}$	W	900	1200
Heat dissipation in air channel or with coolant at I_{conteff}	$P_{V\text{ext}}$	W	600	800

Auxiliary brake resistor (Option)			
max. braking energy of the brake resistor	W	kWs	150
Continuous power of the brake resistor	P_{BD}	kW	1
Peak power of the brake resistor	P_{BS}	kW	40
Cooling method			build-in blower
Weight			
Drive controller	m	kg	approx. 49
Accessories kit M1-RAC 3	m	kg	1,7
Ambient conditions			
Perm. ambient temp. range with rated data	T_{A1}	°C	+5 ... +45
Max. perm. ambient temp. with derating of nominal data to 80%	T_{A2}	°C	+55
Storage and shipping temperature	T_L	°C	-30 ... +80
Max. installation elevation without nominal data derating		m/sea lev.	0 ... 1000
Protection category			IP 20 per EN60529 / IEC529

*: Tact frequency of the power section

Fig. 4-2: Technical data DKR03

4.3 DKR04

Designation	Symbol	Unit	Designation of the drive controller	
			DKR04.1-W300-... DKR04.1-F300-...	DKR04.1-W400-... DKR04.1-F400-...
Rated power voltage	U_{N1}	V	3xAC 400 ... 480, $\pm 10\%$	
System frequency	f_{N1}	Hz	50 ... 60	
Control voltage	U_{N2}	V	AC 230 V, $\pm 10\%$	
Control voltage frequency	f_{N2}	Hz	50 ... 60, ± 2 Hz	
Control voltage power	P_{N2}	VA	300	
Continuous current of the drive (4 kHz/8 kHz)*	I_{conteff}	A	4 kHz: 185 8 kHz: 130	4 kHz: 210 8 kHz: 150
Peak current of the drive	I_{maxeff}	A	212	282
Continuous power of the drive (4 kHz/8 kHz)* (as relates to the driven shaft of motor, at 3xAC 400 V, -5%)	P_{cont}	kW	4 kHz: ca. 82 8 kHz: ca. 58	4 kHz: ca. 93 8 kHz: ca. 66
Peak power of the drive (4 kHz/8 kHz)* (as relates to the driven shaft of motor, at 3xAC 400 V, -5%)	P_{max}	kW	ca. 92	ca. 125
Continuous regenerated power	$P_{\text{rück}}$	kW	ca. 58	ca. 66
Peak regenerated power (max. 10 s) (as relates to the driven shaft of motor)	$P_{\text{rückmax}}$	kW	ca. 92	ca. 125
Drive controller power voltage	U_{eff}	V	0 ... 380	
max. frequency of the power voltage (4 kHz/8 kHz)*	f_{max}	Hz	4 kHz: 800 8 kHz: 1600	
Total heat dissipation at I_{conteff}	$P_{V_{\text{ges}}}$	W	2250	2500
Heat dissipation in air channel or with coolant at I_{conteff}	$P_{V_{\text{ext}}}$	W	1700	1800
Cooling method			build-in blower	
Weight				
Drive controller	m	kg	approx. 150	
Accessories kit M1-RAC 3	m	kg	1,7	
Ambient conditions				
Perm. ambient temp. range with rated data	T_{A1}	°C	+5 ... +45	
Max. perm. ambient temp. with derating of nominal data to 80%	T_{A2}	°C	+55	
Storage and shipping temperature	T_L	°C	-30 ... +80	
Max. installation elevation without nominal data derating		m/sea level	0 ... 1000	
Protection category			IP 20 per EN60529 / IEC529	

*: Tact frequency of the power section

Fig. 4-3: Technical data DKR04

4.4 DZB01

Designation	Symbol	Unit	Designation of the auxiliary brake resistor
			DZB01.1-W720N
Resistor	R	Ω	1,8
Continuous power	P _{Cont}	kW	3
Peak power	P _{Max}	kW	200
max. braking energy		kWs	720
Cooling method			build-in blower
Voltage of the blower	U _{Lü}	V	DC 24 V, \pm 20%
Current of the blower	I _{Lü}	A	0,22
Weight			
Auxiliary brake resistor	m	kg	15,3
Ambient conditions			
Perm. ambient temp. range with rated data	T _{A1}	°C	+5 ... +45
Max. perm. ambient temp. with derating of nominal data to 80%	T _{A2}	°C	+55
Storage and shipping temperature	T _L	°C	-30 ... +80
Max. installation elevation without nominal data derating		m/sea lev.	0 ... 1000
Protection category			IP 20 per EN60529 / IEC529

Fig. 4-4: Technical data DZB01

Notes

5 Planning the cabinet

5.1 Ambient conditions

Ambient temperature and installation elevation

The nominal data (see chapter 4) are valid for

- ambient temperatures from +5° to +45° C and
- installation elevation from 0 to 1000 m above sea level.

Note: In case you want to use the drive controller under other ambient conditions than the indicated ones (up to a maximum of +55 °C ambient temperature and/or a maximum installation elevation of 5000 m above sea level), you have to consider the load capacity. The power data are reduced by the load capacity.



Damage caused by use under non-specified ambient conditions!

⇒ Drive controllers which are being operated under other ambient conditions than the specified ones might be damaged. Any claim under guarantee will expire.



Damage caused by overloading of the drive controller!

⇒ In case you want to use the drive controllers for others than the indicated ambient conditions, make sure the load capacity is sufficient. For the purpose of verification please see the load capacity on the diagrams in Fig. 5-1 and follow the subsequent instructions!

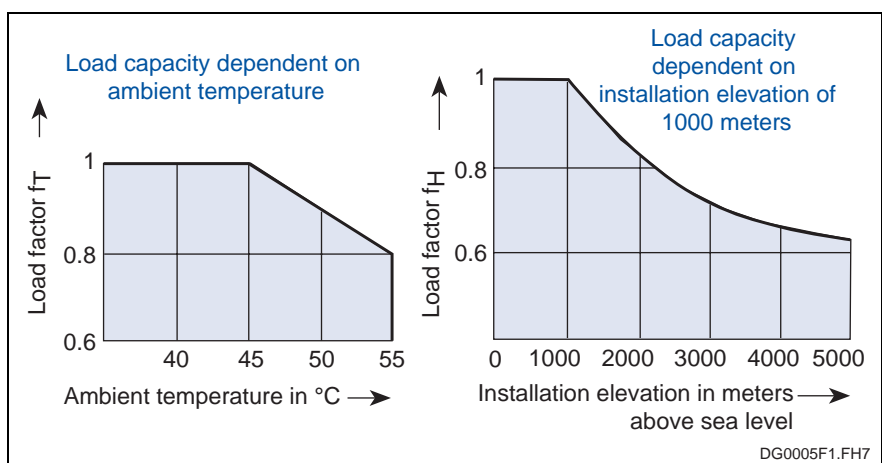

Fig. 5-1: Load capacity dependent on ambient temperature and installation elevation

Case 1:

The ambient temperature exceeds the nominal data

- or -

the installation elevation exceeds the nominal data:

1. Determine the load capacity by means of the above figure.
2. Multiply the nominal data indicated in the Technical Data by the determined load capacity.
3. Make sure the reduced nominal data are not exceeded by your application.

Case 2:

The ambient temperature exceeds the nominal data

- and -

the installation elevation exceeds the nominal data:

1. Determine the load capacity by means of the above figure.
2. Multiply the determined load capacity.
3. Multiply the nominal data indicated in the Technical Data by the load capacity calculated in step 2.
4. Make sure the reduced nominal data are not exceeded by your application.

Protection category The drive itself meets the requirements set for protection category IP20 as defined in EN 60 529, edition dated 10.91 (DIN VDE 0470-1).

Installation of the drive controller The drive controller has been designed for mounting into a cabinet or closed housing as per DIN VDE 0160, edition dated 05.88 sections 5.5.1.3 and 6.5.1.3).

Note: When laying out the cabinet remember to take the applicable safety guidelines for protection against contact into account. For industrial equipment, see EN 60 204 / DIN VDE 0113, part 1).

Shock resistance Due to the built-in main contactor, resistance to shock (rectangular shock pulses) is limited to:

- 8,4 g for 5 ms
- 4,8 g for 10 ms

5.2 Cooling method

Determine energy dissipation

When operating, the drive dissipates energy not only via the air vents at the top of the housing but also via the built-in heatsink. This is emitted in the form of heat.

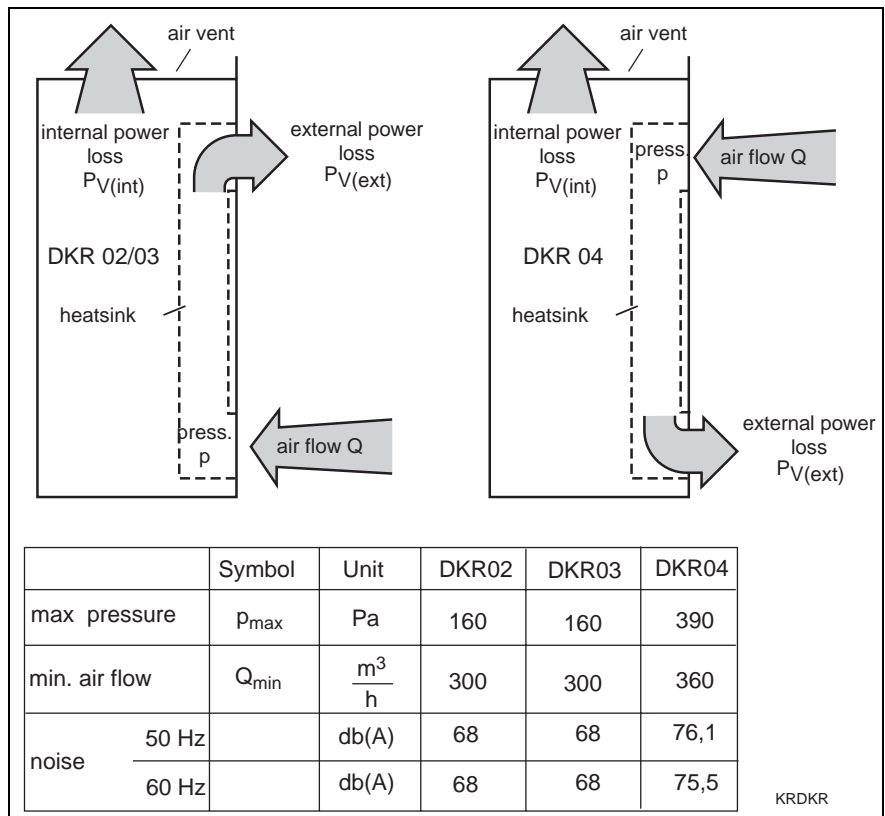

Fig. 5-2: Energy dissipated, air flow data and noise emissions

The energy dissipated both internally and externally is load-dependent. To correctly dimension the cabinet or cooling equipment, it is necessary to know the individual energy losses. Using the nominal current of the motor used and the switching frequencies which have been set, it is possible to estimate the energy losses of the DKR using the following diagram:

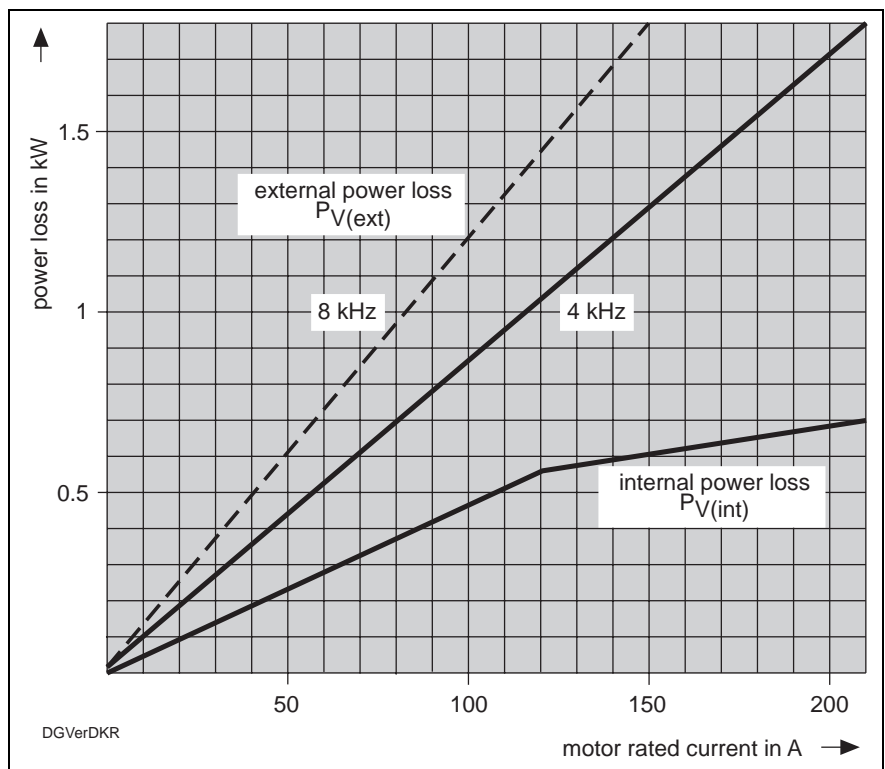

Fig. 5-3: Determining energy losses

Possible cooling method variants

The design of the devices offers several possibilities to cool the drive controller:

- with air from inside the cabinet
- with air from outside the cabinet
- duct cooling

Note: The details on how to adapt the various cooling methods are outlined in section 10.1.

Cooling with air from inside the cabinet

If the drive controller is cooled with air from inside the cabinet, then the air flow is pulled in and blown out inside the cabinet. The entire loss of energy remains within the cabinet. The cabinet protection category is not affected by this cooling method.

Cooling with air from outside the cabinet

If the drive controller is cooled with air from outside the cabinet, then the air is pulled in and blown out via vents in the back wall of the cabinet. This cooling method conducts approximately 2/3 of total energy dissipation to outside of the cabinet.



CAUTION

Damage to the drive controller by intake of polluted air outside the control cabinet!

⇒ The intake for the air outside the control cabinet mustn't be situated near the machining room, in order to rule out that the fan takes in metal dust and/or cooling agent.

If there should be any doubt in this respect, then cooling with air from inside the cabinet is recommended.



CAUTION

Overheating of the drive controller caused by dirty air inlet or heatsink!

⇒ Use appropriate filters in the air inlet.



CAUTION

Overheating of the drive controller caused by insufficient air inlet and outlet!

⇒ Make sure the dimensions of the air inlets are large enough.

⇒ For duct cooling please remember: keep the ducts as short as possible and do not use more than two 90° bends per duct.

⇒ Control the values of the cooling air flow Q and the maximum admissible overpressure p_{\max} ! You will find the admissible limit values in Fig. 5-2.

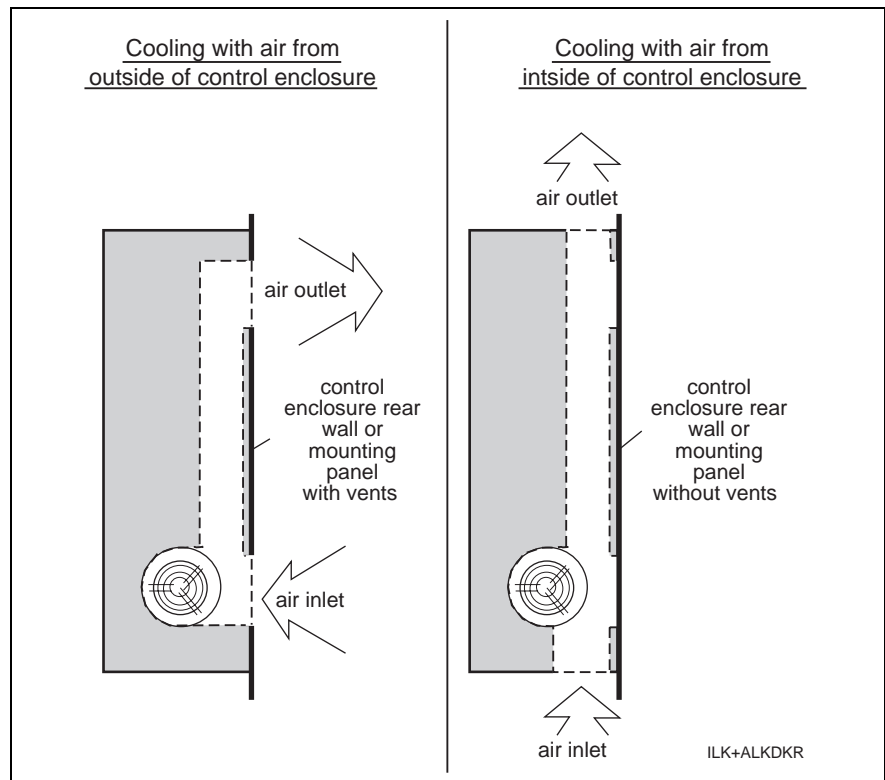

Fig. 5-4: Cooling with air inside or outside the cabinet

Cooling via duct

If the drive controller is cooled via duct, the air flow is taken in and out by two different ducts. This cooling method is recommended if it is impossible to position the vents on the rear wall of the cabinet directly at the corresponding positions of the rear wall of the drive.

Note: The components required for mounting -- with the exception of the duct itself -- are supplied in the form of a kit. The ducts can also be ordered from Rexroth Indramat upon request.

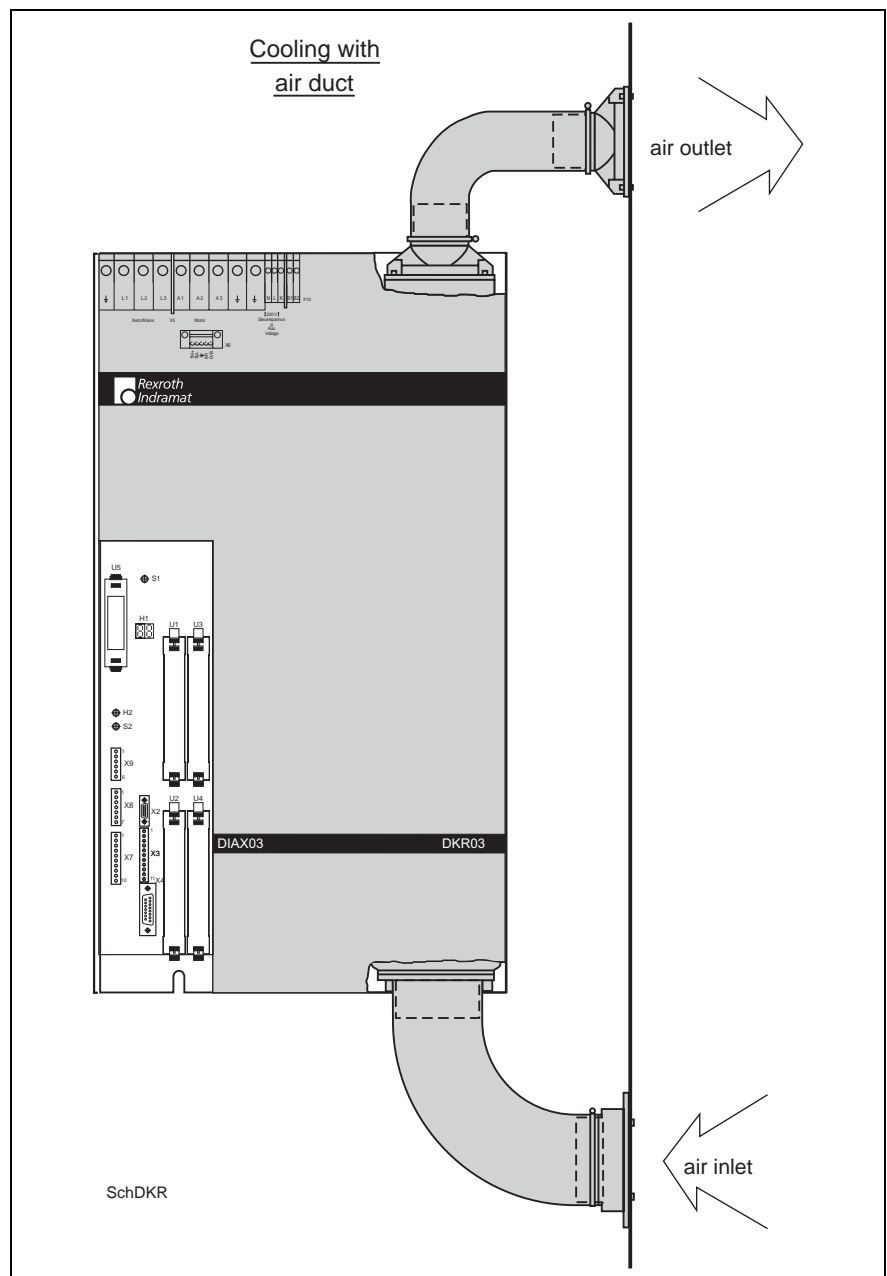

Fig. 5-5: Cooling method via duct (the example shown is a DKR03)

Cooling with air from outside the cabinet or with a duct affects the protection category of the cabinet because such methods mean that there must be vents in the cabinet. If mounting has been performed as per the guidelines, then the interior of the cabinet has a protection category of IP54.

Use of cooling units

The drive may be operated without reduction of drive data up to an ambient temperature of 45°C. Exceeding this may mean that it might be necessary to use a heat exchanger.

Avoiding water that drips or is sprayed

When using heat exchangers condensed water is produced due to the design!



CAUTION

When using heat exchangers condensed water might damage the drive controller!

- ⇒ Always arrange heat exchangers in such a way that condensation water cannot drip onto the electronic equipment within the cabinet.
- ⇒ Construct the heat exchanger in such a way that the blower of the heat exchanger cannot spray onto the electronic equipment any condensation water which might have collected.

Note: For the arrangement of heat exchangers please also observe the following figures.

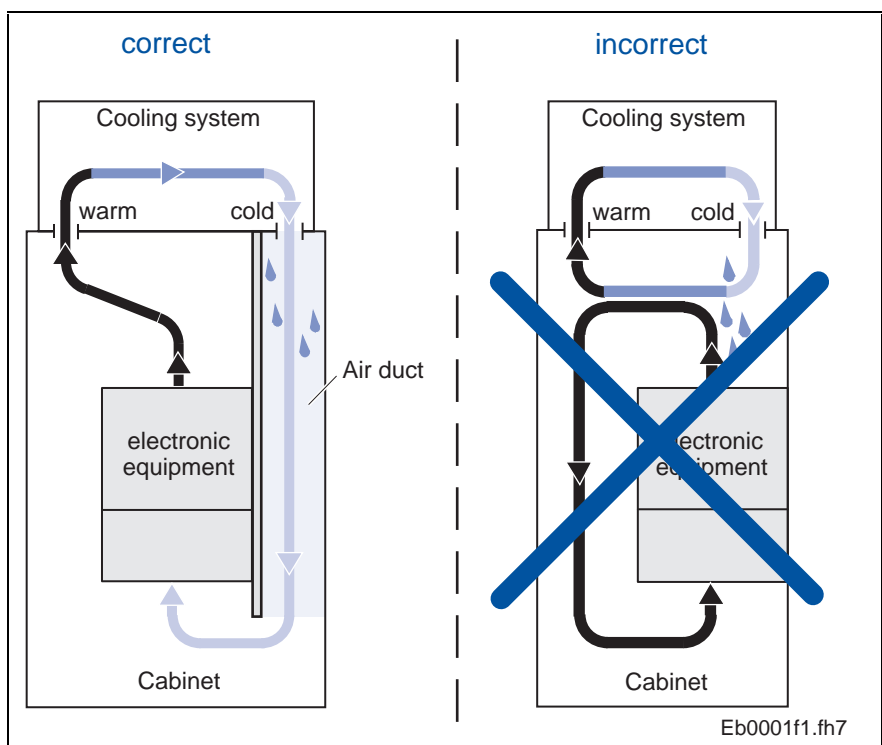

Fig. 5-6: Arranging the heat exchanger on the top of the control cabinet

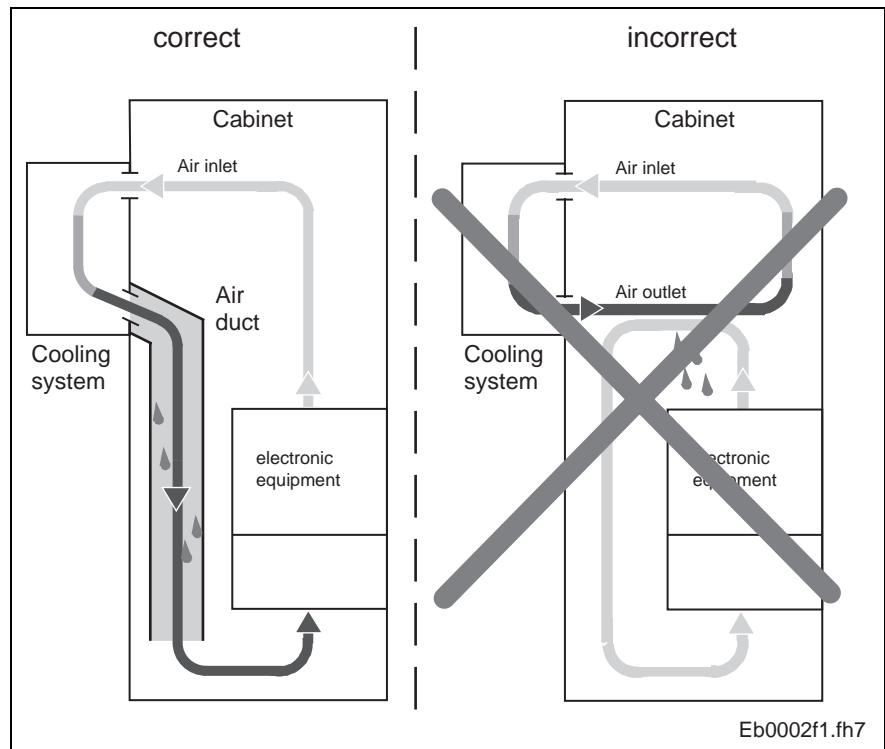

Fig. 5-7: Arranging the heat exchanger on the front of the control cabinet

Avoiding moisture condensate



CAUTION

When using heat exchangers the drive controller might be damaged by moisture condensate!

- ⇒ Set heat exchangers with a "permanent" temperature setting to at least 40° C.
- ⇒ Set heat exchangers with integrated temperature control in such a way that the inside temperature of the control cabinet is not lower than the outside temperature. Set the temperature limit to 40 °C!
- ⇒ Use only sealed cabinets. If the cabinet is poorly sealed, then moisture condensate can form at the leaky points.
- ⇒ If cabinets are operated over an extended period with the door open, e.g., during commissioning or servicing, then the drives may, at no point in time after the doors are closed, be permitted to be cooler than the air inside the cabinet. This means that heat exchangers must always be operated, even after the machine is shutdown, until the temperature of the air inside the cabinet and all installed equipment are the same.

5.3 Dimension sheets



Damage to devices caused by wrong mounting position!

⇒ In order to avoid damage to the devices caused by wrong mounting position, only install the devices in accordance with the indicated mounting positions.

Required distances for cooling with air from inside the cabinet

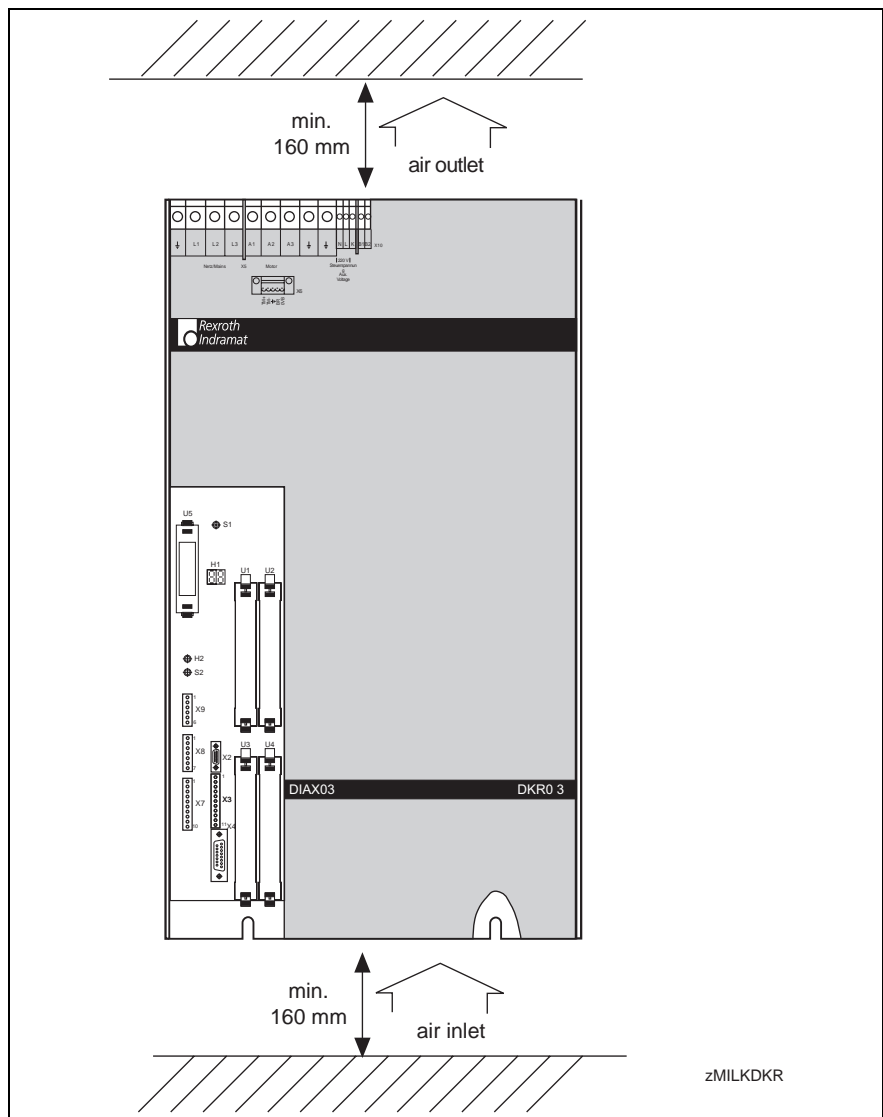

Fig. 5-8: Required distances for cooling with air from inside the cabinet

DKR02

Unit dimensions

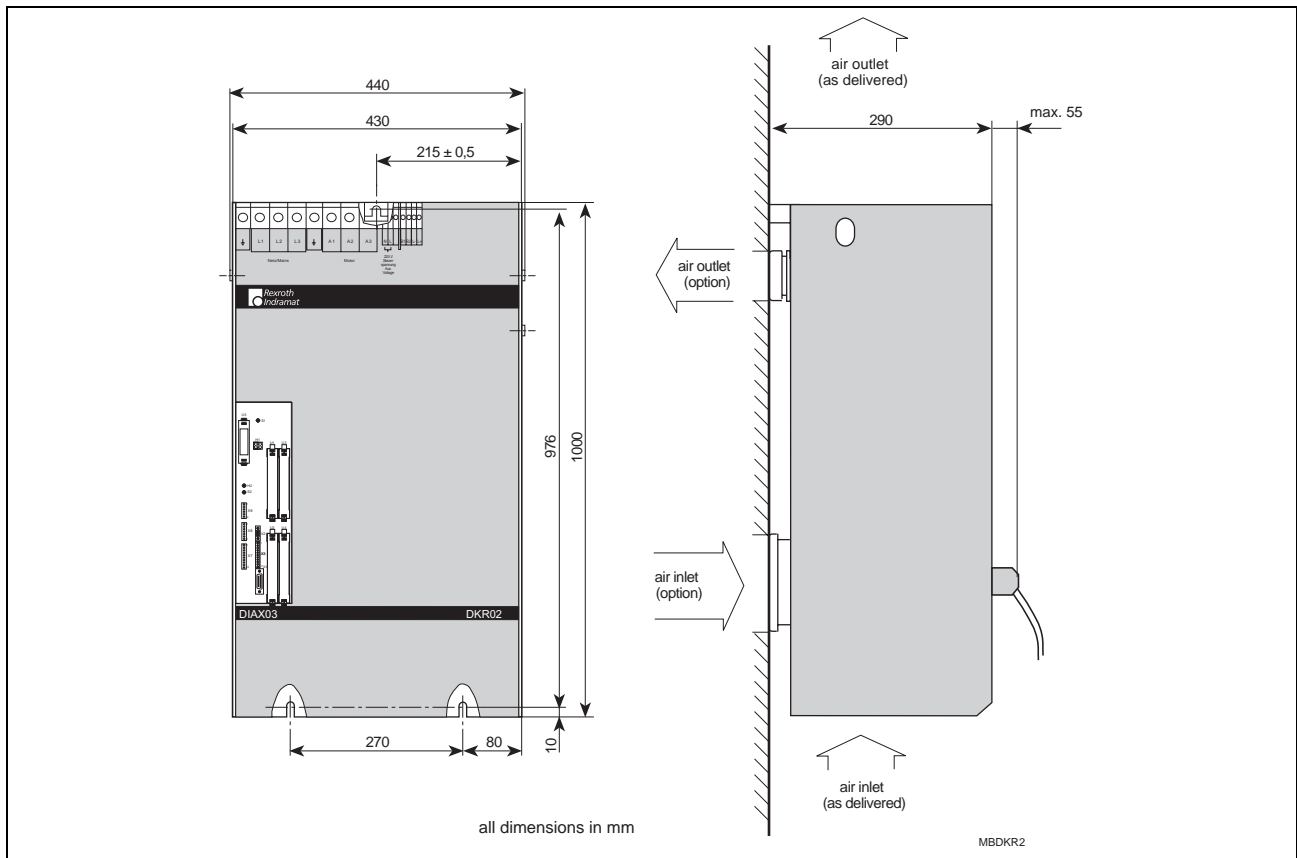

Fig. 5-9: Unit dimensions DKR02

Distances, drill diagram and vents

Note: The vents in the back wall of the cabinet or mounting panel are only required if the drive is cooled with air from outside the unit.

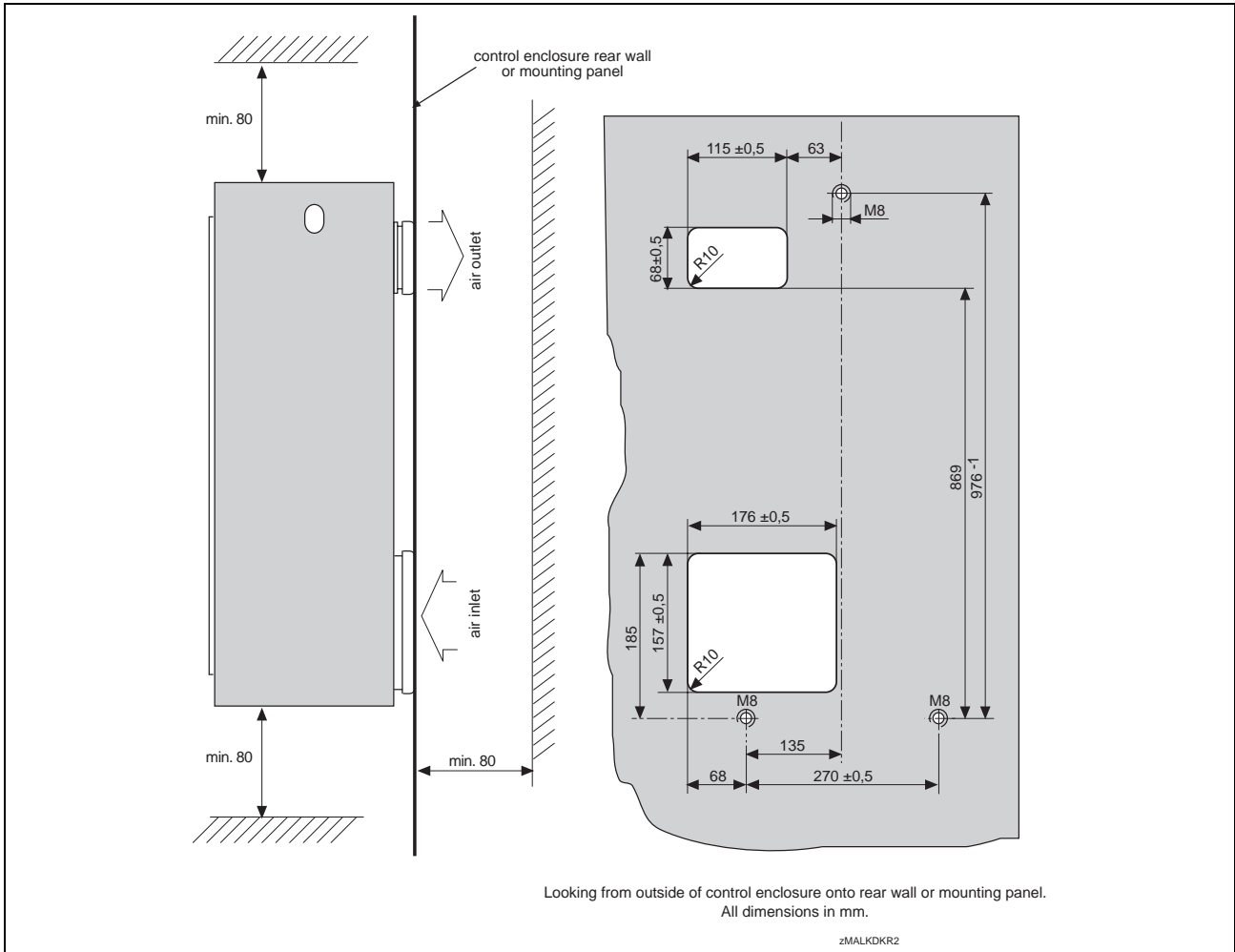

Fig. 5-10: Distances, drill diagram and vents for the DKR 02

DKR03

Unit dimensions

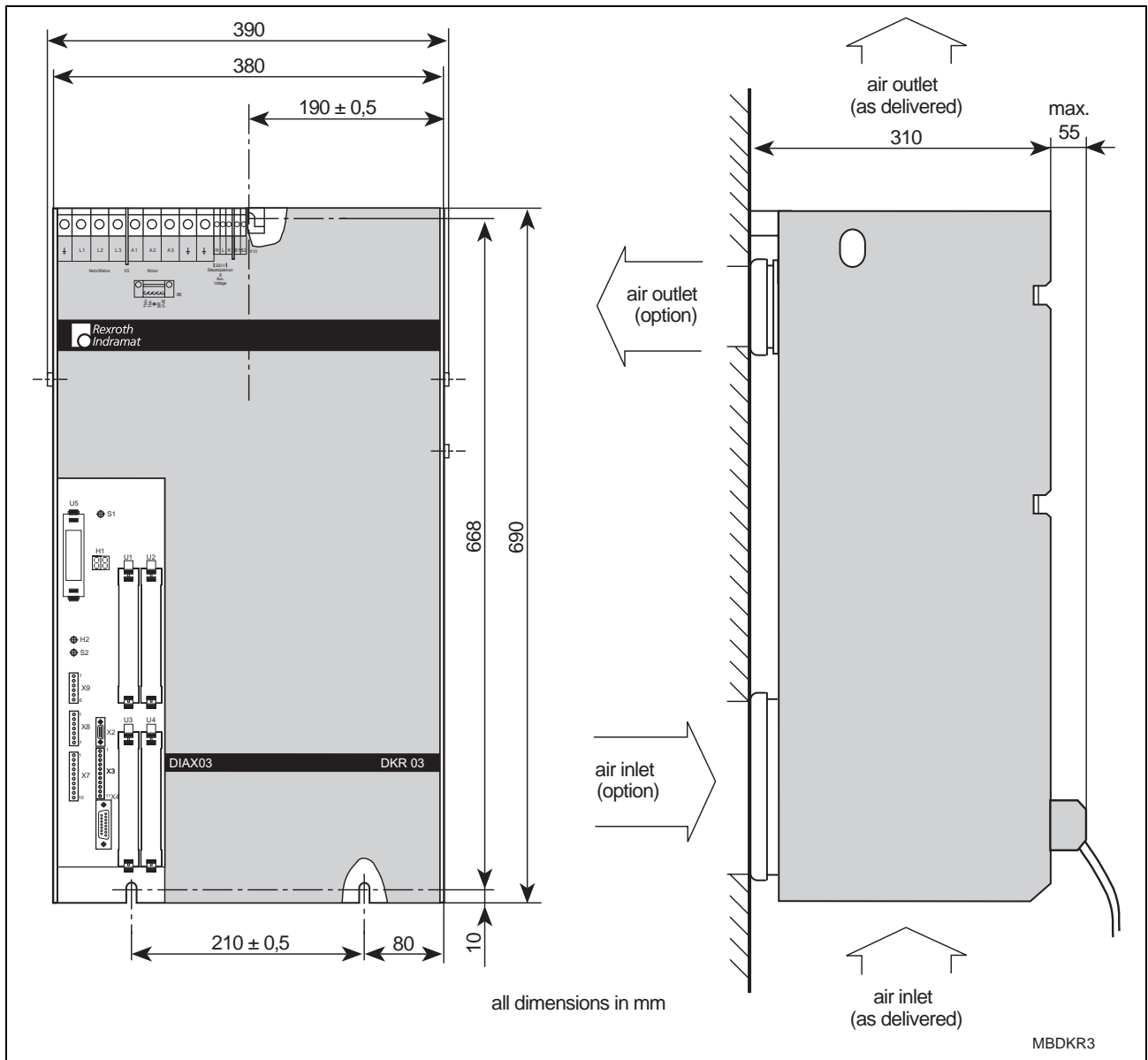

Fig. 5-11: Unit dimensions DKR03

Distances, drill diagram and vents

Note: The vents in the back wall of the cabinet or mounting panel are only required if the drive is cooled with air from outside the unit.

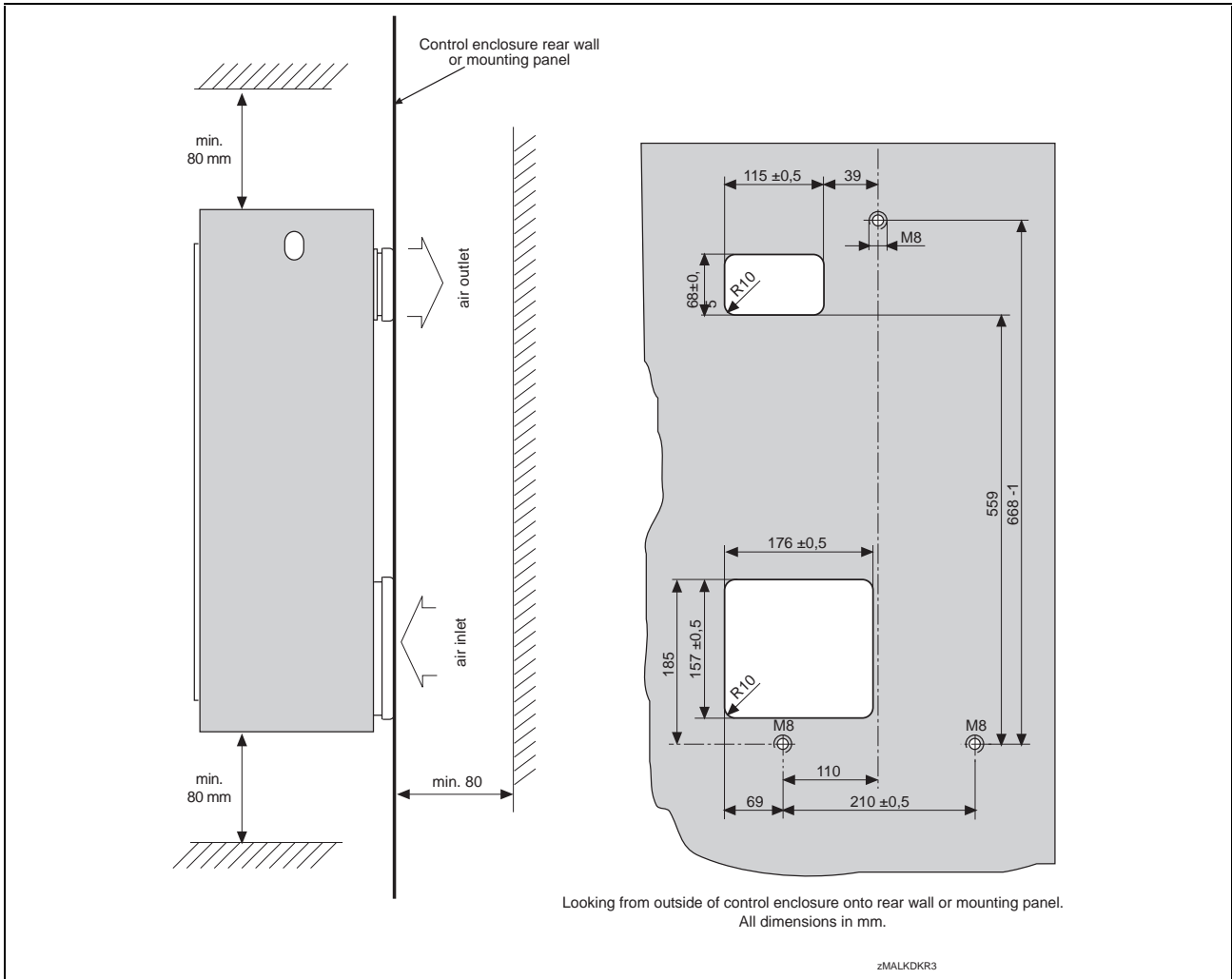

Fig. 5-12: Distances, drill diagram and vents for DKR03

DKR04

Note: If the cooling method implementing outside air is used, and the rear wall or mounting panel are "thin", then it is recommended to mount with frame **M1-RAC4**. This additional frame helps to stabilize the mounting surface.

Unit dimensions

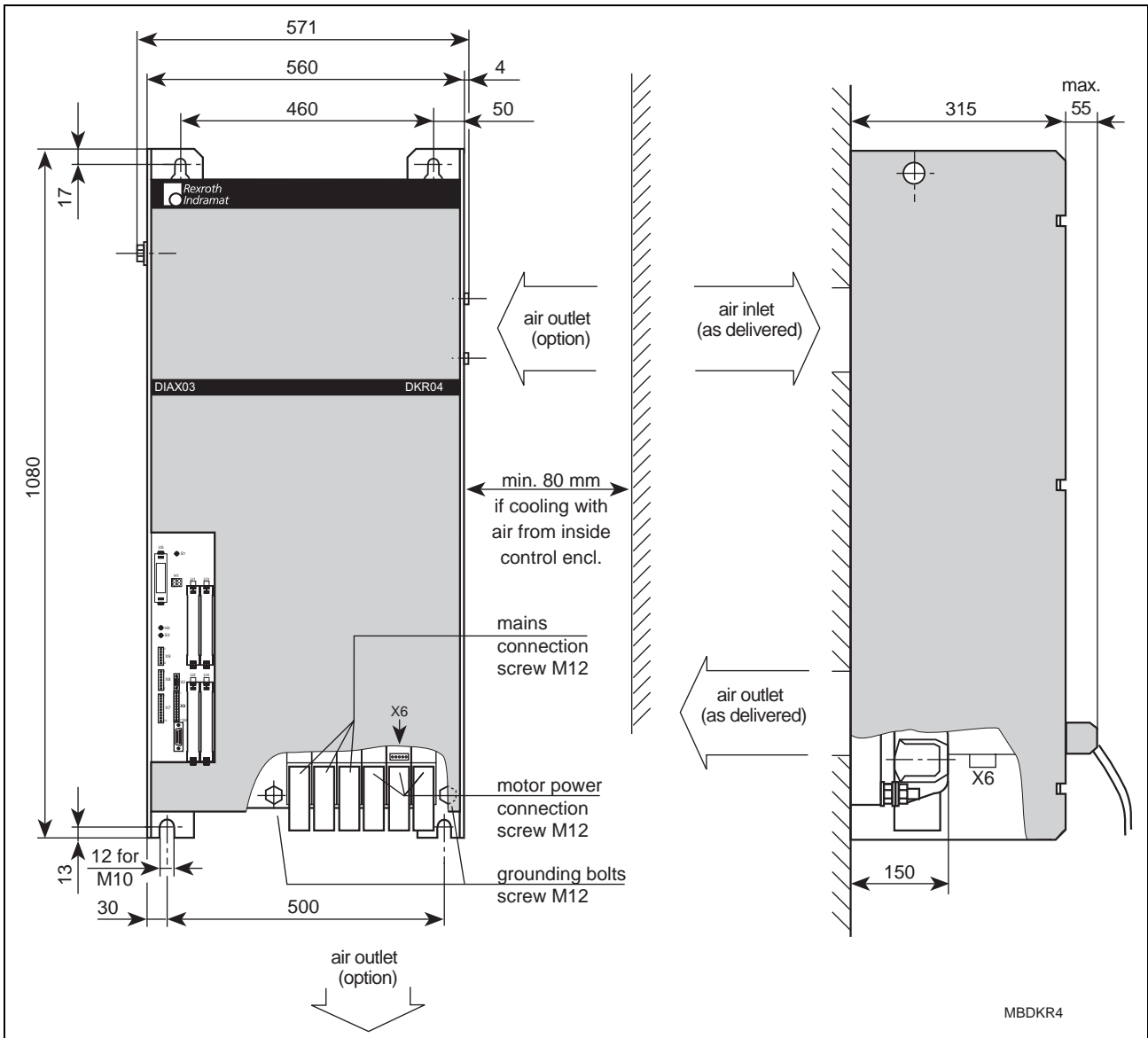

Fig. 5-13: Unit dimensions DKR04

Distances, drill diagram and vents

Note: The vents in the back wall of the cabinet or mounting panel are only required if the drive is cooled with air from outside the unit.

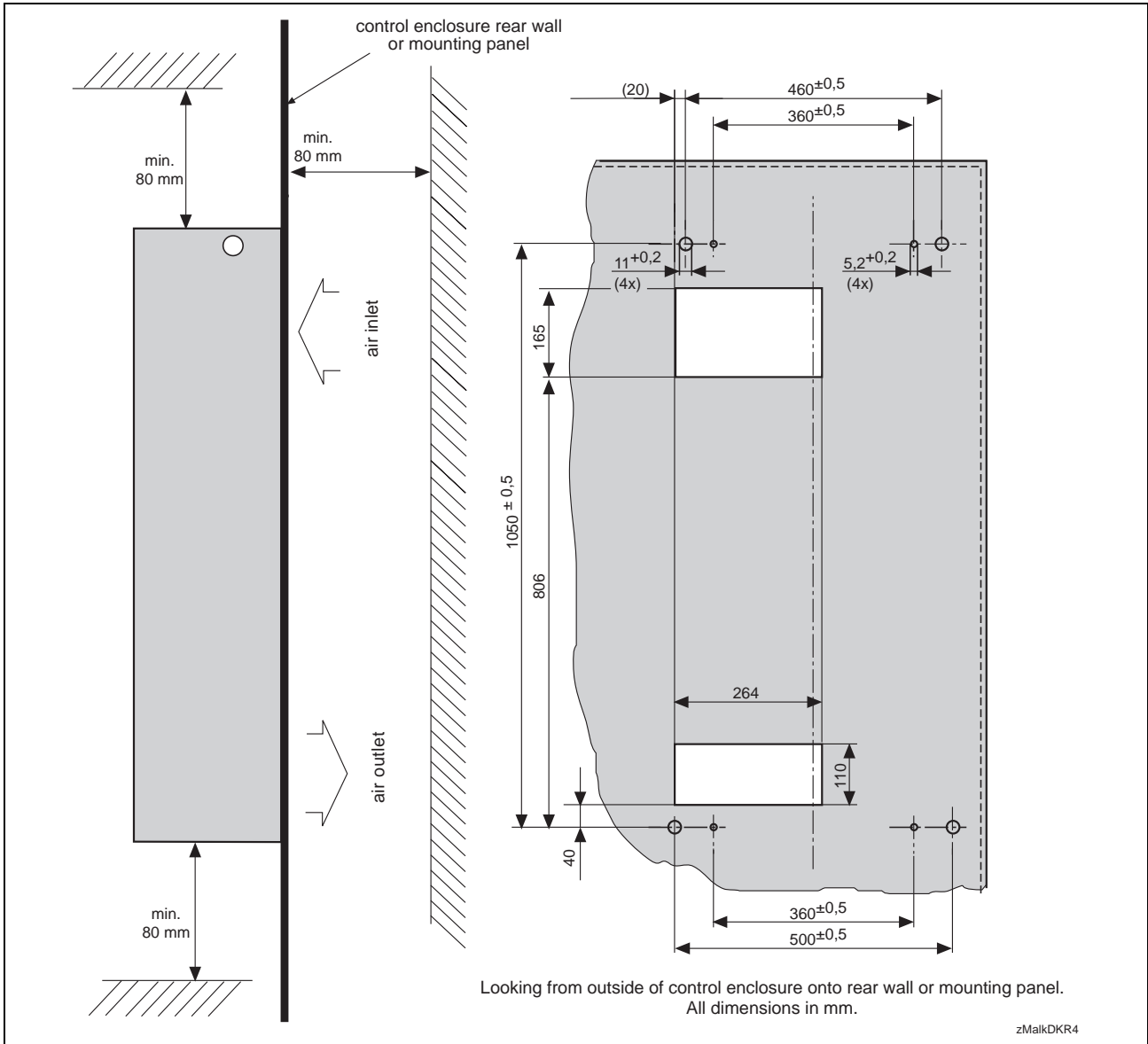

Fig. 5-14: Distances, drill diagram and vents for DKR04

DZB01

Unit dimensions

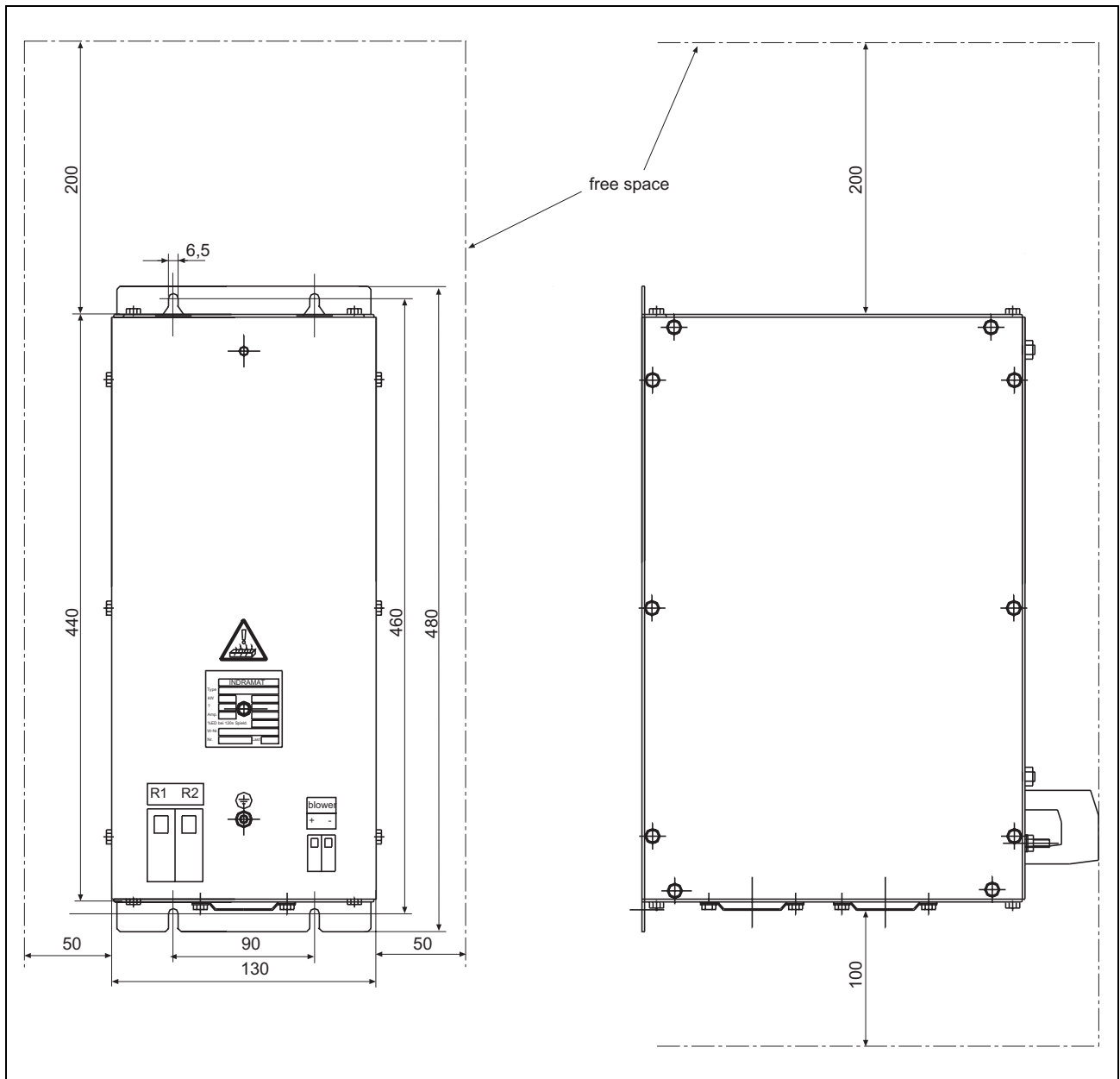

Fig. 5-15: Unit dimensions DZB01

5.4 Additional dimensions when cooling with a duct

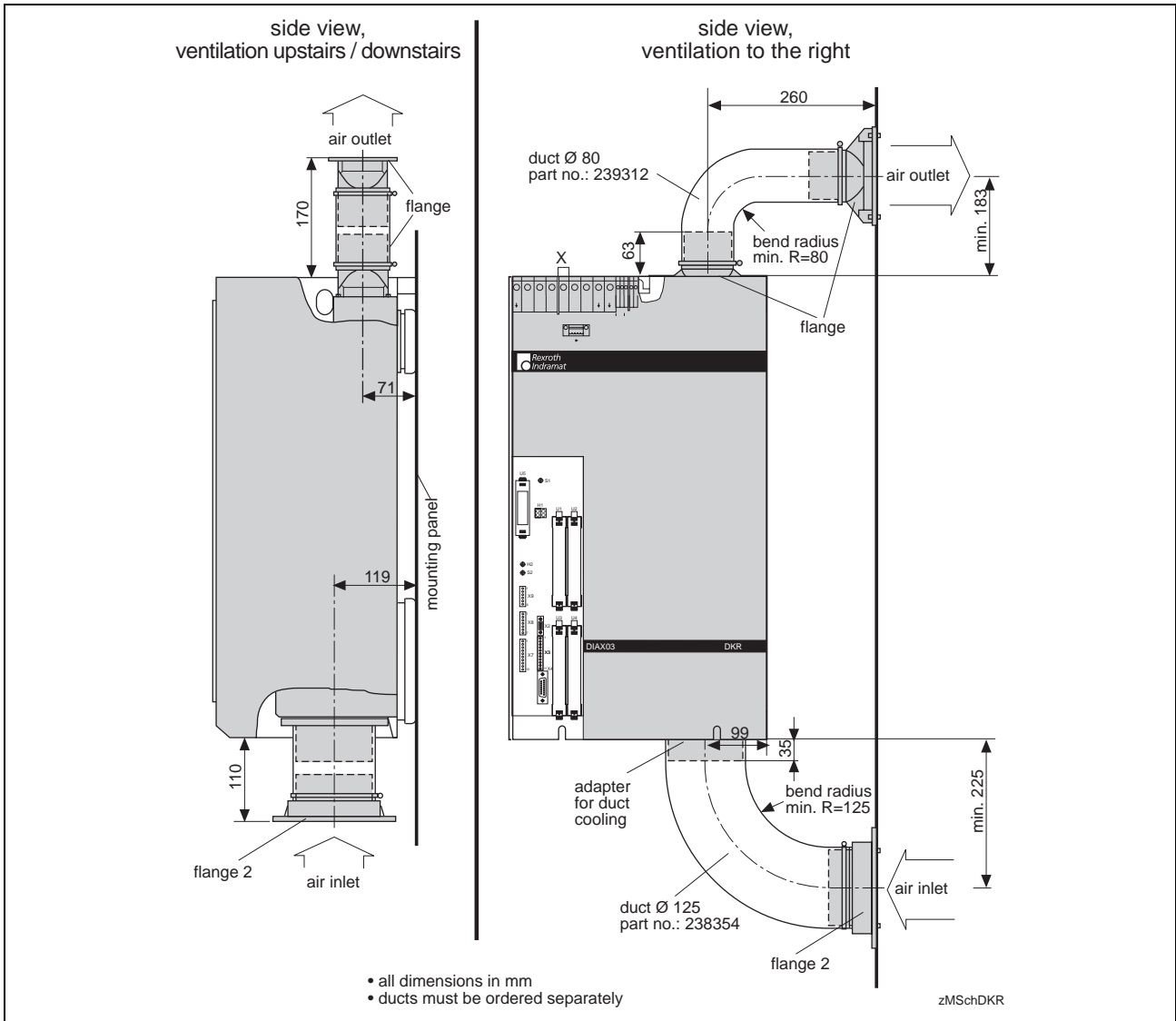

Fig. 5-16: Additional dimensions when cooling with a duct - DKR02/DKR03

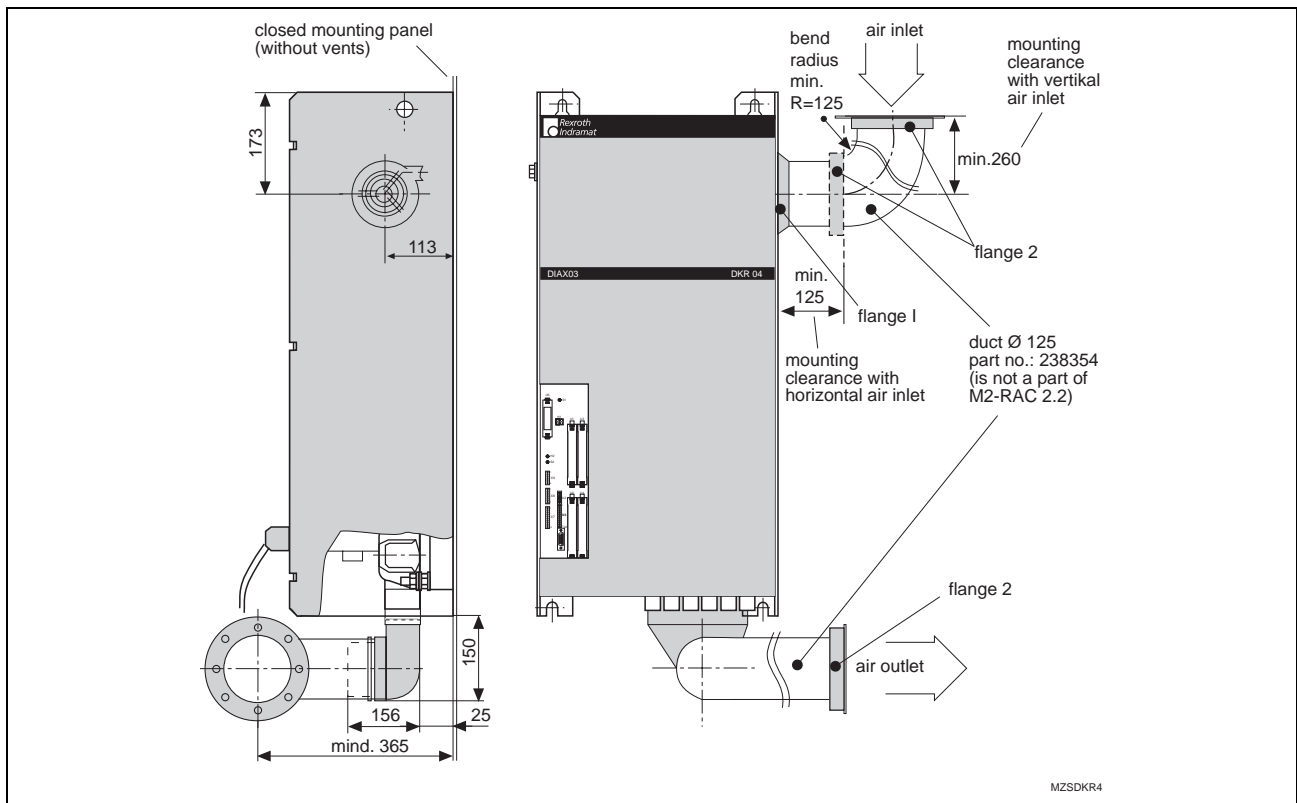

Fig. 5-17: Additional dimensions when cooling with a duct - DKR04

Note: All parts required for mounting, including screws, gaskets, flanges, ... are included in the mechanical accessories kit **M2-RAC 2.2**.

The ducts are not included in the mechanical accessories kit but Rexroth Indramat can also supply them upon request.

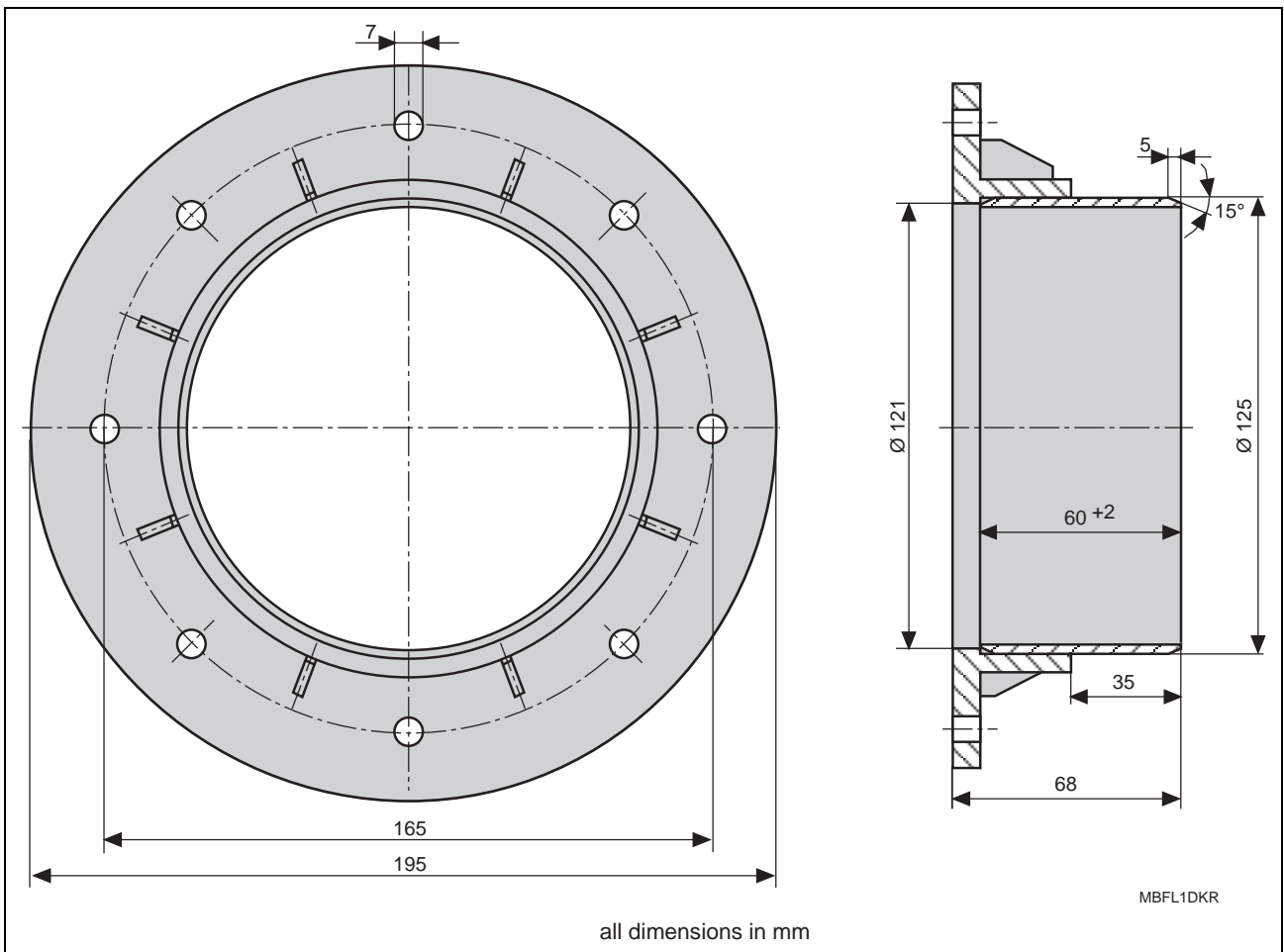

Fig. 5-18: Flange 2

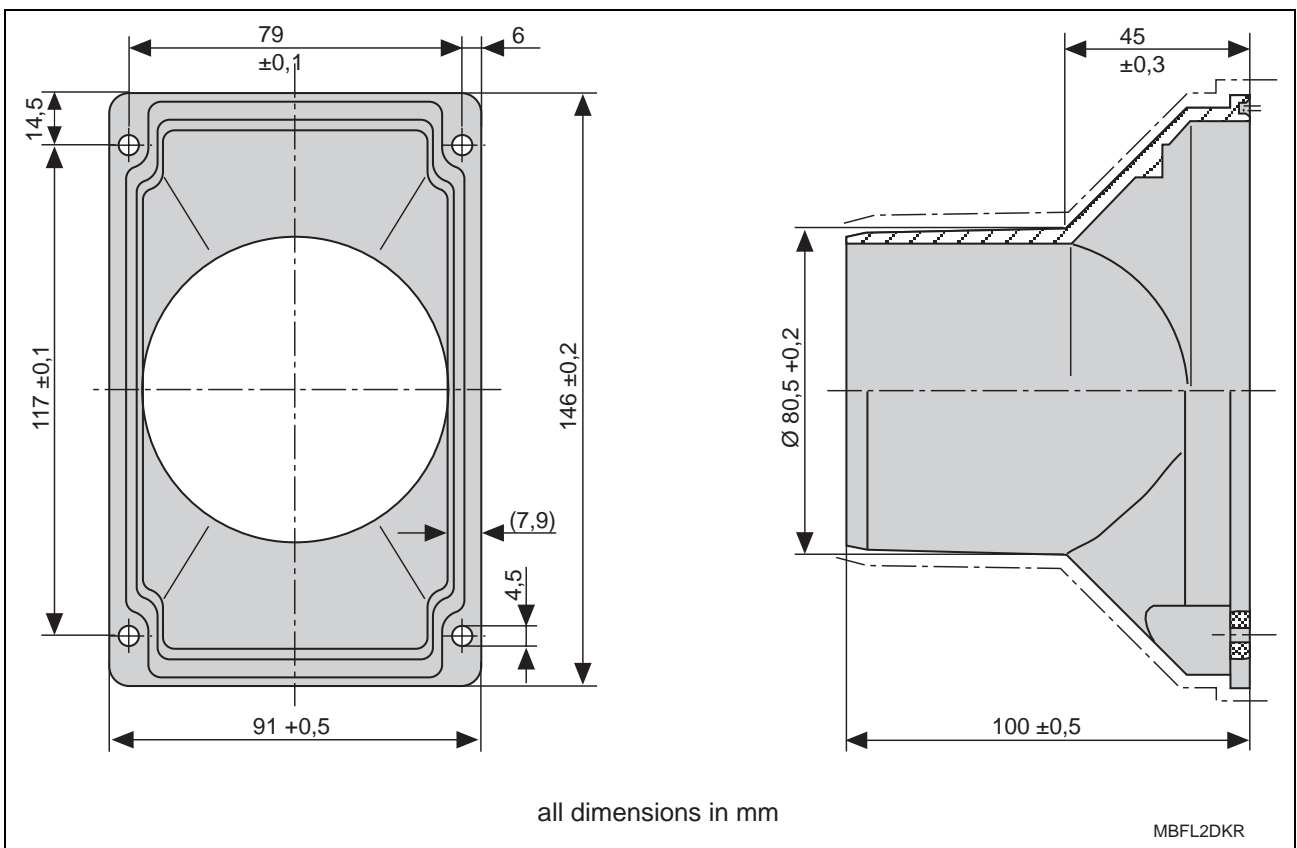

Fig. 5-19: Flange

5.5 Leads



Failure or malfunction caused by improperly installed leads!

⇒ Observe the following instructions.

CAUTION

Lead arrangement ⇒ Maintain a distance of at least 100 mm between power and control or signal cables, e. g.; feedback or NC connections

- or -

⇒ isolate the cable channel metallically (see illustration below).

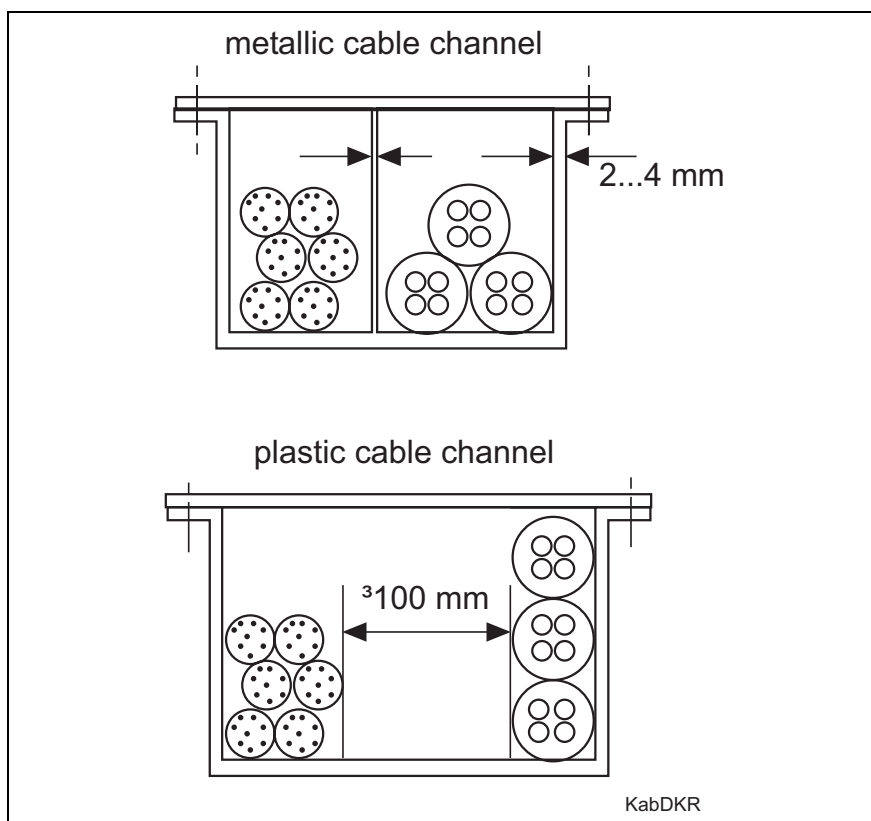

Fig. 5-20: Various cable channels

⇒ Control or signal cables, e.g., feedback connections, should not be routed near high-frequency equipment, magnetic fields, i.e., transformers or chokes and so on, or high-voltage leads.

- Length of the leads**
- Maximum length of the motor cable is 75 meters
 - Maximum length of the feedback connection is 75 meters
-



CAUTION

Failure or malfunction caused by clamping points or intermediate coupler units!

⇒ The maximum lengths do not apply to clamping points and intermediate coupler units. In addition, the following notes apply to the indicated lengths of the leads.

- Note:** The lengths given apply to
- direct connections between drive and motor (without clamping points or intermediate coupler units),
 - ready-made cables and
 - an ambient temperature of 40 °C (per EN 60 204).
-

- Note:** For further details on the current loads of leads as dependent upon ambient temperatures, please see Fig. 6-10.
-

5.6 Measures to avoid sources of interference in the control cabinet



CAUTION

Failure and malfunction caused by interference signals!

⇒ Observe the following instructions, in order to avoid electromagnetic or lead-related interference signals.

If inductive loads, e.g., chokes, contactors or relays, must be switched with the use of a contact or semi-conductor, then these must be shielded:

- ⇒ Use recovery diodes with direct current.
- ⇒ Use contactor-type related resistance-capacitance coupling with alternating current.
- ⇒ Attach shielding directly to the inductance. Not doing so could considerably reduce the shielding effects.
- ⇒ Do not use varistors as protective circuits.

If high-frequency equipment is used in the plant, e.g., components of anodizing equipment, then:

⇒ situate and wire such equipment outside of the cabinet.

To maintain the limit values for class B (interference suppression level N) as per DIN VDE 0470-1, edition dated 11.92 and table I as per DIN EN 55 014, edition dated 12.93, at the machine, in particular when operating such in light industrial or residential areas, then the following applies:

- Route the motor power cable separately
 - or -
 - use shielded motor power cable.
- Mount and operate a suitable interference suppression filter in the power supply lead of the machine or plant.

Note: For further details, please see the Project Planning Manual on "Electromagnetic Compatibility (EMC) of AC Drives".

6 Planning the electrical connections

6.1 Preliminary remark

Note: All interconnecting diagrams made available by Rexroth Indramat exclusively serve to prepare the circuit diagrams of the plant!

When wiring the plant, always use the circuit diagrams made available by the manufacturer of the machine!

6.2 Fundamental guidelines



Damage to persons or property caused by failure or malfunction owing to improper design and/or wiring!

WARNING ⇒ Observe the following instructions.

Connecting the grounded conductor

⇒ The grounded conductor of the motors must always be connected to the drive.

⇒ Always connect the drive to the grounded conductor system of the mains or the cabinet. Note the details on this in section 6.4.

Lead type

⇒ Twist the strands of motor power cables.

⇒ Analog signals must be conducted via shielded leads. The shields may only be connected to the drive. Avoid ground loops.

⇒ Mains or motor leads may not, at any point, be connected to the extra-low voltages DC ± 15 V and DC +24 V, nor should they come into contact with these.

Note: With regard to the assembly of the control cabinet and its wiring some additional rules have to be observed, in order to avoid sources of interference. For details about this subject see the project manual with the title "Electromagnetic Compatibility (EMC) in Drive and Control Systems".

6.3 Positions of the connectors, pin configurations and lead cross sections

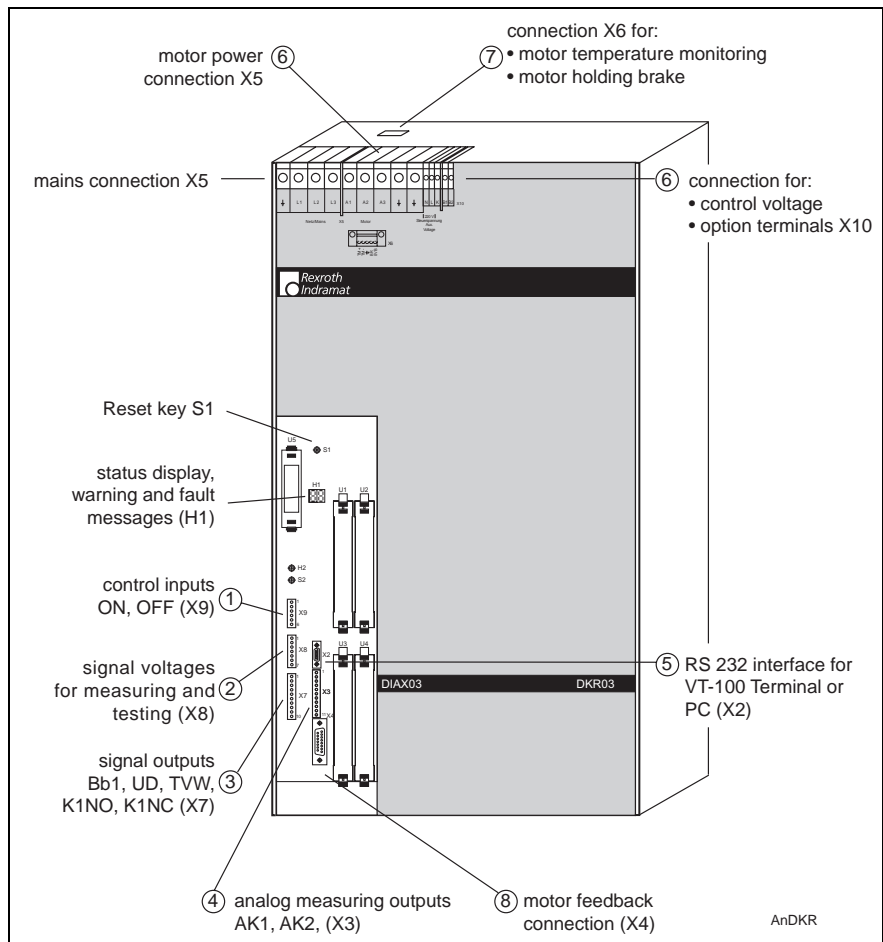

Fig. 6-1: Front of unit DKR02/DKR03 with connections labeled, names and explanations

Note: Except for terminal connectors X5, X6 and X10 the arrangement of the connections on DKR04 devices corresponds to the arrangement on DKR02/DKR03 devices. In case of DKR04 devices these terminal connectors are situated at the bottom side of the device.

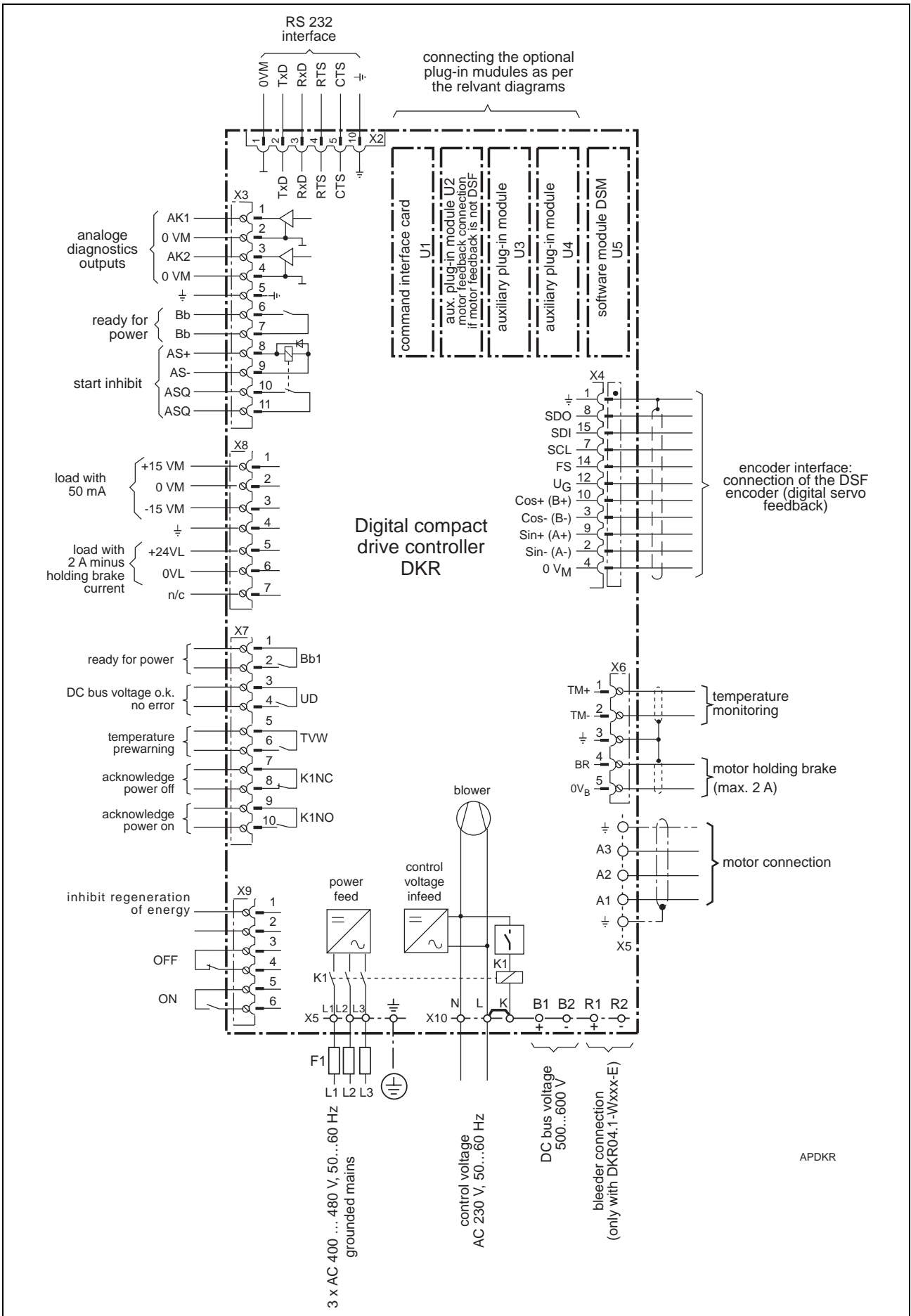

Fig. 6-2: Connection allocations

terminal connector designation	X2	X3	X4	X5	X6	X7	X8	X9	X10	X11
lead cross sections		1,5	*2	10...35 ^{*1}	2,5	2,5	2,5	2,5	10	

*1: finely stranded

*2: cable assembly made by Rexroth Indramat

Fig. 6-3: Lead cross sections [mm²]

6.4 Mains connection



CAUTION

Failure or malfunction caused by a FI current limiting type circuit breaker!

⇒ Do not mount FI current limiting type circuit breakers in the power supply lead to the drive.

Permissible rated voltage

The following applies to the mains input terminal connectors of the drive:

- X5/L1, L2, L3: 3xAC 400 ... 480 V, ±10 %; 50 ... 60 Hz, ±2 Hz
- X10/L, N: 1xAC 230 V, ±10 %; 50 ... 60 Hz; 200 VA (or. 300 VA)

Periodic overvoltage

The devices are type-tested according to EN61 800-3 (industrial area); i. e. the voltage peaks of the mains voltage must not exceed the following values:

- 1 kV phase/phase and
- 2 kV phase/earth

Grounded three-phase systems

Direct mains connection

The drive can be connected either to grounded star systems or external conductor three-phase systems directly.

If the mains voltage is not compatible with the permissible rated power voltage, then an autotransformer for matching the voltages must be implemented.

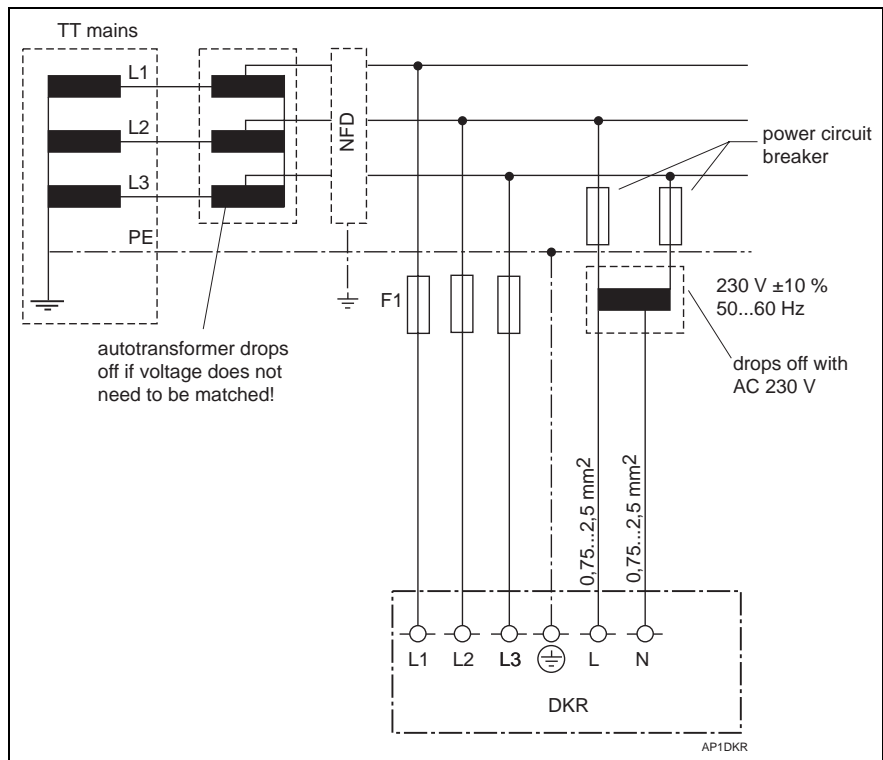

power circuit breaker: For primary protection of transformers with a high degree of inrush peak (e. g. Siemens, 3VU13 00-1TF00)

Fig. 6-4: Connection to a grounded three-phase system

Note: See chapter 6.5 for information on the lead cross sections, nominal currents of fuses and transformer (if necessary).

Ungrounded three-phase system



CAUTION

Damage to persons or property caused by overvoltage between phase conductor and housing!

⇒ Only connect the drive controller to ungrounded three-phase systems via an isolating transformer or protect the installation by means of overvoltage suppressors!

Protection with the use of an isolating transformer

The isolating transformer protects the drive controller reliably from dangerous overvoltage. If the mains voltage should additionally not be compatible with the rated power voltage of the controller, then the use of an isolating transformer to match the voltages is recommended.

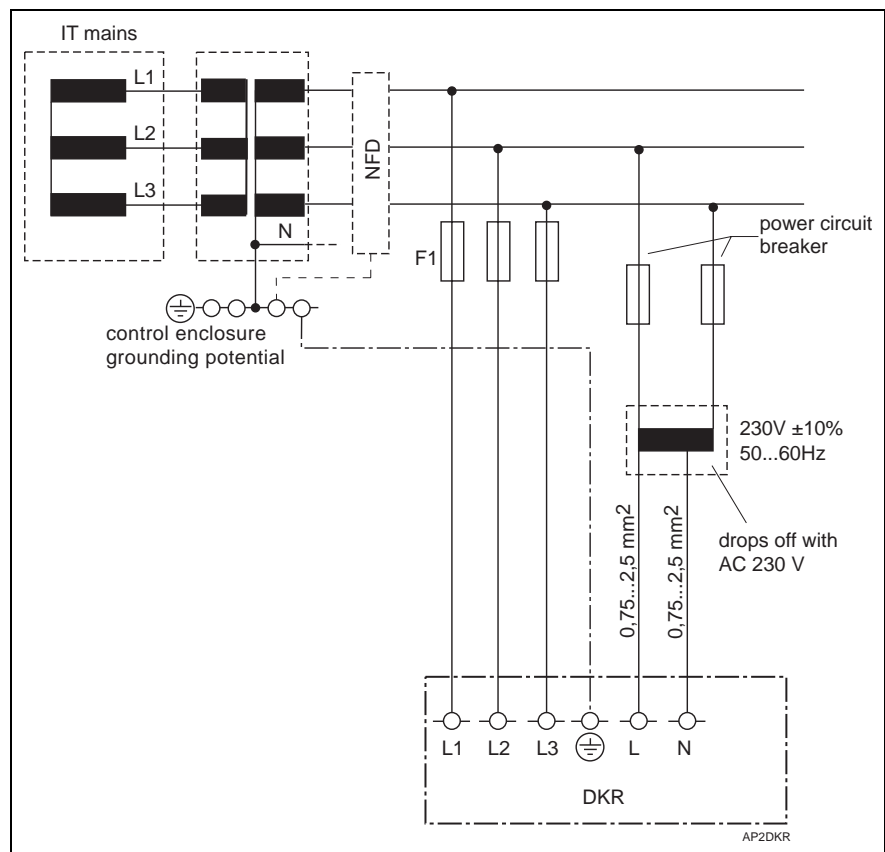

power circuit breaker: For primary protection of transformers with a high degree of inrush peak (e. g. Siemens, 3VU13 00-1TF00)

Fig. 6-5: Connection to an ungrounded three-phase system

Protection with the use of an overvoltage suppressor

The drive may only be operated with an ungrounded three-phase system - except when connected via an isolating transformer - if the machine is protected with the use of an overvoltage suppressor.

Note: The information on page 6-13 will help you select appropriate overvoltage suppressors.

Note: Operating the drive with an overvoltage suppressor does not offer the same level of protection as does the use of an isolating transformer. The purchase of big overvoltage suppressors is, however, much less expensive. Please note that an overvoltage suppressor, however, is destroyed once used and then must be replaced!

If the mains voltage is not compatible with the permissible rated power voltage, then an autotransformer can be used to match the voltages.

Note: The information in chapter 6-11 will help you dimension the autotransformer.

The following two figures show you

- the connection to ungrounded three-phase systems with overvoltage suppressor and
- two possibilities for triggering the separation of the drive from the network with this setup.

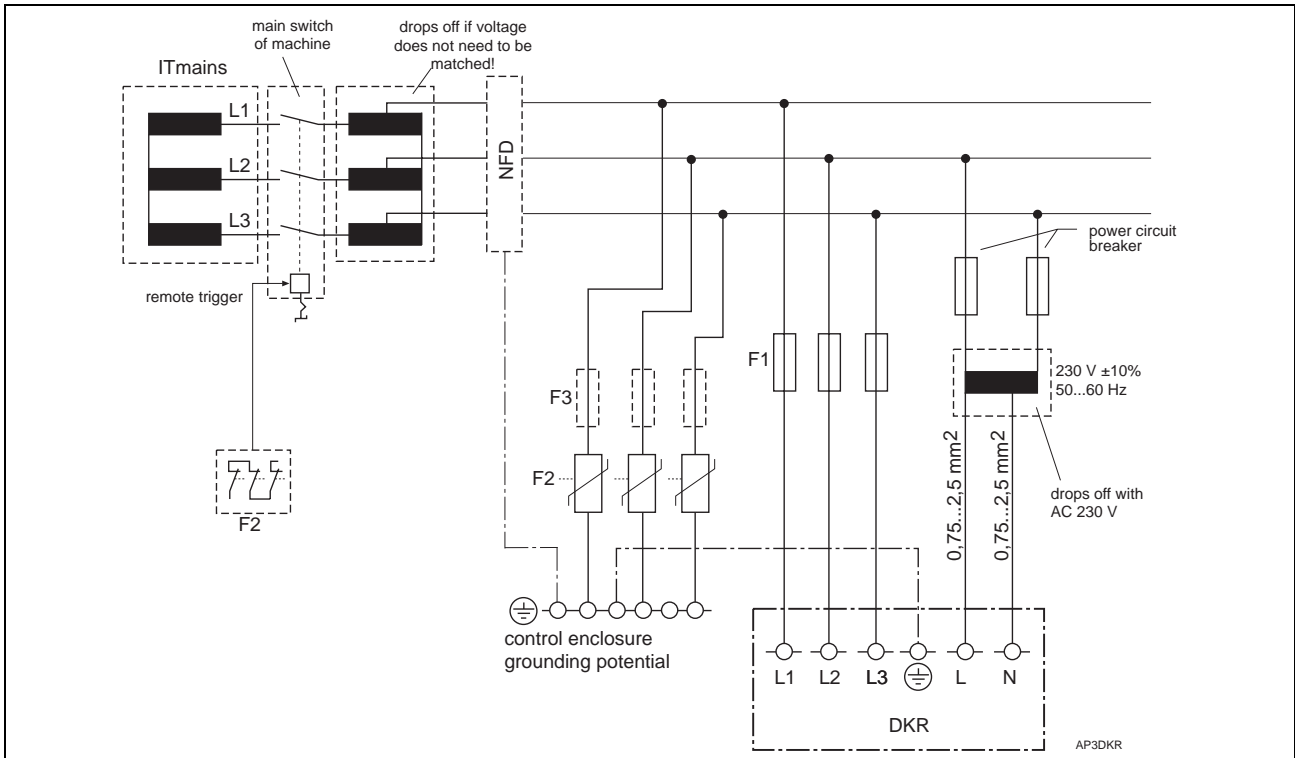

power circuit breaker: For primary protection of transformers with a high degree of inrush peak (e.g. Siemens, 3VU13 00-1TF0)

Fig. 6-6: Connection to an ungrounded three-phase system; activation of the overvoltage suppressors **triggers the main switch of the machine**

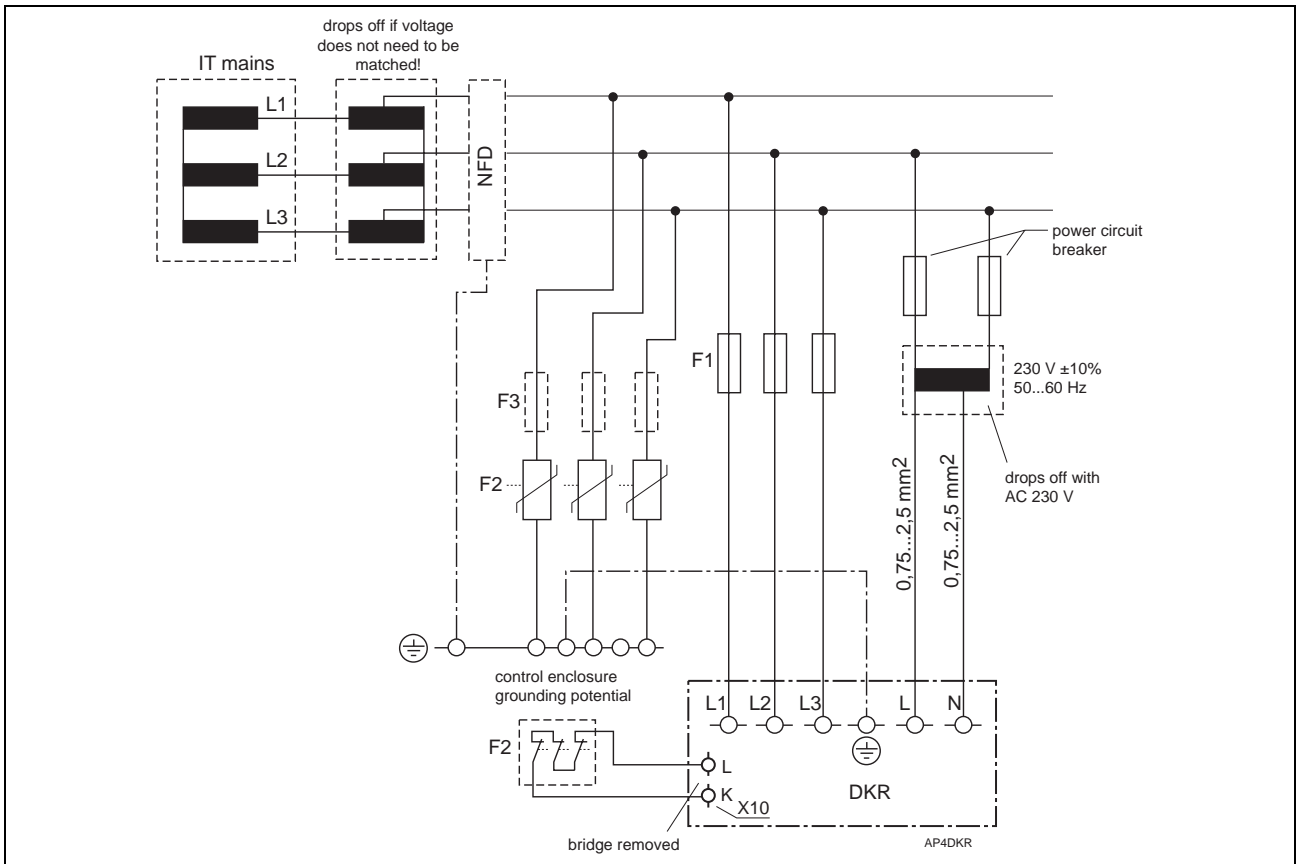

power circuit breaker: For primary protection of transformers with a high degree of inrush peak (e. g. Siemens, 3VU13 00-1TF00)

Fig. 6-7: Connection to an ungrounded three-phase system; activation of the overvoltage suppressors **causes the release of the system contactor in the drive controller**

6.5 Dimensioning

Mains fuses and lead cross sections

Mains fuses and the lead cross sections of the power connections are dependent upon the continuous power of the motor which has been mounted. They have to be dimensioned in accordance with the indications in the motor project planning manuals.



CAUTION

Failure or malfunction caused by mains connection values that fall below the minimum values!

⇒ The values mustn't ever fall below the data in the table below. Always dimension the mains connection at least in accordance with the power effectively required. When dimensioning the mains connection, allow for sufficient reserves!

Type of drive controller	Minimum mains fuse F1, type	Minimum lead cross section in mm ²
DKR03.1-100-...	3 x NH25gl	4
DKR03.1-200-...	3 x NH35gl	6
DKR02.1-200-...	3 x NH50gl	10
DKR02.1-300-...	3 x NH63gl	16
DKR04.1-300-...	3 x NH80gl	25
DKR04.1-400-...	3 x NH80gl	25

Fig. 6-8: Minimum data for mains fuses and lead cross sections

Calculate the lead cross sections required in terms of the actual motor power and the highest ambient temperatures. Follow the steps described below:

1. Determine the mains current I_{NetzDKR} using the formula:

$$I_{\text{NetzDKR}} = 1,8 * P_{\text{DauerMotor}}$$

I_{NetzDKR} : mains current [A]

$P_{\text{DauerMotor}}$: (effectively required) continuous output of the motor [kW]

Fig. 6-9: Formula to determine the mains power

Note: The mains power (I_{NetzDKR}) is also required in order to determine the mains filter NFD. With regard to the use and dimensions of the mains filter please see the documentation on "Electromagnetic Compatibility (EMC) in Drive and Control Systems".

The nominal current required is not dependent on the mains voltage. There is a thyristor bridge on the mains of the DKR which operates with phase control at a mains voltage of > 400 V. This keeps the DC bus voltage at approximately 520 V. With higher mains voltages the power factor, which is about 1 at 400 V, is reduced.

If the DKR must be connected via a transformer, then the secondary voltage should equal 400 V.

- Determine the conversion factor (as per EN 60 204-1/02.86). This factor can be read directly from the following table using the highest, i.e., the temperature at the machine.

Current load table		Conversion table for ambient temperatures above 30 °C	
rated cross section of the leads in m ²	Current load of leads on machines with normal applications in the channel "B2"	Ambient temperature in °C	Conversion factor for Rexroth Indramat cable
1	9.6	30	1.45
1.5	12.2	35	1.4
2.5	16.5	40	1.35
4	23	45	1.29
6	29	50	1.24
10	40	55	1.17
16	53	60	1.11
25	67		
35	83		
50 ¹⁾	98		

1): actual cross section equals 47 mm²

Fig. 6-10: Conversion factor and current load table for ambient temperatures greater than 30 °C (as per EN 60 204-1/02.86)

Note: The dimensions of the cross sections of cable assembly made by Rexroth Indramat meet the requirements set in EN 60 204-1/02.86. For details on motor power cables, please see the relevant motor documentation.

Autotransformers



Damage to the autotransformer if it is not sized large enough!

⇒ Please note the following guidelines.

CAUTION

⇒ Dimension the power S_{Netz} of a possibly required autotransformer in terms of the rated motor power or at least, however, in terms of the actual continuous motor power:

$$I_{\text{NetzDKR}} = 1,8 * P_{\text{DauerMotor}}$$

$$S_{\text{Netz}} = \sqrt{3} * U_{\text{NetzDKR}} * I_{\text{NetzDKR}}$$

I_{NetzDKR} : mains current [A]
 $P_{\text{DauerMotor}}$: actual continuous power of the motor [kW]
 S_{Netz} : power of the autotransformer [kVA]
 U_{NetzDKR} : mains voltage [V]

Fig. 6-11: Formula to determine the power of the autotransformer

⇒ Make sure that the inductive components of the relative short-circuit voltage u_{KX} are less than 4 %:

$$u_{\text{KX}} = \frac{u_{\text{KX1}}}{U_{\text{Nenn1}}} * 100\%$$

u_{KX1} : primary short-circuit voltage (inductive components) [V]
 U_{Nenn1} : rated voltage of the transformer, input side [V]

Fig. 6-12: Formula to determine the inductive components of the primary mains voltage

Isolating transformers



Damage to the isolating transformer if it is not sized large enough!

⇒ Please note the following guidelines.

CAUTION

⇒ Dimension the power S_{Netz} of a possibly isolating transformer in terms of the rated motor power or at least, however, in terms of the actual continuous motor power (calculation: see Fig. 6-11).

⇒ Make sure that the power of the isolating transformer, as dependent upon the drive, does not drop below the values listed in the following table.:

Type of drive controller	Minimum power of the isolating transformer (S_{Netz}) [kVA]
DKR03.1-100-...	25
DKR03.1-200-...	40
DKR02.1-200-...	50
DKR02.1-300-...	65
DKR04.1-300-...	80
DKR04.1-400-...	100

Fig. 6-13: Minimum power of the isolating transformer depending on the drive controller in use

⇒ Make sure that the inductive components of the relative short-circuit voltage u_{KX} are less than 4 % (calculation: see Fig. 6-12).

Overvoltage suppressor

The drive may only be operated with ungrounded three-phase systems -- in addition to an isolating transformer -- if the machine or plant is protected by overvoltage suppressors.

The recommended overvoltage suppressors protect up to leakage currents equal to $I^2t = 750 \text{ A}^2\text{s}$ (30 s with 5 A).

For thermal reasons, higher leakage currents trigger the signal contact. The overvoltage suppressors are, as a result, defective and must then be replaced.

Type of drive controller	Fuse F3, Type	Overvoltage suppressor F2, Type
DKR03.1-100-...	-	e. g. DEHNgard®, manufactured by DEHN + SÖHNE D-92306 Neumarkt Tel: +49 (0)9181/906-0
DKR03.1-200-...	-	
DKR02.1-200-...	-	
DKR02.1-300-...	3 · 100Agl	-
DKR04.1-300-...		-
DKR04.1-400-...		-

Fig. 6-14: Types of fuses and overvoltage suppressors

6.6 Functions and allocations of individual interfaces

X2: Serial interface

The serial interface serves for the communication between the drive controller and a PC. It is needed for programming, parameterization and diagnosis during commissioning and service. For this purpose the appropriate software (e. g. SERCTOP or DriveTop) needs to be installed on the PC.

It can be operated as RS-232 or, from device index A12 onwards, as RS-485.

Note: For details on how to install interface leads please see the documentation on "Electromagnetic Compatibility (EMC) in Drive and Control Systems".

RS-232 interface

The RS-232 interface enables:

- a maximum number of participants of 1, i. e. , when using DriveTop, only one drive can be parameterized via the RS-232 interface,
- a transmission length of up to 15 meters and
- transmission rates of 9600/19200 baud.

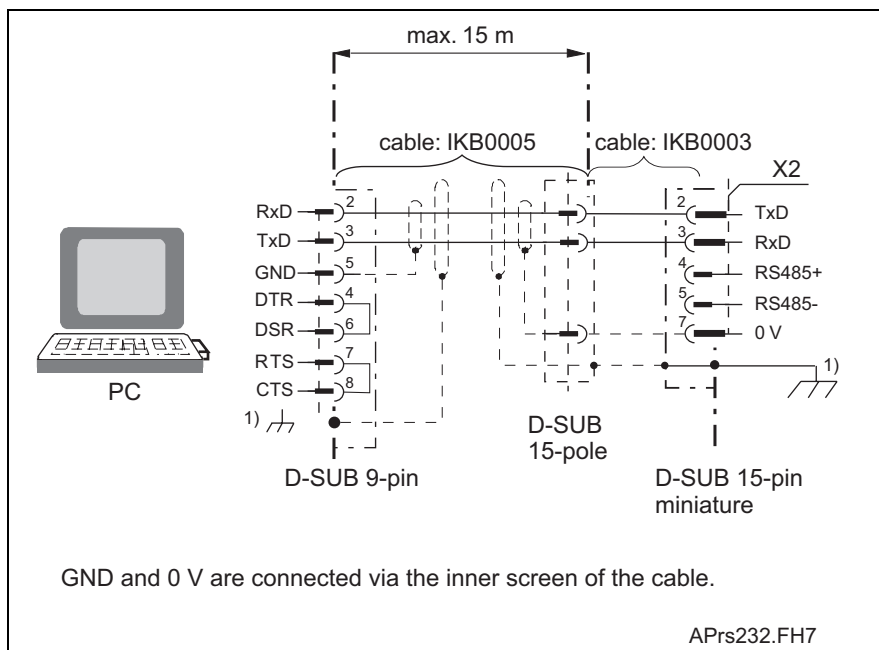

1): Connector outer screen to ground potential (strain relief of metallic connector case) on PC side and on device.

Fig. 6-15: Connecting a PC using the RS-232 interface

RS-485 interface

The RS-485 interface enables:

- the implementation of a serial bus with up to 31 participants connected via a two-wire line (half duplex mode), i. e., it can be used to start up several DKCs with DriveTop without having to plug into a different socket of the interface cable,
- a transmission length of up to 500 meters,
- transmission rates of 9600/19200 baud and
- the implementation of central PC-supported visualization unit.

As a matter of principle, there are two solutions for operation with RS-485:

- RS-232/RS-485 converter between PC and drives or
- RS-485 plug-in card in PC.

Note: Please contact your PC supplier to find the solution for your application.

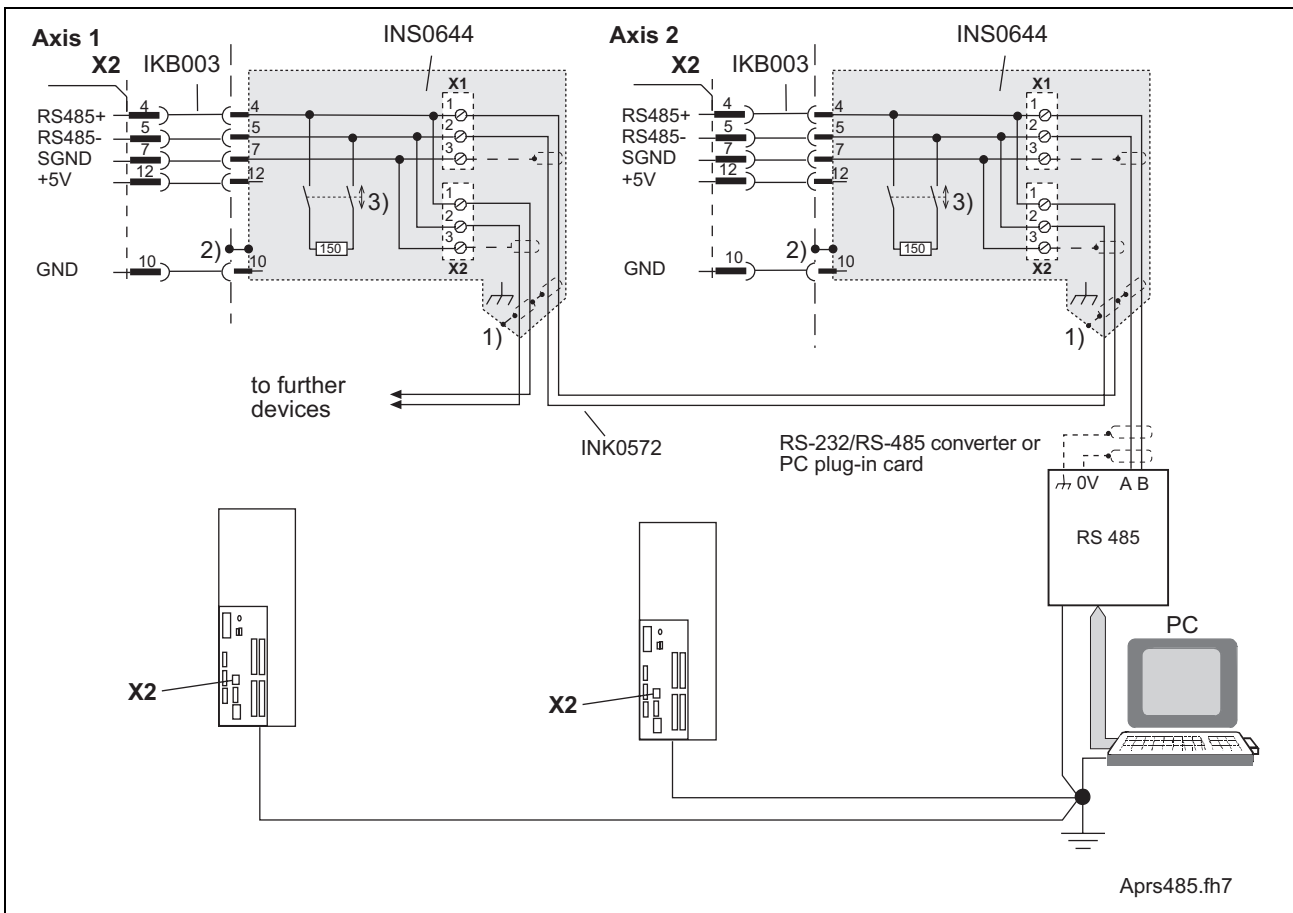

- 1): Connector outer screen to ground potential (strain relief of metallic connector case) on PC side and on device.
- 2): Connection of device ground with the connector case with the fixation screws of the connector.
- 3): If the drive controller is fitted as the geometrically last participant of a RS485 bus, activate the bus termination.

Fig. 6-16: Example on how to connect an RS-485 interface

X3: Analog output and signal contact

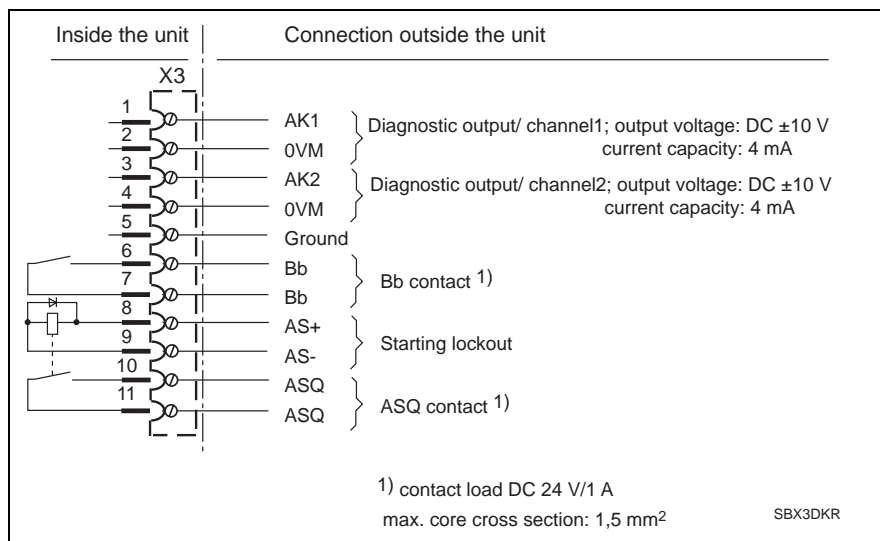

Fig. 6-17: Connector assignment at X3

Analog diagnostics outputs (AK1 and AK2)

The analog diagnostic outputs can serve for the output of different drive-controlled values. For details see documentation "DIAX03 – Functional Description".

Output voltage range: DC ± 10 V

Current load: 4 mA

Ready for power ON (Bb contact)

The Bb contact is closed if all equipment-internal monitoring functions are signaling that they are in proper working order.

The drive is then ready for power ON.

In the event of a malfunction, the contact opens and the internal power contactor drops off if P-0-0118=1 is set.



CAUTION

Damage to property caused by uncontrolled coasting of the motor after release of the Bb contact!

⇒ In case the coasting of the motor after release of the Bb contact causes problems for your application, use a brake resistor or a service brake.



CAUTION

Malfunction of the installation owing to damaged Bb1 contact!

⇒ Observe the following instructions, in order to avoid damage to the Bb1 contact and malfunction of the installation.

⇒ Do not overload the contact. For loads see Fig. 6-17.

⇒ Do not connect the contactor coils directly to the contact because of high short-term currents!

⇒ Do not use varistors to protect the contacts.

**Starting lockout
(inputs AS+, AS-)**

By means of the inputs AS+ and AS- you can avoid unintended starting of the motor in case of failure.

Note: With this function it is impossible to stop axes which are moving!

**Check back signal
of the starting lockout
(ASQ-Contact)**

The function "starting lockout" is activated by applying DC 20 ... 30 V between terminal connectors AS+ and AS-. The power of the voltage source needs to be 1,5 W.

This contact closes once the function "starting lockout" is activated. Use the ASQ contact as a check back signal for switching the internal starting Contact load: DC 24 V, 1 A

X4: Motor feedback

To connect the motor feedback please consider the following aspects:

- Use feedback cable assembly manufactured by Rexroth Indramat.
- Note the maximum cable length of 75 meters (Rexroth Indramat cable).
- Operate only those motor/drive combinations which have been documented in the configuration sheets.

**CAUTION****Malfunction of the drive and unpredictable risks caused by incorrectly connected feedback leads!**

- ⇒ Please make sure that the feedback connection is correctly wired (guaranteed for ready-made Rexroth Indramat feedback cables).
- ⇒ Connect only those motors with DSF or GDS feedback to X4.
- ⇒ The feedback leads of motors with gear wheel encoders must be connected to the DZF auxiliary plug-in module.

X6: Monitoring motor temperature and holding brakes

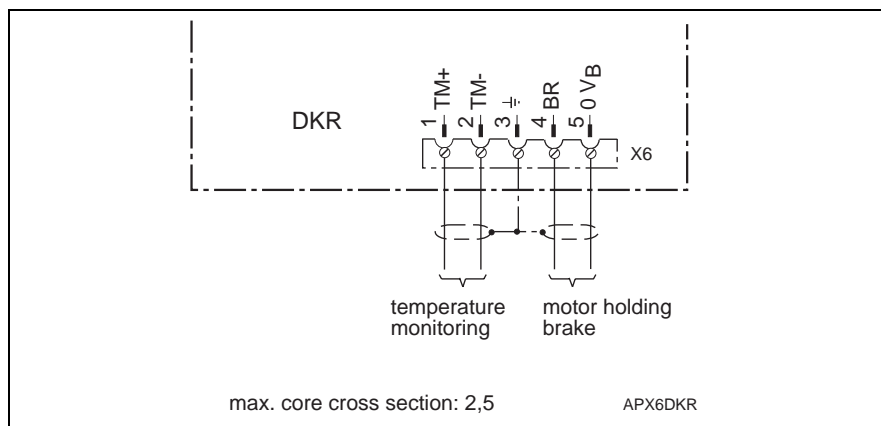

Fig. 6-18: Connector assignment at X6

Both motor temperature and holding brake are monitored and controlled by the drive controller. There are two possibilities to connect the lead to terminal connector X6:

- Use a motor power cable assembly manufactured by Rexroth Indramat (recommended) or
- Use two shielded lead pairs (motor temperature monitoring will not function without a shield!).

Note: Shielded leads are already integrated into Rexroth Indramat cables for the motor temperature monitoring and the holding brake devices. For detailed information, see the relevant motor documentation.

Maximum cable length: 75 meters (Rexroth Indramat cable).



Dangerous movements! Danger to persons caused by falling or descending axes!

- ⇒ The standard equipment motor brake or an external brake controlled directly by the servo drive are not sufficient to guarantee the safety of personnel!
- ⇒ Make sure to protect the personnel by means of primordial, safe measures:
 - Secure the danger zone by means of a protective fence or grid.
 - Secure vertical axes against falling or slipping after switching off the motor power by, for example:
 - mechanically securing the vertical axes,
 - adding an external brake / clamping mechanism or
 - balancing and thus compensating for the vertical axes mass and the gravitational force.

**CAUTION**

Possible malfunction caused by inappropriate holding brake!

- ⇒ Maximum permissible braking current: 2 A. Note that the maximum braking current can effect the voltage output "DC +24 V" at X8 (see page 6-20).
- ⇒ Do not overload the connection.
- ⇒ Use only closed-circuit brakes!

X7: Signal outputs

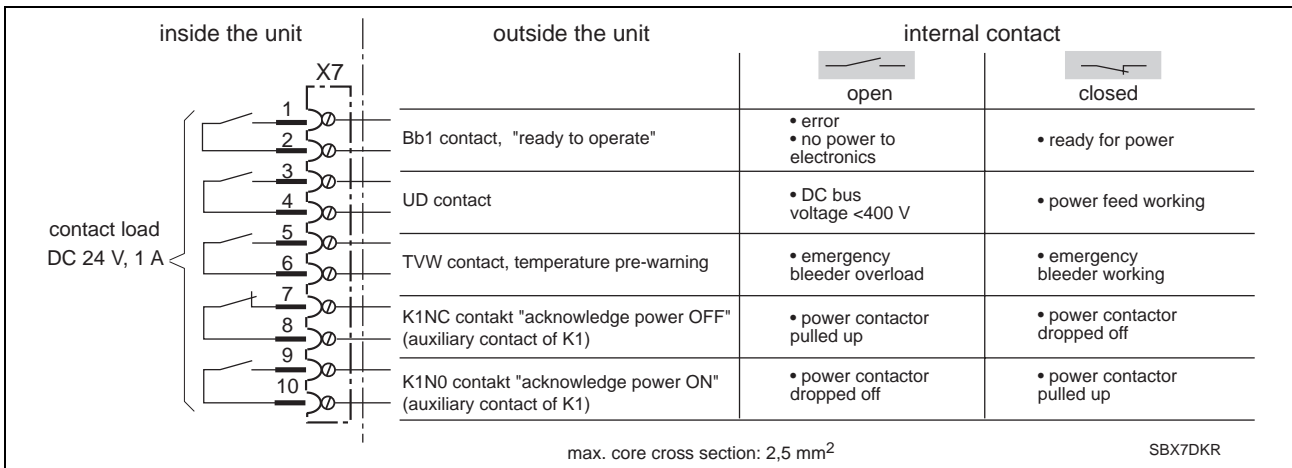

Fig. 6-19: Signal outputs at X7

**CAUTION**

Malfunction of the installation caused by damaged signal contacts!

- ⇒ Observe the following instructions, in order to avoid damage to the signal contacts and malfunction of the installation.

- ⇒ Do not overload the contact (see Fig. 6-19).
- ⇒ Do not connect the contactor coils directly to the contacts because of high short-term currents.
- ⇒ Do not use varistors to protect the signal contacts.

Ready for power (Bb1 contact)

The Bb1 contact is closed if:

- voltage was applied at any time at X5/L1, X5/L2, X5/L3 after switching on the control voltage and
- all equipment-internal monitoring functions are signaling that they are in working order.

The drive is then ready for input power (main contactor ON).

The contact opens:

- in the event of fault.
- after switching power off, unless the DC bus voltage has dropped below 250 V.

Temperature pre-warning (TVW contact)	The TVW contact opens with an overload of the internal optional emergency brake resistor [or the external brake resistor (only DKR4.1)].
Acknowledge power OFF (K1NC contact)	The K1NC contact is closed if the internal mains contactor has dropped off. This contact can be used as a precondition for the release of the door locking device.
Acknowledge power ON (K1NO contact)	The K1NO contact is closed if the internal mains contact is on. This contact can be used as a precondition for the release of the drive enable signal.
UD contact)	The UD contact acknowledges that the power supply system of the DKR is working properly. It opens in the event of the following disturbances: <ul style="list-style-type: none"> • DC bus voltage < 400 V • power contactor is open Can be used: <ul style="list-style-type: none"> • as a precondition for the feed release and • for diagnoses

X8: Signal voltages

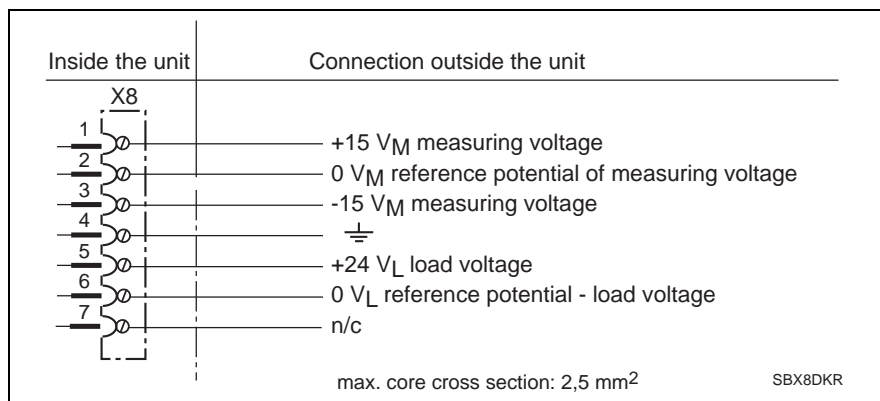

Fig. 6-20: Signal voltages at X8



CAUTION

Malfunction of the drive caused by coupling of interference voltage!

⇒ If you pick off voltages at terminal connector X8, use short, shielded leads and do not overload the outputs.

DC ±15 V	Voltage for measuring and testing purposes. These outputs are short-circuit proof. Maximum load: 50 mA.
DC +24 V	Voltage for measuring and testing purposes. These outputs are short-circuit proof. Maximum load: 2 A minus the holding brake current (holding brake: see also "X6: Monitoring motor temperature and holding brakes").

X9: Control inputs for internal power contactors

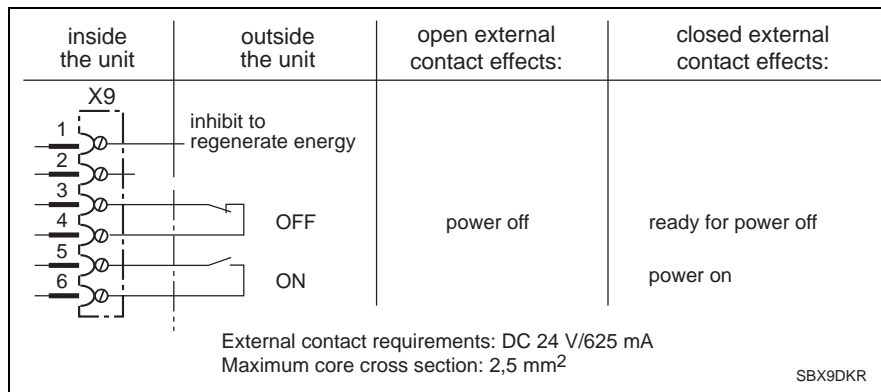

Fig. 6-21: Inputs at X9

Inhibit to regenerate energy

Only use input X9.1 in exceptional cases. Please contact us for a detailed description of how to use this input.

OFF contact

The internal power contactor can only be switched when this input is closed (see ON contact).

Opening the OFF contact immediately switches the internal power contactor off.

Note:

The power contactor has not been designed to switch **always** under load, i. e. it is only appropriate for de-energization and occasional E-stop. Use the "E-stop" function for emergency switch-off (see DIAX03 Function Description for details).

ON contact

When the ON contact is activated, the internal power contactor is switched on, if

- the OFF contact is closed and
- a machine-internal ready state is being signaled (see Bb1 contact also).

The internal power contactor is a self-holding contact.

X5 and X10: Power voltage, control voltage and brake resistor connections

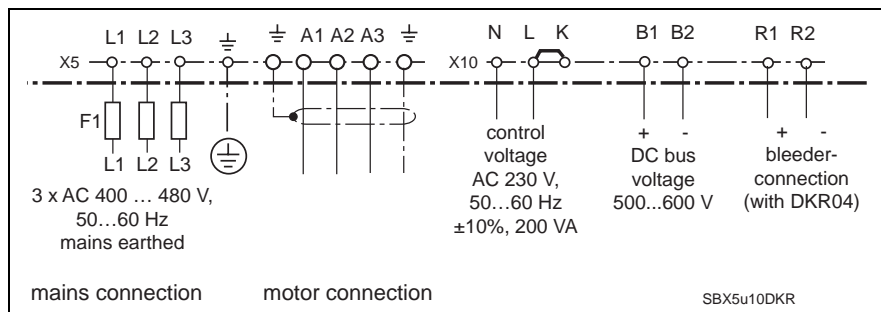

Fig. 6-22: Terminal connector assignments at X5 and X10

Terminal connector X10/K

If the internal main contactor K1 to increase safety is switched off directly, in other words, not via the attached auxiliary relays, then the contactor coil may also be directly isolated from the mains. This means that the bridge between X10/L and X10/K must be removed and the contactor coil K must be externally connected to L via a switch.

**Brake resistor connection
X10/R1 and X10/R2**

Note: Only DKR04.1 devices have terminal connectors for the brake resistor connection (DZB01.1).

DZB01.1 is the brake resistor for DKR04.1. The electronic system required to run the DZB01.1 has only been integrated in the "E version" (DKR04.1-WxxxE). "E devices" cannot be operated without DZB01.1. If you try to operate an "E device" without DZB01.1, the controller stops with the error message "F820 Braking resistor overload".

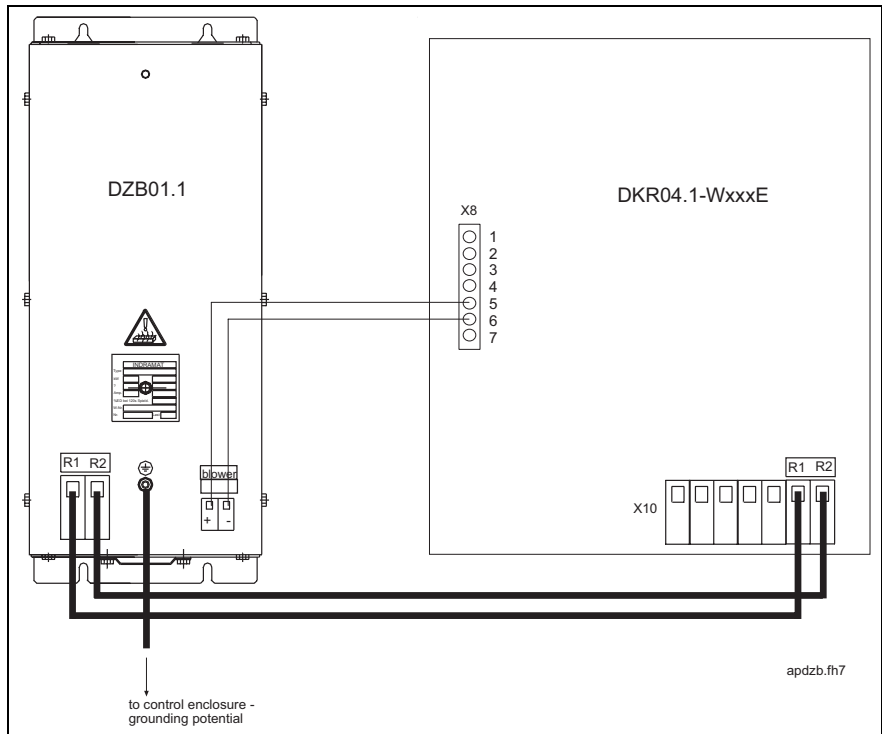

Fig. 6-23: Connection diagram DZB01.1 ↔ DKR04.1 (strongly simplified illustration)

7 Accessories

7.1 Connector kits

The following is required to connect the drive:

- connector kit S1-DKS 1 (for the connections on the basic unit without feedback connector) and
- connector kit S..-DDS 2 (for the connections of all the plug-in modules inserted in the basic unit including the feedback connector).

Connector kit for the basic unit

Connector kit S1-DKS 1 is always required. The connectors as depicted in the illustration below are part of this connector kit.

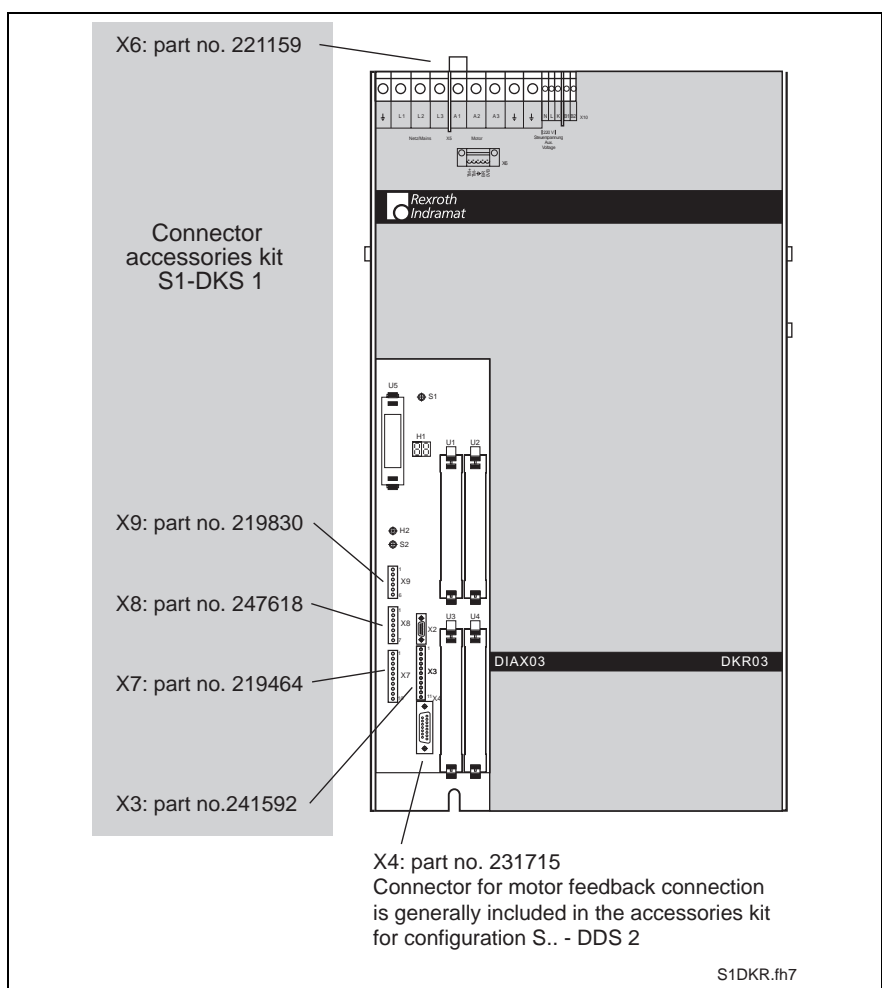

Fig. 7-1: The parts of connector kit S1-DKS 1

Connector kit for all plug-in modules of a configuration including the feedback connections

Which S..-DDS 2 connector set is required depends on the configuration of the drive. In addition to the connectors for all the plug-in modules, the feedback to drive connector is also included herein.

Due to the wide variety of possible combinations as well as the topicality connector kits are not listed in this documentation. For assistance in determining the correct connector set for a specific application, please consult your Rexroth Indramat Sales Representative.

Note: In the event that ready-made cables are to be used, then some of the connectors of the S..-DDS 2 kit may be superfluous. Rexroth Indramat, therefore, offers the connectors individually. Please see the documentation "DIAX03 plug-in modules for digital intelligent drive controllers" or the respective motor project planning manual.

7.2 Fiber optic cables

Drives equipped with SERCOS interface are connected to higher-ranking control units with the use of fiber optic cables.

It is necessary, however, to order these fiber optic cables (cable, connector or a cable assembly) separately.

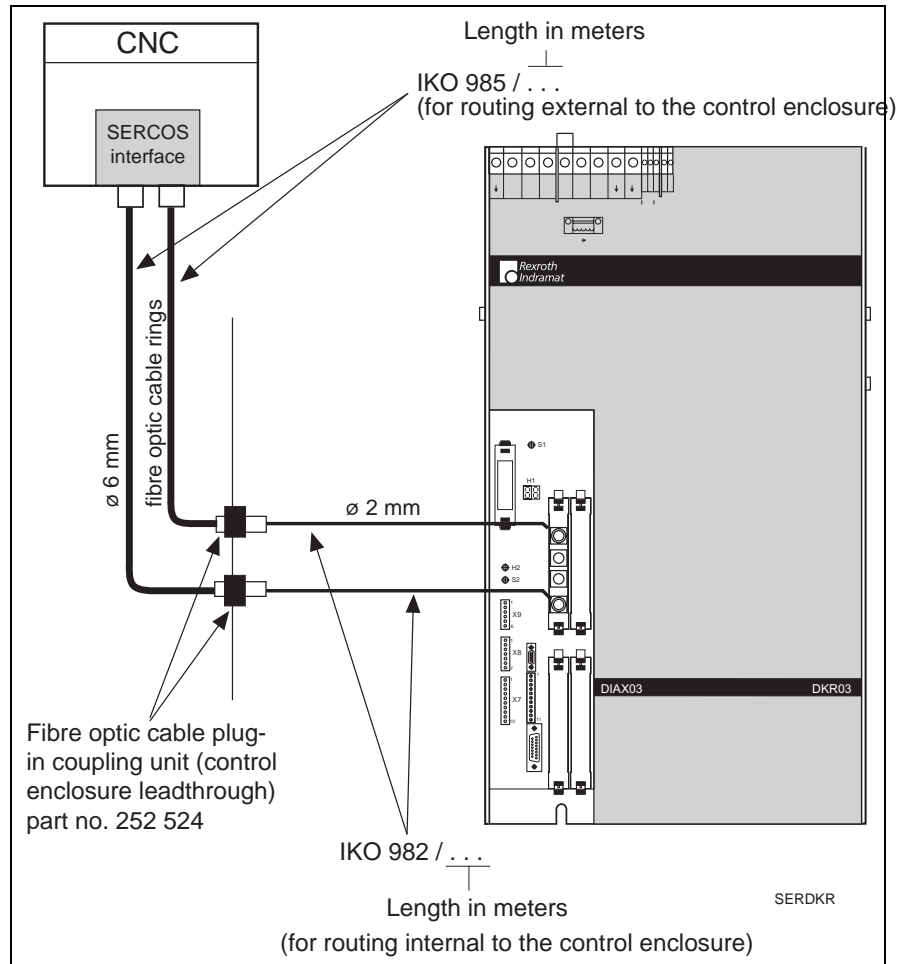

Fig. 7-2: Selecting the fiber optic cable assembly

Note: For more detailed information on fiber optic cables, please see the application manual "LWL - Handling".

7.3 Mechanical accessories

Accessories for duct cooling

The accessories required with duct cooling depend upon the drive.

The accessories needed for DKR02 and DKR03 drives are contained in the accessory kit "M1-RAC3".

The conversion accessories for the DKR04 drive are in the accessory kit "M2-RAC2".

The ducts must be ordered separately (see chapter 5.4, Fig. 5-16 and Fig. 5-17).

Mounting frames

In order to stabilize thin mounting panels or rear walls of the control cabinets, a mounting frame is used for DKR04, if the cooling method implements outside air. The mounting frame makes the control cabinet firm (see page 5-14).

8 Transport and storage

8.1 Transport



CAUTION

Damage to property caused by inappropriate transport!

- ⇒ Use a suitable mode of transportation.
 - ⇒ Use shock-damped supports if excessive shocks could occur during transport.
 - ⇒ Transport those components that could be damaged by any electrostatic loads, plug-in modules for example, in packaging that is capable of conducting such loads.
-

8.2 Storage



CAUTION

Damage to property caused by inappropriate storage!

- ⇒ When choosing the place of storage, observe the admissible range of temperature for storing the devices / plug-in modules: -30 °C to +85 °C.
 - ⇒ Store devices / plug-in modules dry, dust and shock free.
 - ⇒ Store those components that could be damaged by any electrostatic loads, plug-in modules for example, in packaging that is capable of conducting such loads.
-

Notes

9 Identifying the merchandise

9.1 General

The drive is packaged in a carton with all its accessories at the time of delivery. An envelope is attached to this carton. This envelope contains one copy of the delivery slip. If additional delivery documents are needed, then these must be requested.

The delivery could be distributed over several cartons if the order is larger. This will be noted on the delivery slip or freight documentation.

9.2 Delivery slip and barcode sticker

The delivery slip lists the merchandise of the entire delivery in terms of the names of the item and the order designations.

There is a barcode sticker on the packaging of the drive itself. It identifies the drive and the consignment.

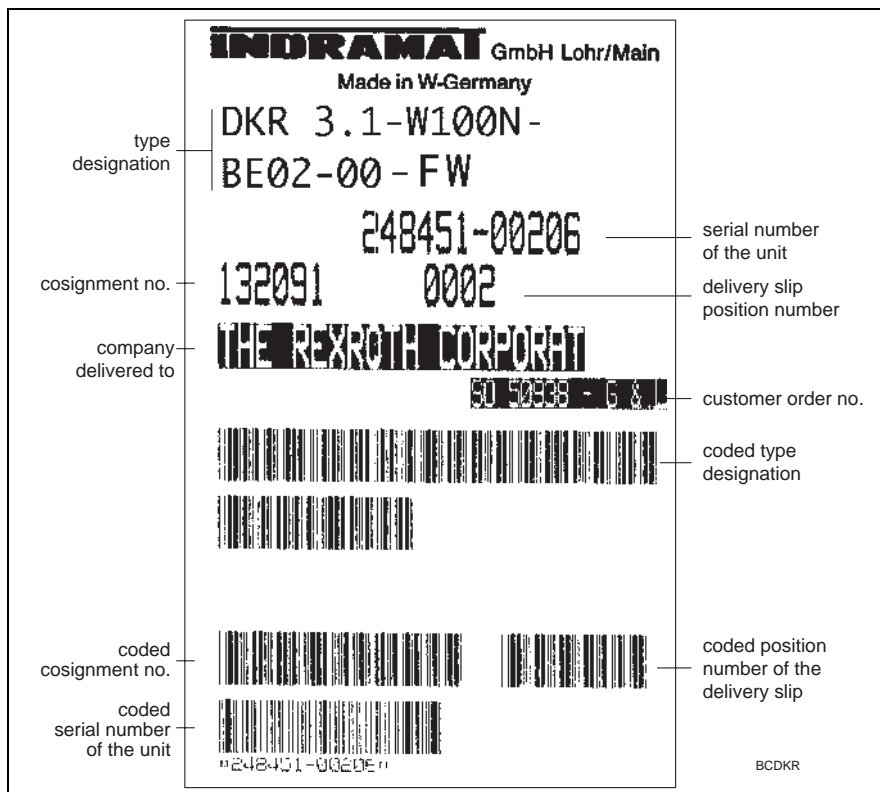

Fig. 9-1: Barcode sticker on the packaging of a DKR

9.3 Rating plate and type code of the drive controller

There are two rating/name plates on the drive for clear identification:

- rating plate bottom left. It serves to identify the basic unit.
- rating plate on the front side. It serves to
 - identify the basic unit,
 - identify the components/configuration (plug-in modules installed),
 - procure spare parts in case of malfunction and
 - provide service information.

In addition, there is a rating plate on the drive controller that helps you identify the software stored in the software module.

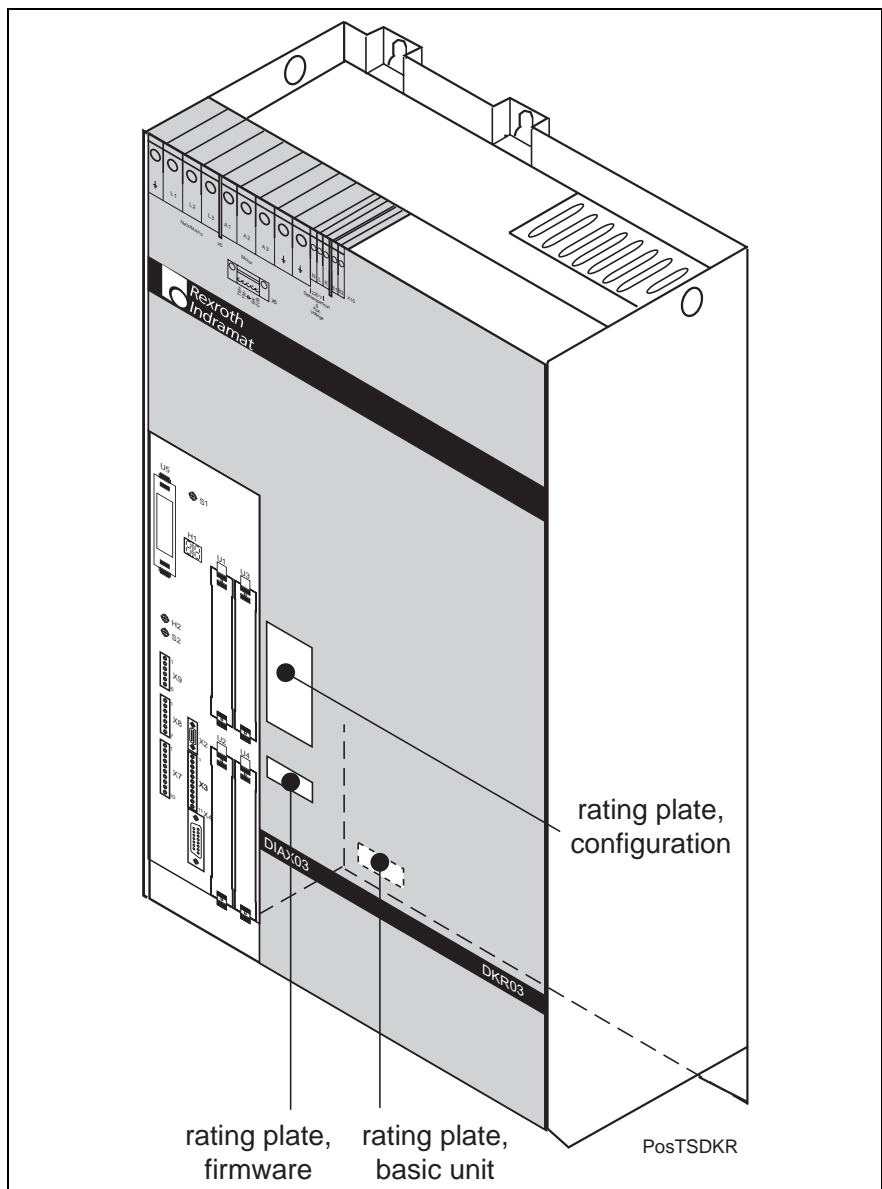

Fig. 9-2: Positions of the rating plates (DKR02/DKR03)

Note: Compare all the information on the rating plate with what is actually assembled into the drive.

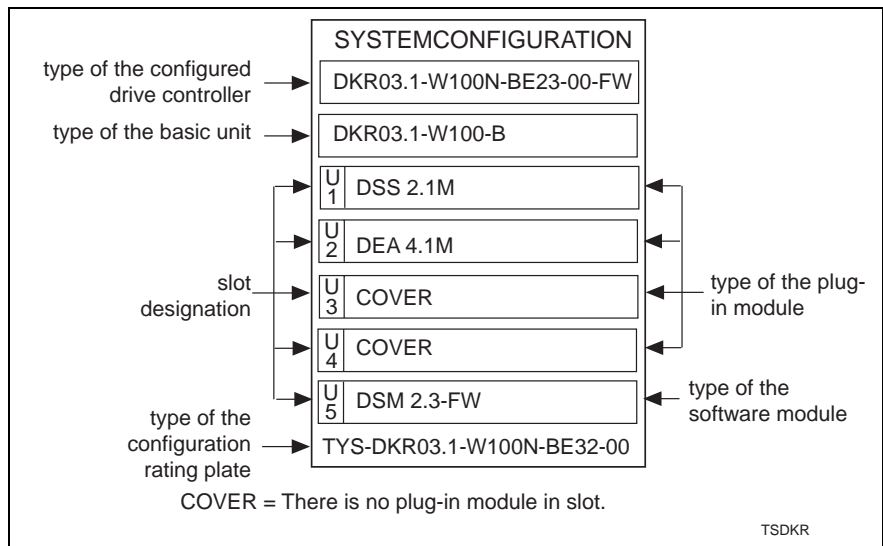

Fig. 9-3: Example: Configuration plate DKR

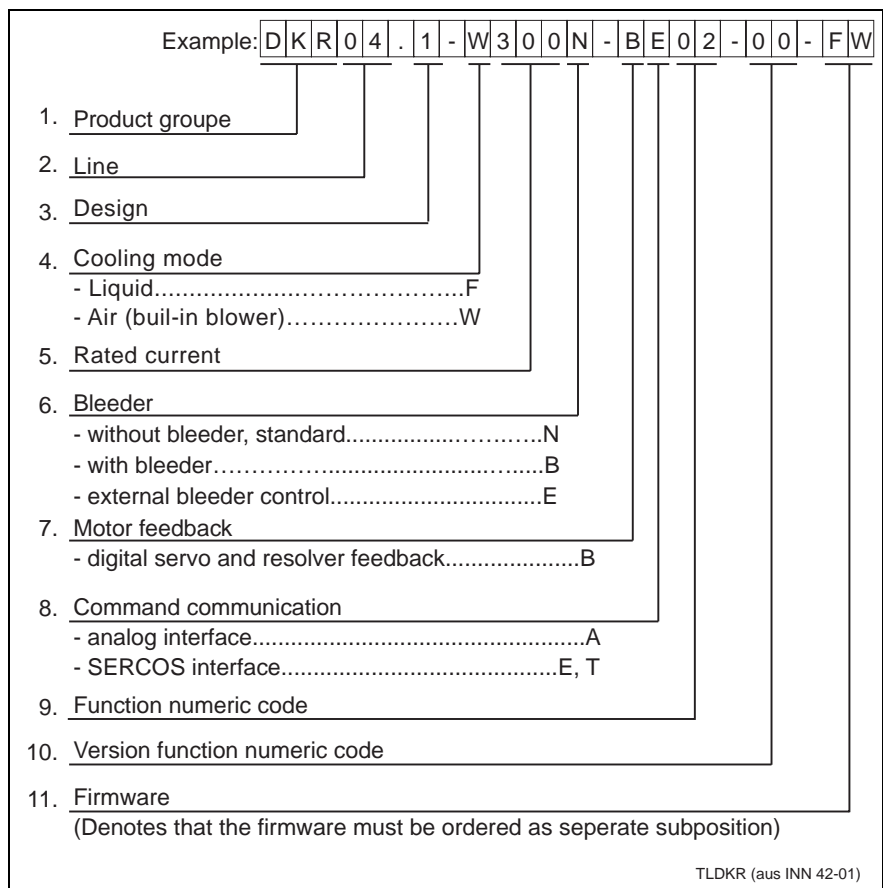

Fig. 9-4: Type code DKR

9.4 Type code of the auxiliary bleeders

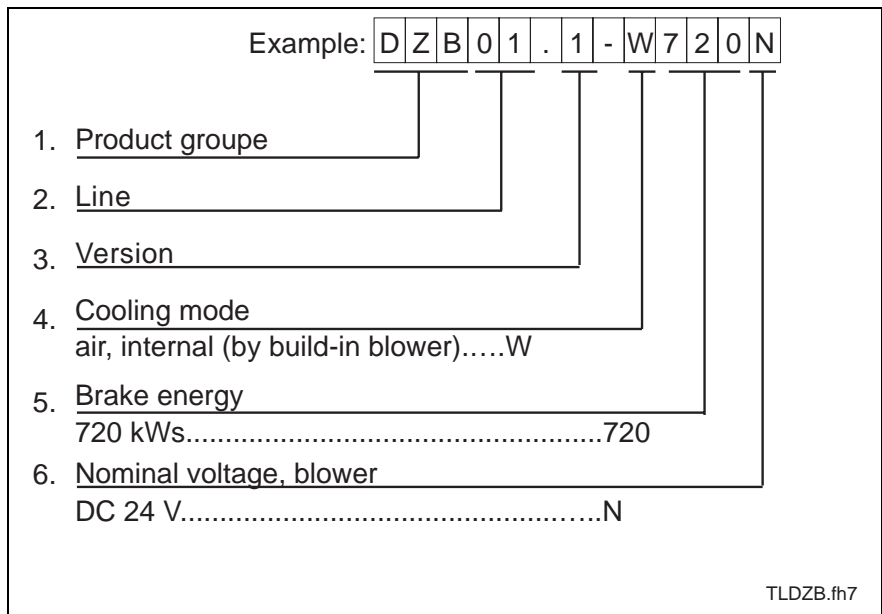

Fig. 9-5: Type code DZB

10 Mounting and installation

10.1 Adapting the cooling method

DKR02 and DKR03

Drive controllers of type DKR02 and DKR03 are supplied for "Cooling with air from inside the cabinet". If a different cooling method is required, then the drive must be converted **before** it is mounted into the cabinet.

Conversion to cooling method using air outside of cabinet

Conversion criteria

It is necessary to convert the cooling method, if

- there are two rectangular vents near the controller heatsink in the mounting panel of the control cabinet
- the air openings on the top and bottom side of the device to be replaced are closed with covers (which shows that the device was being operated with air from outside the cabinet).

Note: As a matter of principle observe the specifications of the machine manufacturer or control cabinet maker!

The parts required for the conversion to "Cooling with air from outside the cabinet" can be found in a plastic bag which is attached to the drive controller.

The plastic bag contains the following parts:

- cover 1
- cover 2
- gasket for cover 1
- gasket for cover 2
- 8 screws M4x12
- 8 gaskets for the screws M4

For the conversion please proceed according to the following figure.

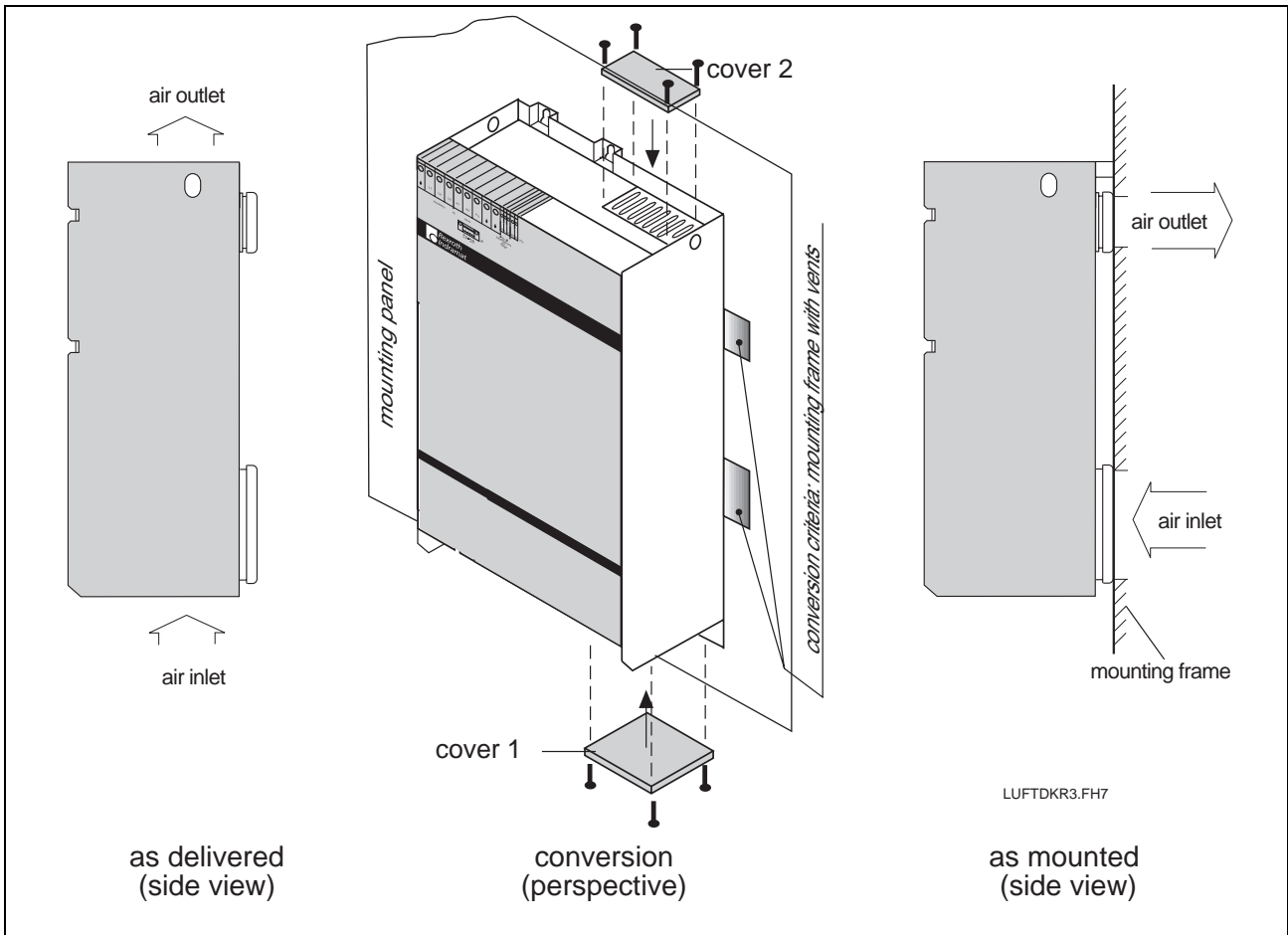

Fig. 10-1: Converting the cooling method to use outside air (DKR02/DKR03)

Conversion to cooling with duct

The parts required for the conversion to "Cooling with duct" can be found in a container marked "M1-RAC3".

For conversion please proceed according to the instructions which are supplied together with the duct cooling accessories.

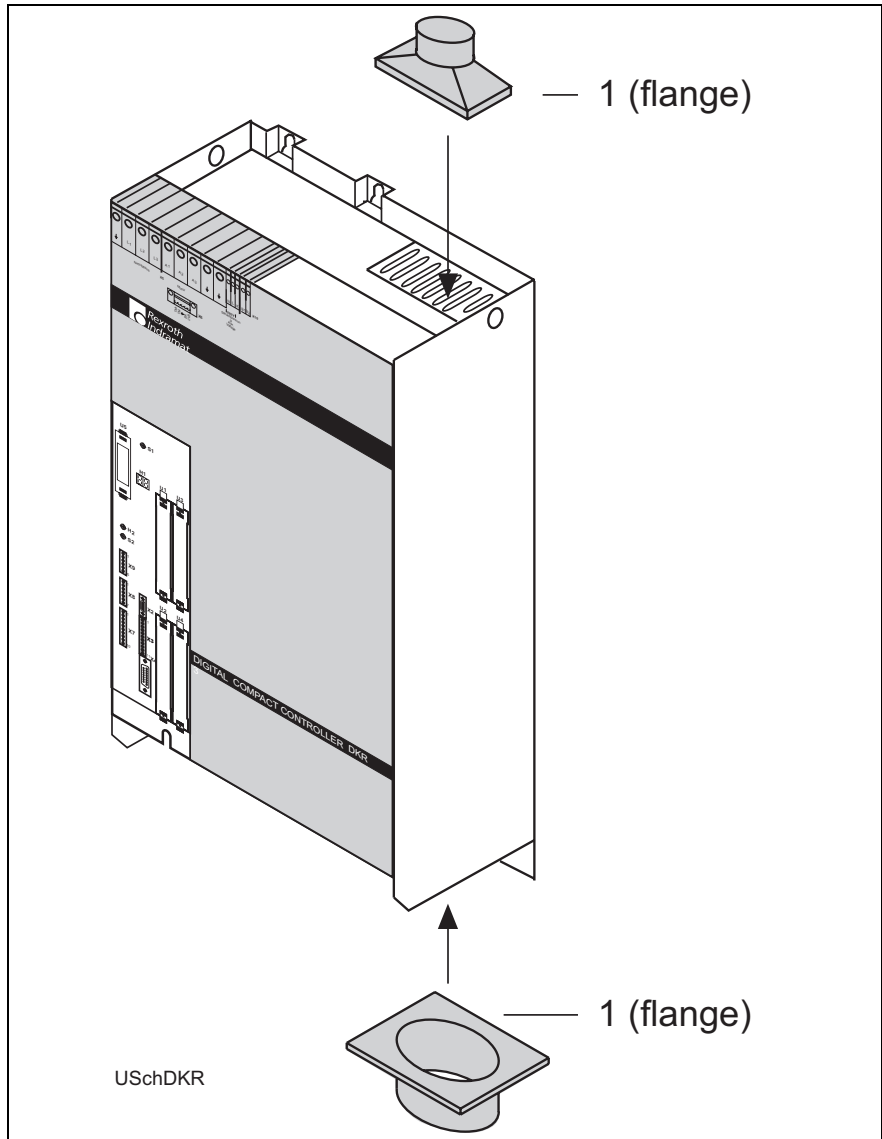

Fig. 10-2: Converting to cooling with duct (DKR02/DKR03)

DKR04

Drive controllers of type DKR04 are supplied for "Cooling with air from outside the cabinet". If a different cooling method is required, then the drive must be converted **before** it is mounted into the cabinet.

Conversion to cooling method using air inside of cabinet

Conversion criteria It is necessary to convert the cooling method, if

- there are no rectangular vents near the controller heatsink in the mounting panel of the control cabinet
- you can see the ventilator through a round opening on the right side of the device to be replaced and the cooling fins of the heatsink on the bottom side (which shows that the device was being operated with air from inside the cabinet).

Note: As a matter of principle observe the specifications of the machine manufacturer or control cabinet maker!

For the conversion to “Cooling with air from inside the cabinet” there are no additional parts required, it is only necessary to dismount installed parts:

1. Remove the round cover (1) on the right side of the device.
2. Remove the cover of the heatsink (2) (on the bottom side of the device). (The screws are accessible from below.)

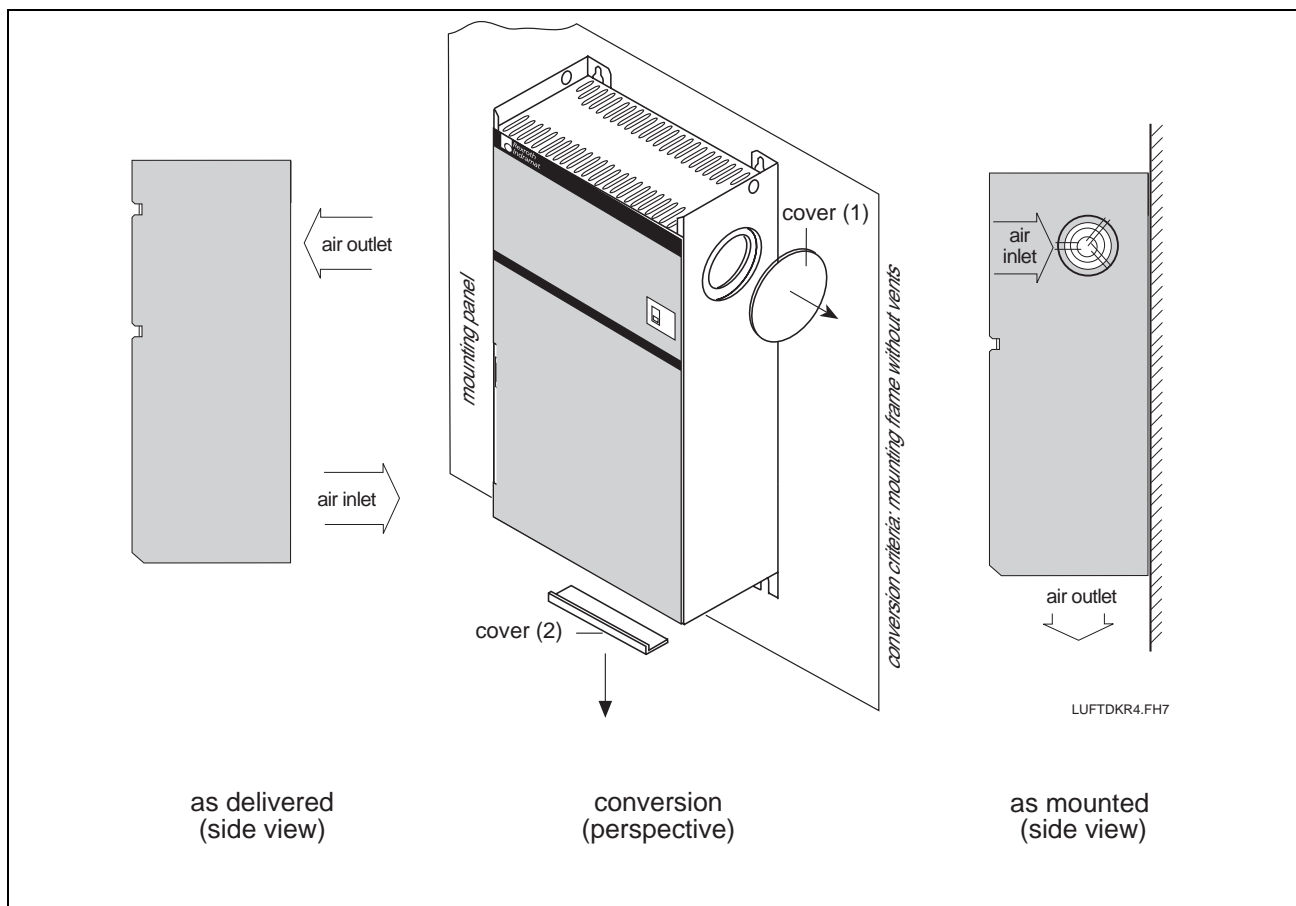

Fig. 10-3: Conversion to cooling method using air inside of cabinet (DKR04)

Conversion to cooling with duct

Note: If you want to make use of the possibility “Cooling with duct”, there mustn't be any vents near the controller heatsink in the mounting panel of the control cabinet.

For the conversion to “Cooling with duct” please proceed as follows:

1. Remove the round cover (1) on the right side of the device.
2. Remove the cover of the heatsink (2) (on the bottom side of the device). (The screws are accessible from below.)
3. Mount the duct cooling accessories (3) according to the instructions supplied together with the accessories.

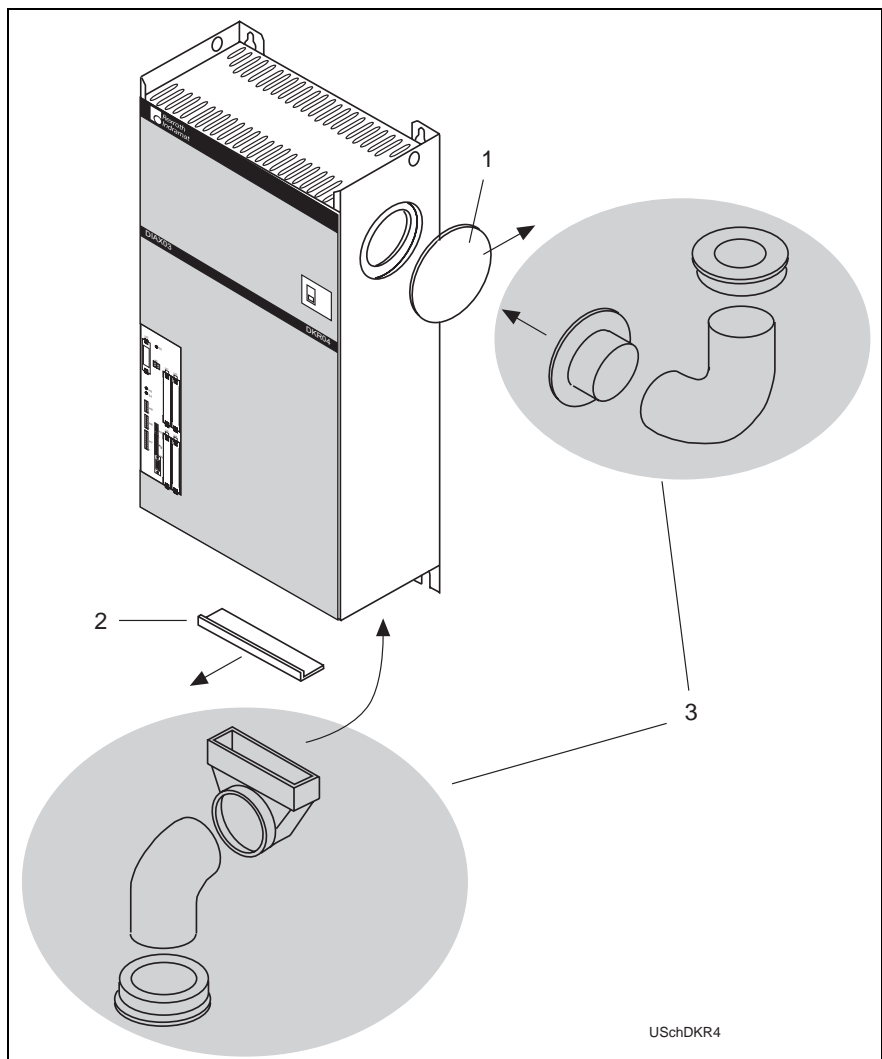

Fig. 10-4: Conversion to cooling with duct (DKR04)

10.2 Mounting the drive



DANGER

Lethal electric shock caused by live parts with more than 50 V!

- ⇒ Switch power off to the control cabinet before beginning work. Make sure that the power supply switch cannot be unintentionally or inadvertently switched back on.
- ⇒ Before starting work, an electrician must check, using appropriate measuring equipment, whether there is any residual voltage in the cabinet or in any of the parts, e.g., from capacitors. Wait their discharge time!

Prerequisites Before mounting the drive controller make the necessary dispositions, such as:

- threaded holes in mounting panel or back wall of cabinet and
- matching fixing bolts.
 - Cooling with air outside:
vents in the back of the mounting.
 - cooling with duct:
vents in the back of the mounting. supports and flange, duct with 80 respectively 125 mm inside diameter.

Note: Ducts are not included in the order. They must be ordered separately and can be ordered from Rexroth Indramat upon request.

- Also make an appropriate lifting device available [for the respective weight of the drive controller please see the technical data (chapter 4)].
- Mounting**
1. *DKR04 only:* Anchor the mounting frame to the back wall of the cabinet or the mounting frame using the included screws (see page 5-15).
 2. Screw the mounting screws into the mounting panel/back wall of cabinet about 2/3 of the way in.
 3. Hang the drive onto the mounting screws.
 4. Tighten the screws. Note the maximum torque given for this procedure.
 5. *Only applies to the cooling method with duct:* Mount the supports and flange for the duct connection to the cabinet at location indicated. Secure the ducts.

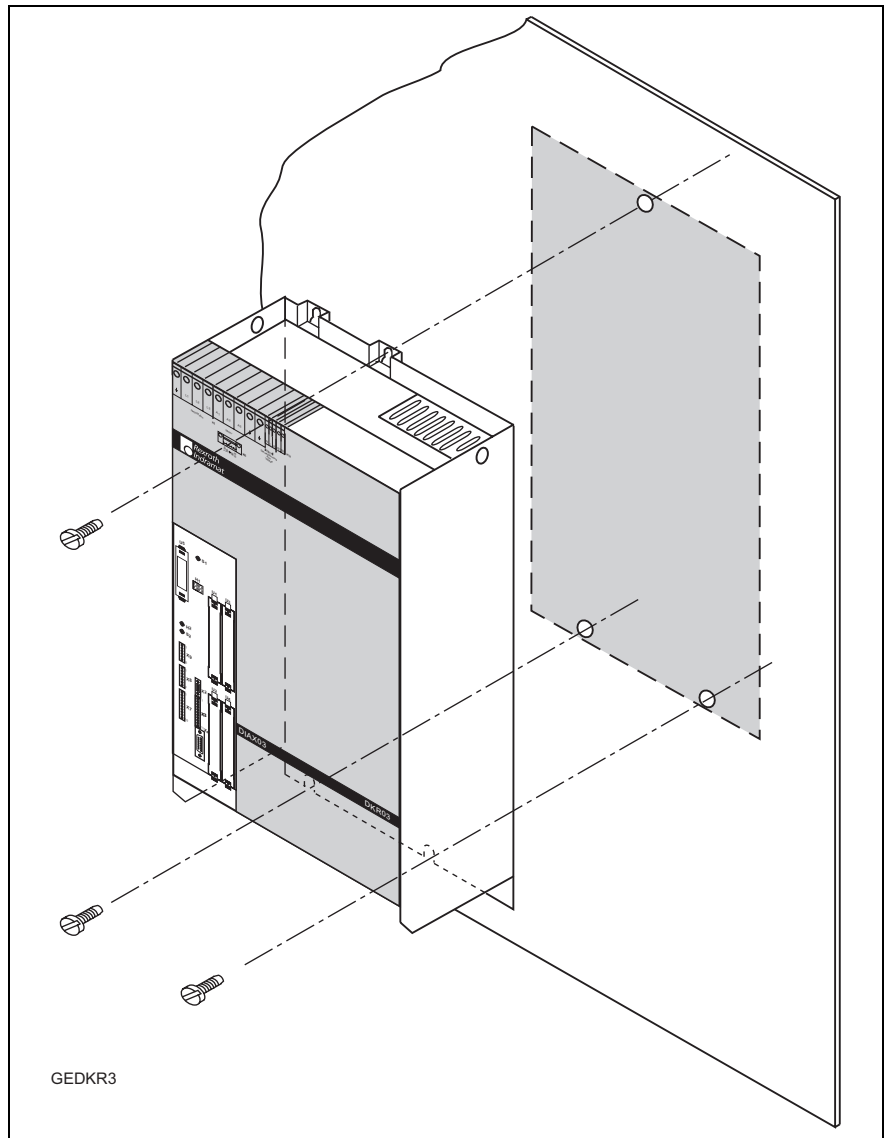

Fig. 10-5: An example for mounting the DKR02/DKR03 (Cooling method: with air from inside the cabinet)

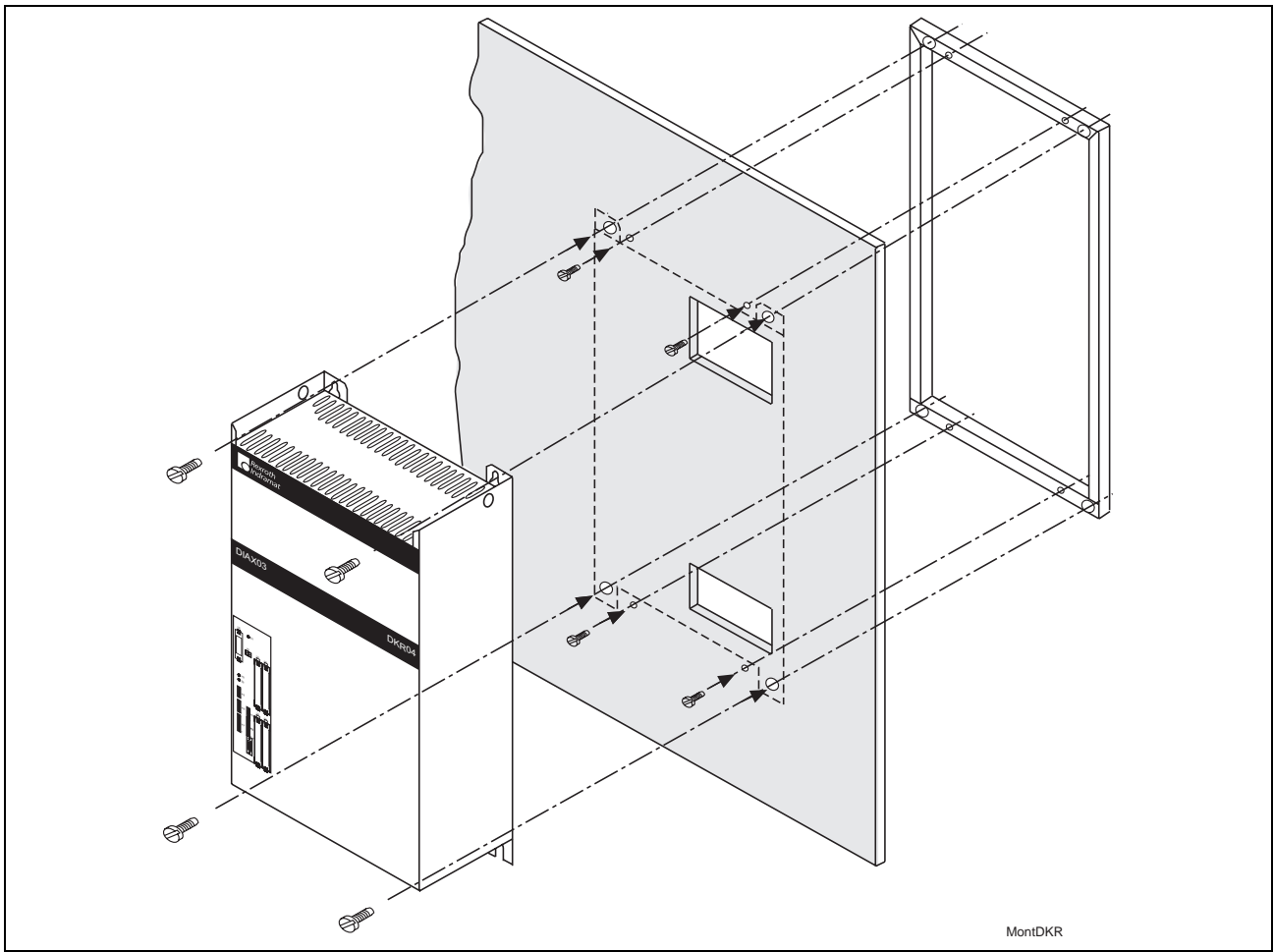

Fig. 10-6: Mounting the DKR04 with mounting frame (Cooling method: with air from outside the control cabinet)

10.3 Drive wiring

Note: All of Rexroth Indramat's terminal connecting diagrams exclusively serve the purpose of generating the circuit diagrams of the machine! The circuit diagrams of the machinery supplied by the manufacturer are to be used when wiring the plant!



Lethal electric shock caused by live parts with more than 50 V!

- ⇒ Only those trained and qualified to work with or on electrical equipment are permitted to operate, maintain or repair this equipment. Electric tools are absolutely required.
 - ⇒ Switch power off to the control cabinet before beginning work. Make sure that the power supply switch cannot be unintentionally or inadvertently switched back on.
 - ⇒ Before starting work, an electrician must check, using appropriate measuring equipment, whether there is any residual voltage in the cabinet or in any of the parts, e.g., from capacitors. Wait their discharge time!
-



Damage to persons or property caused by separation or connection of live leads!

- ⇒ Connect or separate plug-in connectors only if such are dry and not conducting voltage.
 - ⇒ All plug-in connections must be firmly in place while the machine is operating.
-



Danger of short circuit caused by liquid coolant or lubricant!

- ⇒ Make sure when installing or replacing drive components to insert into and seal all open connector ends with protective caps in the event that contamination from a coolant or lubricant could be possible.
 - ⇒ *1MB kit spindle motor with plug-in power connectors:* the backside of the flange socket of the spindle or machine housing may not be contaminated by coolant or lubricant.
-

**CAUTION****Damage to electronic components caused by electrostatic discharge!**

- ⇒ Before working on electronic components and equipment, touch a grounded object as, for example, the doors of the cabinet. This discharges the human body.
- ⇒ Place parts and tools on a grounded surface only.
- ⇒ Use a grounded soldering iron when soldering.

Power connector with double cable

The figure below shows a possibility to connect double cables to a power connector of the DKR04:

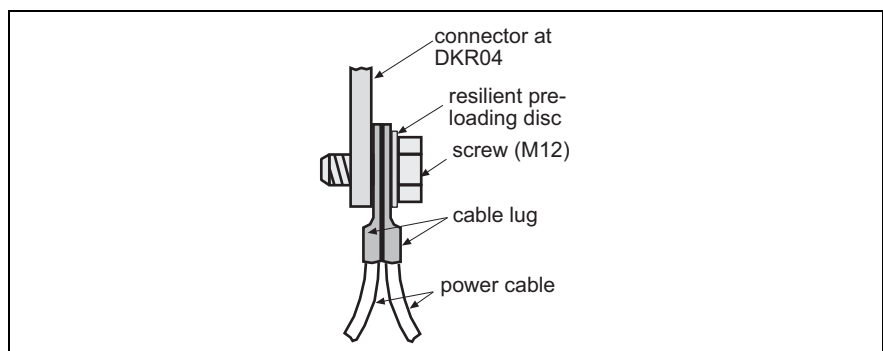

Fig. 10-7: Example: How to fix two leads to a power connector of the DKR04

11 Service and checks

11.1 Error diagnoses

	<p>The drive signals drive problems via</p> <ul style="list-style-type: none"> • the SERCOS interface and • the H1 display on the front of the unit.
Diagnosis by means of documentation	<p>In order to be able to interpret error messages of the drive controller, you need the documentation with the (sub)title "Troubleshooting Guide".</p> <hr/> <p>Note: Windows online help, which describes the error messages of the drive controller, is also available. It can be found in the respective overall help of a firmware version under "Diagnostic Message Description".</p> <hr/> <p>Note: When ordering the documentation please indicate what kind of firmware you use (identify the firmware by means of the rating plate: chapter 9.3).</p> <hr/>
Diagnosis via hotline	<p>If you are not able to resolve a problem, then it is recommended that you contact Rexroth Indramat Customer Service. You will find the telephone number in chapter 13.</p> <p>For a rapid and proper handling of any problems and faults, it is advisable to have certain information handy prior to calling Rexroth Indramat's Customer Service, viz.:</p> <ul style="list-style-type: none"> • the type codes of the affected drives, motors and gearboxes, • a description of the problem and • any fault or display information.
Return of equipment	<p>In the event that any equipment must be returned, please include a completed fault report with the shipment. This will help us pinpoint system- and application-related problems.</p> <hr/> <p>Note: In the documentation with the (sub)title "Troubleshooting Guide" you will find a form of the fault report.</p> <hr/>

11.2 Repairing and replacing units

- Provide replacement device** ⇒ In order to get the highest degree of functional safety, it is advisable to provide the configured drive controller for replacement. See chapter 9 for identification of the drive controller.
- Fill in fault report** ⇒ On page 11-4 you will find a fault report that you should copy. Fill in the fault report thoroughly and completely. The duly completed fault report helps accelerate the repair process and identify application-related faults.
- De-energize** ⇒ Switch power off to the control cabinet before beginning work. Make sure that the power supply switch cannot be unintentionally or inadvertently switched back on.



DANGER

Lethal electric shock caused by contact to live parts of more than 50 V!

- ⇒ Check the installation for complete shutoff by testing the mains terminals for the electronic power and control system with regard to de-energization.

- ⇒ Separate or loosen all electrical and mechanical connections (except for the fixing screws for the device) on the front, top and bottom of the device.
- In case of cooling with a duct remove the ducts from the duct adapters.
 - The cooling agent connections of liquid-cooled devices can be taken off the device with the cooling system filled. The liquid cooling agent won't leak!

Disassemble controller



CAUTION

Hand injuries caused by heavy drive controller with sharp-edged housing!

- ⇒ Use appropriate hoisting gear and protective gloves for disassembly.

- ⇒ Loosen the fixing screws on top and bottom of the device (do not unscrew!). Lift the device off the fixing screws with appropriate hoisting gear (DKR02: approx. 120 kg, DKR03: approx. 49 kg, DKR04: approx. 150 kg) and take it out.
- ⇒ Remove the software module from the faulty device (board U5) and plug it into the replacement device.

Note: The machine-specific parameters are stored in the software module!

If you use the previous software module, it is unnecessary to readjust the drive to the machine!

Convert cooling type of controller, if necessary Check whether the condition as supplied of the replacement device complies with the condition of the faulty device with regard to the cooling system. *DKR02 and DKR03*: Verify the conversion criteria by means of the instructions in chapter "Adapting the cooling method" from page 10-1. *DKR04*: Verify the conversion criteria by means of the instructions in chapter "Adapting the cooling method" from page 10-3.

Install controller



CAUTION

Hand injuries caused by heavy drive controller with sharp-edged housing!

⇒ Use appropriate hoisting gear and protective gloves for installation.

⇒ By means of appropriate hoisting gear, attach the drive controller to the loosened fixing screws. Tighten the screws!

Connect controller



⇒ In accordance with the machine manufacturer's specification, reestablish all electrical connections and, if necessary, the connections for liquid cooling or duct cooling for the drive controller.

Put controller into service again

⇒ In accordance with the machine manufacturer's instructions, put the machine into service again.

⇒ Control the functions and cooling system of the drive controller! After putting liquid-cooled drive controllers into service you have to control the level of the cooling agent in the tank!

11.3 Fault report

	<h2 style="margin:0;">Fault Report</h2> <p style="margin:0;">for digital DKR AC Drives</p>																										
<p>This fault report supports clarification of problems and their causes. It is absolutely necessary for finding and eliminating even hidden, sporadic or application-specific problems.</p> <ul style="list-style-type: none"> - Always include a fault report when sending us a unit. - In any other case, send the fault report to the respective Rexroth Indramat Customer Service office. <p>Rexroth Indramat will process the matter quickly and efficiently.</p>																											
Fault report dated	Co.: _____ Dept.: _____	Loc.: _____ Name: _____	Date: _____ Phone: _____																								
<p>Information about the drive:</p> <div style="display: flex; justify-content: space-between;"> <div style="width: 45%;"> <p>Rating plate of basic unit</p> <p>Type code of basic unit → DKR_ _ _ _ _</p> <p>Coded serial no. → </p> <p>Firmware rating plate</p> <p>Firmware type code → FWA-DIAX03- _ _ _ V_ _ _</p> <p>Coded serial no. → </p> </div> <div style="width: 45%;"> <p>Configuration rating plate</p> <table border="1" style="width:100%; border-collapse: collapse;"> <tr><th colspan="2">SYSTEMCONFIGURATION</th></tr> <tr><td>DKR_ _ _ _ _ -FW</td><td>Type code of the configured drive controller</td></tr> <tr><td>DKR_ _ _ _ _</td><td>Type code of the basic unit</td></tr> <tr><td>U 1 _____</td><td rowspan="5">Type code of the plug-in module</td></tr> <tr><td>U 2 _____</td></tr> <tr><td>U 3 _____</td></tr> <tr><td>U 4 _____</td></tr> <tr><td>U 5 _____</td></tr> <tr><td>K_ _ _ _</td><td>Type designation of the software module</td></tr> <tr><td></td><td>Production week/ year</td></tr> </table> </div> </div> <div style="margin-top: 20px;"> <p>Motor data</p> <p>Type: _____</p> <p>Serial no.: _____</p> </div> <div style="margin-top: 20px;"> <p>Information about machine at which problem occurred:</p> <p>Machine manufacturer: _____ Type: _____ Op. hours: _____</p> <p>Machine no.: _____ Commissioning date: _____</p> <p>Manufacturer and type of machine controller: _____</p> <p>Designation of machine axis in which problem occurred: _____</p> <p>Please describe the problem:</p> <p>_____</p> <p>_____</p> <p>_____</p> </div> <div style="margin-top: 20px;"> <p>Additional information:</p> <table border="1" style="width:100%; border-collapse: collapse;"> <thead> <tr> <th style="width:25%;">Fault status:</th> <th style="width:25%;">Causes:</th> <th style="width:25%;">Other defects:</th> <th style="width:25%;"></th> </tr> </thead> <tbody> <tr> <td> <input type="checkbox"/> occurs permanently <input type="checkbox"/> occurs during commissioning <input type="checkbox"/> occurs sporadically <input type="checkbox"/> occurs after <input type="checkbox"/> hours <input type="checkbox"/> occurs with shocks <input type="checkbox"/> depends on temperature <input type="checkbox"/> Other information: _____ _____ _____ </td> <td> <input type="checkbox"/> unknown <input type="checkbox"/> incorrect connection <input type="checkbox"/> external causes <input type="checkbox"/> mechanical damage <input type="checkbox"/> loose cable connection <input type="checkbox"/> moisture in unit <input type="checkbox"/> foreign body in unit </td> <td> <input type="checkbox"/> problems in mech. system <input type="checkbox"/> power section failure <input type="checkbox"/> control system failure <input type="checkbox"/> motor failure <input type="checkbox"/> cable break <input type="checkbox"/> defective blower <input type="checkbox"/> defective feedback </td> <td> <p>Is there a cooling system in the cabinet ? Y / N <input type="checkbox"/></p> <p>Have there been similar problems before?</p> <p>How often: _____</p> <p>Did the problems occur on certain days or times of the day?</p> <p>_____</p> <p>_____</p> </td> </tr> </tbody> </table> </div>				SYSTEMCONFIGURATION		DKR_ _ _ _ _ -FW	Type code of the configured drive controller	DKR_ _ _ _ _	Type code of the basic unit	U 1 _____	Type code of the plug-in module	U 2 _____	U 3 _____	U 4 _____	U 5 _____	K_ _ _ _	Type designation of the software module		Production week/ year	Fault status:	Causes:	Other defects:		<input type="checkbox"/> occurs permanently <input type="checkbox"/> occurs during commissioning <input type="checkbox"/> occurs sporadically <input type="checkbox"/> occurs after <input type="checkbox"/> hours <input type="checkbox"/> occurs with shocks <input type="checkbox"/> depends on temperature <input type="checkbox"/> Other information: _____ _____ _____	<input type="checkbox"/> unknown <input type="checkbox"/> incorrect connection <input type="checkbox"/> external causes <input type="checkbox"/> mechanical damage <input type="checkbox"/> loose cable connection <input type="checkbox"/> moisture in unit <input type="checkbox"/> foreign body in unit	<input type="checkbox"/> problems in mech. system <input type="checkbox"/> power section failure <input type="checkbox"/> control system failure <input type="checkbox"/> motor failure <input type="checkbox"/> cable break <input type="checkbox"/> defective blower <input type="checkbox"/> defective feedback	<p>Is there a cooling system in the cabinet ? Y / N <input type="checkbox"/></p> <p>Have there been similar problems before?</p> <p>How often: _____</p> <p>Did the problems occur on certain days or times of the day?</p> <p>_____</p> <p>_____</p>
SYSTEMCONFIGURATION																											
DKR_ _ _ _ _ -FW	Type code of the configured drive controller																										
DKR_ _ _ _ _	Type code of the basic unit																										
U 1 _____	Type code of the plug-in module																										
U 2 _____																											
U 3 _____																											
U 4 _____																											
U 5 _____																											
K_ _ _ _	Type designation of the software module																										
	Production week/ year																										
Fault status:	Causes:	Other defects:																									
<input type="checkbox"/> occurs permanently <input type="checkbox"/> occurs during commissioning <input type="checkbox"/> occurs sporadically <input type="checkbox"/> occurs after <input type="checkbox"/> hours <input type="checkbox"/> occurs with shocks <input type="checkbox"/> depends on temperature <input type="checkbox"/> Other information: _____ _____ _____	<input type="checkbox"/> unknown <input type="checkbox"/> incorrect connection <input type="checkbox"/> external causes <input type="checkbox"/> mechanical damage <input type="checkbox"/> loose cable connection <input type="checkbox"/> moisture in unit <input type="checkbox"/> foreign body in unit	<input type="checkbox"/> problems in mech. system <input type="checkbox"/> power section failure <input type="checkbox"/> control system failure <input type="checkbox"/> motor failure <input type="checkbox"/> cable break <input type="checkbox"/> defective blower <input type="checkbox"/> defective feedback	<p>Is there a cooling system in the cabinet ? Y / N <input type="checkbox"/></p> <p>Have there been similar problems before?</p> <p>How often: _____</p> <p>Did the problems occur on certain days or times of the day?</p> <p>_____</p> <p>_____</p>																								

DX3_AT_6.FH7

12 Index

A

- acknowledge
 - power OFF 6-20
 - power ON 6-20
 - power supply 6-20
- air flow data 5-3
- ambient conditions
 - changed 5-1
 - DKR02 4-2
 - DKR03 4-3
 - DKR04 4-4
 - DZB 4-5
- analog output 6-16
- application range 3-1
- appropriate use
 - introduction 1-1
 - uses 1-2
- AS+ / AS- *see* starting lockout
- ASQ contact 6-17
- autotransformer
 - dimensioning 6-11
- auxiliary plug-in module 3-4

B

- basic unit 3-3
- Bb contact 6-16
- Bb1 contact 6-19
- bleeder *see* brake resistor
- bleeder overload *see* TVW contact
- brake resistor 3-5, 6-22
 - ambient conditions 4-5
 - technical data 4-5
 - type code 9-4
 - unit dimensions 5-16
- brake resistor in DKR02
 - technical data 4-1
- brake resistor in DKR03
 - technical data 4-3

C

- command interface card 3-3
- configuration 9-3
- configuring 3-2
- connection allocations 6-3
- connections
 - positions, names and explanations 6-2
- connector kit 7-1
- control inputs for internal power contactors 6-21
- control power contactor 6-21
- control voltage connection 6-21
- cooling 3-2
- cooling method
 - conversion 10-1, 10-3
- cooling method variants 5-4
- cooling unit
 - arrangement 5-7

D

- diagnostic outputs 6-16
- DKR02
 - ambient conditions 4-2

- distances, drill diagram and vents 5-11
- technical data 4-1
- unit dimensions 5-10
- DKR03**
 - ambient conditions 4-3
 - distances, drill diagram and vents 5-13
 - technical data 4-2
 - unit dimensions 5-12
- DKR04**
 - ambient conditions 4-4
 - distances, drill diagram and vents 5-15
 - technical data 4-4
 - unit dimensions 5-14
- drive
 - connecting 10-9
- drive controller
 - mounting 10-6
- duct cooling 7-4
- DZB *see* brake resistor

E

- energy dissipated 5-3
- energy losses 5-3
- error messages 11-1

F

- firmware 3-2
- firmware module 3-3

G

- grounded conductor 6-1

H

- holding brake *see* motor holding brake
- hotline 11-1

I

- identify basic unit *see* rating plate
- inappropriate use 1-2
 - consequences, discharge of liability 1-1
- isolating transformer 6-5
 - dimensioning 6-12

K

- K1NC contact *see* acknowledge power OFF
- K1NO contact *see* acknowledge power ON

L

- lead
 - lead arrangement 5-20
 - length of the leads 5-21
- lead cross section 6-4, 6-9
- leads
 - current load in dependency of ambient temperatures 6-10
 - grounded conductor 6-1
 - motor power cables 6-1
 - type 6-1

M

- mains connection 3-2, 6-4, 6-21
- mains filter 6-9

mains fuse 6-9
motor connection 10-9 *see* power connection
motor feedback 6-17
motor holding brake 6-18
motor power cables 6-1
motor temperature monitoring 6-18

N

NFD *see* mains filter
noise emissions 5-3

O

OFF contact *see* control power contactor
ON contact *see* control power contactor
overvoltage 6-4
overvoltage suppressor 6-6, 6-13

P

plug-in card
 auxiliary plug-in module 3-4
 command interface card 3-3
 firmware module 3-3
power connection 6-21

R

rating plate 9-2
ready for power *see* Bb1 contact
RS-232 interface 6-14
RS-485 interface 6-15

S

safety instructions for electric servo drives and controls 2-1
SERCOS interface 7-3
serial interface 6-14
shock resistance 5-2
signal contact 6-16, 6-19
signal voltages 6-20
starting lockout 6-17

T

temperature pre-warning *see* TVW contact
TVW contact 6-20
type code
 brake resistor 9-4
 drive controller 9-3

U

UD contact *see* acknowledge power supply
use *see* appropriate use *and see* inappropriate use

X

X10 *see* control voltage connection *and* brake resistor
X2 *see* serial interface
X3 *see* analog output *see* signal contact
X4 *see* motor feedback
X5 *see* power connection
X6 *see* motor temperature monitoring *see* motor holding brake
X7 *see* signal contact
X8 *See* signal voltages
X9 *see* control inputs for internal power contactors

13 Service & Support

13.1 Helpdesk

Unser Kundendienst-Helpdesk im Hauptwerk Lohr am Main steht Ihnen mit Rat und Tat zur Seite. Sie erreichen uns

- telefonisch: **+49 (0) 9352 40 50 60**
über Service-Call Entry Center Mo-Fr 07:00-18:00
- per Fax: **+49 (0) 9352 40 49 41**
- per e-Mail: **service@indramat.de**

Our service helpdesk in the head factory Lohr am Main is assisting you in all kind of queries. You may contact us

- by phone: **+49 (0) 9352 40 50 60**
via Service-Call Entry Center Mo-Fr 07:00-18:00
- by fax: **+49 (0) 9352 40 49 41**
- by e-mail: **service@indramat.de**

13.2 Service-Hotline

Außerhalb der Helpdesk-Zeiten ist der Service direkt ansprechbar unter

oder **+49 (0) 171 333 88 26**
+49 (0) 172 660 04 06

Beyond the helpdesk hours, our service is directly contactable under

or **+49 (0) 171 333 88 26**
+49 (0) 172 660 04 06

13.3 Internet – World wide web

Weitere Hinweise zu Service, Reparatur und Training finden Sie im Internet unter

www.indramat.de

Außerhalb Deutschlands nehmen Sie bitte zuerst Kontakt mit Ihrem lokalen Ansprechpartner auf. Die Adressen sind im Anhang aufgeführt.

Further hints about service, repairs and training are available in the world wide web under

www.indramat.de

Please don't hesitate to contact first the sales & service agencies in your area. Refer to the addresses are on the following pages.

13.4 Vor der Kontaktaufnahme... - ...before contacting us...

Wir können Ihnen schnell und effizient helfen wenn Sie folgende Informationen bereithalten:

1. detaillierte Beschreibung der Störung und der Umstände.
2. Angaben auf dem Typenschild der betreffenden Produkte, insbesondere Typenschlüssel und Seriennummern.
3. Telefon-/Faxnummern und e-Mail-Adresse, unter denen Sie für Rückfragen zu erreichen sind.

To enable us for quick and efficient help, please prepare the following information:

1. most detailed description of the failure appearance.
2. Indications on the typelabel of the concerned products, especially typecodes and serialnumbers.
3. Telephone-/faxnumbers and e-mail address by which we can attend you in case of queries.

13.5 Kundenbetreuungsstellen - Sales & Service Facilities

Verkaufsniederlassungen
 Niederlassungen mit Kundendienst

sales agencies
 agencies providing service

Deutschland – Germany

vom Ausland: (0) nach Landeskennziffer weglassen!!
from abroad: don't dial (0) after country code!

Vertriebsgebiet Mitte Germany Centre	SERVICE	SERVICE	SERVICE
Rexroth Indramat GmbH Bgm.-Dr.-Nebel-Str. 2 97816 Lohr am Main Kompetenz-Zentrum Europa Telefon: +49 (0)9352 40-0 Telefax: +49 (0)9352 40-4885	CALL ENTRY CENTER MO – FR von 07:00 - 18:00 Uhr from 7 am – 6 pm Tel. +49 (0) 9352 40 50 60 service@indramat.de	HOTLINE MO – FR von 17:00 - 07:00 Uhr from 5 pm - 7 am + SA / SO Tel.: +49 (0)172 660 04 06 oder / or Tel.: +49 (0)171 333 88 26	ERSATZTEILE / SPARES verlängerte Ansprechzeit - extended office time - ♦ nur an Werktagen - only on working days - ♦ von 07:00 - 18:00 Uhr - from 7 am - 6 pm - Tel. +49 (0) 9352 40 42 22
Vertriebsgebiet Süd Germany South Rexroth Indramat GmbH Ridlerstraße 75 80339 München Telefon: +49 (0)89 540138-30 Telefax: +49 (0)89 540138-10 indramat.mue@t-online.de	Gebiet Südwest Germany South-West Mannesmann Rexroth AG Vertrieb Deutschland – VD-BI Geschäftsbereich Rexroth Indramat Regionalzentrum Südwest Ringstrasse 70 / Postfach 1144 70736 Fellbach / 70701 Fellbach Tel.: +49 (0)711 57 61-100 Fax: +49 (0)711 57 61-125	Vertriebsgebiet Ost Germany East Rexroth Indramat GmbH Beckerstraße 31 09120 Chemnitz Telefon: +49 (0)371 35 55-0 Telefax: +49 (0)371 35 55-333	Vertriebsgebiet Nord Germany North Mannesmann Rexroth AG Vertriebsniederlassung Region Nord Gesch.ber. Rexroth Indramat Walsroder Str. 93 30853 Langenhagen Telefon: +49 (0) 511 72 66 57-0 Telefax: +49 (0) 511 72 66 57-93
Vertriebsgebiet West Germany West Mannesmann Rexroth AG Vertrieb Deutschland Regionalzentrum West Borsigstrasse 15 40880 Ratingen Telefon: +49 (0)2102 409-0 Telefax: +49 (0)2102 409-406	Vertriebsgebiet Mitte Germany Centre Mannesmann Rexroth AG Gesch.ber. Rexroth Indramat Lilistraße 14-18 63067 Offenbach Telefon: +49 (0) 69 82 00 90-0 Telefax: +49 (0) 69 82 00 90-80	Vertriebsgebiet Ost Germany East Mannesmann Rexroth AG GB Rexroth Indramat GmbH Holzhäuser Str. 122 04299 Leipzig Telefon: +49 (0)341 86 77-0 Telefax: +49 (0)341 86 77-219	Vertriebsgebiet Nord Germany North Rexroth Indramat GmbH Kieler Straße 212 22525 Hamburg Telefon: +49 (0)40 85 31 57-0 Telefax: +49 (0)40 85 31 57-15

Europa – Europe

vom Ausland: (0) nach Landeskennziffer weglassen, **Italien:** 0 nach Landeskennziffer mitwählen
from abroad: don't dial (0) after country code, **Italy:** dial 0 after country code

Austria Mannesmann Rexroth Ges.m.b.H. Gesch.ber. Rexroth Indramat Hägelingasse 3 1140 Wien Telefon: +43 (0)1 9852540-400 Telefax: +43 (0)1 9852540-93	Austria Mannesmann Rexroth G.m.b.H. Gesch.ber. Rexroth Indramat Industriepark 18 4061 Pasching Telefon: +43 (0)7221 605-0 Telefax: +43 (0)7221 605-21	Belgium Mannesmann Rexroth N.V.-S.A. Gesch.ber. Rexroth Indramat Industrielaan 8 1740 Ternat Telefon: +32 (0)2 5830719 Telefax: +32 (0)2 5830731 indramat@rexroth.be	Denmark BEC AS Zinkvej 6 8900 Randers Telefon: +45 (0)87 11 90 60 Telefax: +45 (0)87 11 90 61
Czech Republic Mannesmann-Rexroth, spol.s.r.o. Hviezdoslavova 5 627 00 Brno Telefon: +420 (0)5 48 126 358 Telefax: +420 (0)5 48 126 112	England Mannesmann Rexroth Ltd. Rexroth Indramat Division Broadway Lane, South Cerney Cirencester, Glos GL7 5UH Telefon: +44 (0)1285 863000 Telefax: +44 (0)1285 863030	Finland Rexroth Mecman Oy Rexroth Indramat division Ansatie 6 017 40 Vantaa Telefon: +358 (0)9 84 91-11 Telefax: +358 (0)9 84 91-13 60	France Mannesmann Rexroth S.A. Division Rexroth Indramat Parc des Barbanniers 4, Place du Village 92632 Gennevilliers Cedex Telefon: +33 (0)141 47 54 30 Telefax: +33 (0)147 94 69 41 Hotline: +33 (0)608 33 43 28
France Mannesmann Rexroth S.A. Division Rexroth Indramat 270, Avenue de Lardenne 31100 Toulouse Telefon: +33 (0)5 61 49 95 19 Telefax: +33 (0)5 61 31 00 41	France Mannesmann Rexroth S.A. Division Rexroth Indramat 91, Bd. Irène Joliot-Curie 69634 Vénissieux – Cedex Telefon: +33 (0)4 78 78 53 65 Telefax: +33 (0)4 78 78 53 62	Hungary Mannesmann Rexroth Kft. Angol utca 34 1149 Budapest Telefon: +36 (1) 364 00 02 Telefax: +36 (1) 383 19 80	Italy Mannesmann Rexroth S.p.A. Divisione Rexroth Indramat Via G. Di Vittoria, 1 20063 Cernusco S/N.MI Telefon: +39 02 2 365 270 Telefax: +39 02 700 408 252378
Italy Mannesmann Rexroth S.p.A. Divisione Rexroth Indramat Via Borgomanero, 11 10145 Torino Telefon: +39 011 7 50 38 11 Telefax: +39 011 7 71 01 90	Italy Mannesmann Rexroth S.p.A. Divisione Rexroth Indramat Via del Progresso, 16 (Zona Ind.) 35020 Padova Telefon: +39 049 8 70 13 70 Telefax: +39 049 8 70 13 77	Italy Mannesmann Rexroth S.p.A. Divisione Rexroth Indramat Via Mascia, 1 80053 Castellammare di Stabia NA Telefon: +39 081 8 71 57 00 Telefax: +39 081 8 71 68 85	Italy Mannesmann Rexroth S.p.A. Divisione Rexroth Indramat Viale Oriani, 38/A 40137 Bologna Telefon: +39 051 34 14 14 Telefax: +39 051 34 14 22
Netherlands Rexroth B.V. Kruisbroeksestraat 1 (P.O. Box 32) 5281 RV Boxtel Telefon: +31 (0)411 65 19 51 Telefax: +31 (0)411 65 14 83 indramat@hydraudyne.nl	Netherlands Rexroth Hydrocare B.V. Kruisbroeksestraat 1 (P.O. Box 32) 5281 RV Boxtel Telefon: +31 (0)411 65 19 51 Telefax: +31 (0)411 67 78 14	Norway Rexroth Mecman AS Rexroth Indramat Division Berghagan 1 or: Box 3007 1405 Ski-Langhus 1402 Ski Telefon: +47 (0)64 86 41 00 Telefax: +47 (0)64 86 90 62	Poland Mannesmann Rexroth Sp.zo.o. Biuro Poznan ul. Dabrowskiego 81/85 60-529 Poznan Telefon: +48 061 847 67 99 Telefax: +48 061 847 64 02
Rumania Mannesmann Rexroth Sp.zo.o. Str. Drobety nr. 4-10, app. 14 70258 Bucuresti, Sector 2 Telefon: +40 (0)1 210 48 25 +40 (0)1 210 29 50 Telefax: +40 (0)1 210 29 52	Russia Tschudnenko E.B. Arsenia 22 153000 Ivanovo Telefon: +7 093 223 96 33 oder/or +7 093 223 95 48 Telefax: +7 093 223 46 01	Spain Mannesmann Rexroth S.A. Division Rexroth Indramat Centro Industrial Santiga Obradors s/n 08130 Santa Perpetua de Mogoda Barcelona Telefon: +34 9 37 47 94 00 Telefax: +34 9 37 47 94 01	Spain Goimendi S.A. Division Rexroth Indramat Parque Empresarial Zuatzu C/ Francisco Montagne no.2 20018 San Sebastian Telefon: +34 9 43 31 84 21 - service: +34 9 43 31 84 56 Telefax: +34 9 43 31 84 27 - service: +34 9 43 31 84 60 satindramat-goimendi@adegi.es
Sweden Rexroth Mecman Svenska AB Rexroth Indramat Division Varuvägen 7 125 81 Stockholm Telefon: +46 (0)8 727 92 00 Telefax: +46 (0)8 647 32 77	Slowenia Rexroth Indramat elektromotorji d.o.o. Otoki 21 64 228 Zelezniki Telefon: +386 64 61 73 32 Telefax: +386 64 64 71 50	Switzerland -East- Mannesmann Rexroth Schweiz AG Gesch.ber. Rexroth Indramat Gewerbestraße 3 8500 Frauenfeld Telefon: +41 (0)52 720 21 00 Telefax: +41 (0)52 720 21 11	Switzerland -West- Mannesmann Rexroth Suisse SA Département Rexroth Indramat Rue du village 1 1020 Renens Telefon: +41 (0)21 632 84 20 Telefax: +41 (0)21 632 84 21
Turkey Mannesmann Rexroth Hidropar A..S. Fevzi Cakmak Cad No. 3 34630 Sefaköy Istanbul Telefon: +90 212 541 60 70 Telefax: +90 212 599 34 07			

Africa, Asia, Australia – incl. Pacific Rim

vom Ausland:
from abroad:

(x) nach Landeskennziffer weglassen!
don't dial (x) after country code!

<p>Australia</p> <p>AIMS - Australian Industrial Machinery Services Pty. Ltd. Unit 3/45 Horne ST Campbellfield , VIC 3061 Melbourne</p> <p>Telefon: +61 (0)3 93 59 02 28 Telefax: +61 (0)3 93 59 02 86</p>	<p>Australia</p> <p>Mannesmann Rexroth Pty. Ltd. No. 7, Endeavour Way Braeside Victoria, 31 95 Melbourne</p> <p>Telefon: +61 (0)3 95 80 39 33 Telefax: +61 (0)3 95 80 17 33 mel@rexroth.com.au</p>	<p>China</p> <p>Shanghai Mannesmann Rexroth Hydraulics & Automation Ltd. Wai Gaoqiao Free Trade Zone No.122, Fu Te Dong Yi Road Shanghai 200131 - P.R.China</p> <p>Telefon: +86 21 58 66 30 30 Telefax: +86 21 58 66 55 23</p>	<p>China</p> <p>Mannesmann Rexroth (China) Ltd. 15/F China World Trade Center 1, Jianguomenwai Avenue Beijing 100004, P.R.China</p> <p>Telefon: +86 10 65 05 03 80 Telefax: +86 10 65 05 03 79</p>
<p>China</p> <p>Mannesmann Rexroth (China) Ltd. A-5F., 123 Lian Shan Street Sha He Kou District Dalian 116 023, P.R.China</p> <p>Telefon: +86 411 46 78 930 Telefax: +86 411 46 78 932</p>	<p>China</p> <p>Mannesmann Rexroth (China) Ltd. Guangzhou Repres. Office Room 1014-1016, Metro Plaza, Tian He District, 183 Tian He Bei Rd Guangzhou 510075, P.R.China</p> <p>Telefon: +86 20 8755-0030 +86 20 8755-0011 Telefax: +86 20 8755-2387</p>	<p>Hongkong</p> <p>Rexroth (China) Ltd. 1/F., 19 Cheung Shun Street Cheung Sha Wan, Kowloon, Hongkong</p> <p>Telefon: +852 22 62 51 00 Telefax: +852 27 41 33 44</p>	<p>India</p> <p>Mannesmann Rexroth (India) Ltd. Rexroth Indramat Division Plot. A-58, TTC Industrial Area Thane Turbhe Midc Road Mahape Village Navi Mumbai - 400 701</p> <p>Telefon: +91 (0)22 7 61 46 22 Telefax: +91 (0)22 7 68 15 31</p>
<p>India</p> <p>Mannesmann Rexroth (India) Ltd. Rexroth Indramat Division Plot. 96, Phase III Peenya Industrial Area Bangalore - 560058</p> <p>Telefon: +91 (0)80 8 39 73 74 Telefax: +91 (0)80 8 39 43 45</p>	<p>Indonesia</p> <p>PT. Rexroth Wijayakusuma Jl. Raya Bekasi Km 21 Pulogadung Jakarta Timur 13920</p> <p>Telefon: +62 21 4 61 04 87 +62 21 4 61 04 88 Telefax: +62 21 4 60 01 52</p>	<p>Japan</p> <p>Rexroth Automation Co., Ltd. Service Center Japan Yutakagaoka 1810, Meito-ku, NAGOYA 465-0035, Japan</p> <p>Telefon: +81 (0)52 777 88 41 +81 (0)52 777 88 53 +81 (0)52 777 88 79 Telefax: +81 (0)52 777 89 01</p>	<p>Japan</p> <p>Rexroth Automation Co., Ltd. Rexroth Indramat Division 1F, I.R. Building Nakamachidai 4-26-44, Tsuzuki-ku YOKOHAMA 224-0041, Japan</p> <p>Telefon: +81 (0)45 942 72 10 Telefax: +81 (0)45 942 03 41</p>
<p>Korea</p> <p>Mannesmann Rexroth-Korea Ltd. Rexroth Indramat Division 1500-12 Dadae-Dong- Saha-Ku Pusan, 604-050 Republic of South Korea</p> <p>Telefon: +82 (0)51 26 00 741 Telefax: +82 (0)51 26 00 747 gyhan@rexrothkorea.co.kr</p>	<p>South Africa</p> <p>TECTRA Automation (Pty) Ltd. 28 Banfield Road, Industria North RSA - Maraisburg 1700</p> <p>Telefon: +27 (0)11 673 20 80 Telefax: +27 (0)11 673 72 69</p>	<p>Taiwan</p> <p>Rexroth Uchida Co., Ltd. No.17, Lane 136, Cheng Bei 1 Rd., Yungkang, Tainan Hsien Taiwan, R.O.C.</p> <p>Telefon: +886 (0)6 25 36 565 Telefax: +886 (0)6 25 34 754</p>	<p>Thailand</p> <p>NC Advance Technologies Co. Ltd. 59/76 Moo 9 Soi Ramintra 34 Ramintra Road, Tharang, Bangkhen Bangkok 10220</p> <p>Telefon: +66 2 943 70 62 +66 2 943 71 21 Telefax: +66 2 509 23 62 sonkawin@hotmail.com</p>

Nordamerika – North America

<p>USA</p> <p>Mannesmann Rexroth Corporation Rexroth Indramat Division 5150 Prairie Stone Parkway Hoffman Estates, IL 60192-3707</p> <p>Competence Centre America</p> <p>Telefon: +1 847 6 45 36 00 Telefax: +1 847 6 45 62 01 service@indramat.com</p>	<p>USA</p> <p>Mannesmann Rexroth Corporation Rexroth Indramat Division Central Region Technical Center Auburn Hills, MI 48326</p> <p>Telefon: +1 248 3 93 33 30 Telefax: +1 248 3 93 29 06</p>	<p>USA</p> <p>Mannesmann Rexroth Corporation Rexroth Indramat Division Southeastern Technical Center 3625 Swiftwater Park Drive Suwanee, Georgia 30174</p> <p>Telefon: +1 770 9 32 32 00 Telefax: +1 770 9 32 19 03</p>	<p>USA</p> <p>HOTLINE</p> <p>- 7 days x 24hrs -</p> <p>+1-800-860-1055</p>
<p>USA</p> <p>Mannesmann Rexroth Corporation Rexroth Indramat Division Charlotte Regional Sales Office 14001 South Lakes Drive Charlotte, North Carolina 28273</p> <p>Telefon: +1 704 5 83 97 62 +1 704 5 83 14 86</p>	<p>USA</p> <p>Mannesmann Rexroth Corporation Rexroth Indramat Division Northeastern Technical Center 99 Rainbow Road East Granby, Connecticut 06026</p> <p>Telefon: +1 860 8 44 83 77 Telefax: +1 860 8 44 85 95</p>	<p>Canada East</p> <p>Basic Technologies Corporation Burlington Division 3426 Mainway Drive Burlington, Ontario Canada L7M 1A8</p> <p>Telefon: +1 905 335 55 11 Telefax: +1 905 335-41 84</p>	<p>Canada West</p> <p>Basic Automation Burnaby 5345 Goring St. Burnaby, British Columbia Canada V7J 1R1</p> <p>Tel. +1 604 205-5777 Fax +1 604 205-6944 dave.gunby@basic.ca</p>

Südamerika – South America

<p>Argentina</p> <p>Mannesmann Rexroth S.A.I.C. Division Rexroth Indramat Acassuso 48 41/7 RA - 1605 Munro (Buenos Aires)</p> <p>Telefon: +54 (0)11 4756 01 40 Telefax: +54 (0)11 4762 6862 mannesmann@mannesmannsaic.com.ar</p>	<p>Argentina</p> <p>NAKASE Servicio Tecnico CNC Calle 49, No. 5764/66 RA - 1653 Villa Balester Prov. - Buenos Aires</p> <p>Telefon: +54 (0) 11 4768 36 43 Telefax: +54 (0) 11 4768 24 13 nakase@usa.net nakase@infovia.com.ar</p>	<p>Brazil</p> <p>Mannesmann Rexroth Automação Ltda. Divisão Rexroth Indramat Rua Georg Rexroth, 609 Vila Padre Anchieta BR - 09951-270 Diadema-SP [Caixa Postal 377] [BR-09901-970 Diadema-SP]</p> <p>Telefon: +55 (0)11 4075 90 60 +55 (0)11 4075 90 70 Telefax: +55 (0)11 4075 35 52 awittwer@rexroth.com.br</p>	<p>Brazil</p> <p>Mannesmann Rexroth Automação Ltda. Divisão Rexroth Indramat R. Dr.Humberto Pinheiro Vieira, 100 Distrito Industrial BR - 89220-390 Joinville - SC [Caixa Postal 1273]</p> <p>Tel./Fax: +55 (0)47 473 58 33 Mobil: +55 (0)47 974 66 45 prochnow@zaz.com.br</p>
<p>Mexico</p> <p>Mannesmann Rexroth Mexico S.A. de C.V. Calle Neptuno 72 Unidad Ind. Vallejo MEX - 07700 Mexico, D.F.</p> <p>Telefon: +52 5 754 17 11 +52 5 754 36 84 +52 5 754 12 60 Telefax: +52 5 754 50 73 +52 5 752 59 43</p>			

Notes



Printed in Germany

