

Rexroth MHD Synchronous motors

273697
Edition 05

Project Planning Manual



Title	Rexroth MHD Synchronous motors
Type of Documentation	Project Planning Manual
Document Typecode	DOK-MOTOR*-MHD*****-PR05-EN-P
Internal File Reference	Document Number: 120-1500-B307-05-EN MNR: 273697
Purpose of Documentation	This documentation helps ... <ul style="list-style-type: none"> • In the familiarisation with digital MHD AC Motors • To plan the mechanical integration into the installation • To plan the electrical connections • To connect the motor • To order or identify a motor To determine the required motor cable and connector

Record of Revisions

Description	Release Date	Notes
DOK-MOTOR*-MHD*****-PRJ1-EN-P	10.96	1 st edition
DOK-MOTOR*-MHD*****-PRJ2-EN-P	11.98	Newly included MHD041A, MHD071A, MHD090, MHD112, correction of technical data
DOK-MOTOR*-MHD*****-PR03-EN-P	09.99	Revision
DOK-MOTOR*-MHD*****-PR05-EN-P	12.01	Revision
DOK-MOTOR*-MHD*****-PR05-EN-P	07.03	Revision

Copyright	© 2003 Bosch Rexroth AG Copying this document, giving it to others and the use or communication of the contents thereof without express authority, are forbidden. Offenders are liable for the payment of damages. All rights are reserved in the event of the grant of a patent or the registration of a utility model or design (DIN 34-1).
Validity	The specified data is for product description purposes only and may not be deemed to be guaranteed unless expressly confirmed in the contract. All rights are reserved with respect to the content of this documentation and the availability of the product.
Published by	Bosch Rexroth AG Bgm.-Dr.-Nebel-Str. 2 • D-97816 Lohr a. Main Telephone +49 (0)93 52/40-0 • Tx 68 94 21 • Fax +49 (0)93 52/40-48 85 http://www.boschrexroth.com/ Dept. BRC/EDM2 (JW)
Note	This document has been printed on chlorine-free bleached paper.

Contents

1	Introduction	1-1
1.1	Introduction to the Product.....	1-1
1.2	About this Documentation.....	1-3
2	Important Instructions on Use	2-1
2.1	Intended Use	2-1
	Introduction	2-1
	Fields of Use and Application	2-2
2.2	Non-Intended Use.....	2-2
3	Safety Instructions for Electric Drives and Controls	3-1
3.1	Introduction	3-1
3.2	Explanations	3-1
3.3	Hazards by Improper Use.....	3-2
3.4	General Information	3-3
3.5	Protection Against Contact with Electrical Parts.....	3-5
3.6	Protection Against Electric Shock by Protective Low Voltage (PELV)	3-6
3.7	Protection Against Dangerous Movements	3-7
3.8	Protection Against Magnetic and Electromagnetic Fields During Operation and Mounting	3-9
3.9	Protection Against Contact with Hot Parts.....	3-10
3.10	Protection During Handling and Mounting.....	3-10
3.11	Battery Safety	3-11
3.12	Protection Against Pressurized Systems.....	3-11
4	MHD Type Code	4-1
5	General Notes on Technical Data	5-1
5.1	60-K and 100-K Parameters	5-1
5.2	Operating Modes	5-2
5.3	Definition of Parameters	5-3
5.4	Sample Curve	5-5
6	MHD041	6-1
6.1	Technical data	6-1
	Holding brake.....	6-3
6.2	Type Code – Ordering Name	6-4
6.3	Speed-Torque Curves	6-5

6.4	Shaft loads	6-6
6.5	Dimensional Details	6-7
7	MHD071	7-1
7.1	Technical data	7-1
	Holding brake.....	7-4
7.2	Type Code – Ordering Name	7-5
7.3	Speed-Torque Curves	7-6
7.4	Shaft loads.....	7-8
7.5	Dimensional Details	7-9
7.6	Blower Units.....	7-10
8	MHD090	8-1
8.1	Technical data	8-1
	Holding brake.....	8-4
8.2	Type Code – Ordering Name	8-5
8.3	Speed-Torque Curves	8-6
8.4	Shaft loads.....	8-8
8.5	Dimensional Details	8-9
8.6	Blower Units.....	8-10
9	MHD093	9-1
9.1	Technical data	9-1
	Holding brake.....	9-10
	Technical Data liquid coolant.....	9-10
9.2	Type Code – Ordering Name	9-11
9.3	Speed-Torque Curves	9-12
9.4	Shaft loads.....	9-16
9.5	Dimensional Details (Standard Cooling).....	9-17
9.6	Blower Units.....	9-18
9.7	Dimensional Details (Liquid Cooling).....	9-20
10	MHD095	10-1
10.1	Technical data	10-1
	Holding brake.....	10-10
10.2	Type Code – Ordering Name	10-11
10.3	Speed-Torque Curves	10-12
10.4	Shaft loads.....	10-16
10.5	Dimensional Details (Standard Cooling).....	10-17
10.6	Blower Units.....	10-18
11	MHD112	11-1
11.1	Technical data	11-1
	Holding brake.....	11-13
11.2	Type Code – Ordering Name	11-14
11.3	Speed-Torque Curves	11-16

11.4	Shaft loads	11-21
11.5	Dimensional Details	11-22
11.6	Blower Units.....	11-24
12	MHD115	12-1
12.1	Technical data	12-1
	Holding brake.....	12-10
	Technical Data liquid coolant.....	12-10
12.2	Type Code – Ordering Name	12-11
12.3	Speed-Torque Curves	12-12
12.4	Shaft loads.....	12-16
12.5	Dimensional Details	12-17
12.6	Fan Units.....	12-19
13	MHD131	13-1
13.1	Technical data	13-1
	Holding brake.....	13-3
13.2	Type Code – Ordering Name	13-4
13.3	Speed-Torque Curves	13-5
13.4	Shaft loads.....	13-6
13.5	Dimensional Details	13-7
13.6	Blower Units.....	13-11
14	Accessories	14-1
	Sealing Air Connection Accessories.....	14-1
	Transmission.....	14-2
	GTS, GTP, GTM Planetary Gearings.....	14-2
	Worm Gears 058	14-3
15	Connection System	15-1
15.1	Overview of Connections.....	15-1
15.2	Power Connector	15-2
	Overview	15-2
15.3	Encoder connection	15-3
	Flange socket	15-3
15.4	Blower connection	15-3
	Design (1)	15-4
	Design (2) -3-pin.....	15-6
	Design (3) -4-pin.....	15-8
15.5	Connection Cable	15-9
16	Notes Application	16-1
16.1	Conditions for use.....	16-1
	Setup Height and Ambient Temperature.....	16-1
	Vibration and shock loading	16-2
16.2	Protection class	16-3

Option sealing air "sealing air: principle" connection.....	16-4
Selecting the Degree of Protection.....	16-5
16.3 Design and Installation Positions.....	16-6
Prime Coat and Housing Varnish	16-6
16.4 Blowers	16-7
16.5 Liquid Cooling	16-9
Connection Instructions	16-10
16.6 Holding Brakes	16-11
Selecting Holding Brakes	16-12
Sizing of Holding Brakes (Application)	16-13
16.7 Output Shaft and Motor Bearing.....	16-14
Plain Shaft	16-14
Output Shaft With Featherkey	16-14
Output Shaft With Shaft Sealing Ring	16-15
Bearings and Shaft Load	16-16
16.8 Motor encoder.....	16-18
Technical data of motor encoder	16-18
16.9 Acceptances, Approvals	16-19
CE symbol	16-19
UR, cUR Listing	16-19
17 Handling	17-1
17.1 Identifying the Goods.....	17-1
17.2 Type Labels	17-1
17.3 Instructions on the Packing.....	17-2
17.4 Storage	17-3
17.5 Transport and Handling	17-3
18 Assembly	18-1
18.1 Skilled Technical Personnel.....	18-1
18.2 Mounting the Motor.....	18-1
18.3 Connecting the Motor	18-3
Connecting Cable Sets.....	18-4
Changing the Output Direction of Power and Feedback Connectors	18-5
19 Startup, Operation, and Maintenance	19-1
19.1 Commissioning	19-1
19.2 Operation	19-1
19.3 Maintenance	19-2
Cleaning.....	19-2
Bearing	19-2
Connection Lines	19-2
Holding Brake	19-3
20 Appendix	20-1
20.1 List of standards	20-1

20.2	Selecting Power Cables.....	20-3
	INS0680, 1.0mm ²	20-7
	INS0680, 1.5mm ²	20-8
	INS0680, 2.5mm ²	20-9
	INS0480, 1.5mm ²	20-10
	INS0480, 2.5mm ²	20-11
	INS0480, 4.0mm ²	20-12
	INS0480, 6.0mm ²	20-13
	INS0480, 10.0mm ²	20-14
	INS0380, 6.0mm ²	20-15
	INS0380, 10.0mm ²	20-16
	INS0380, 16.0mm ²	20-17
	INS0380, 25.0mm ²	20-18
	INS0380, 35.0mm ²	20-19
20.3	Selecting Encoder Cables	20-20
21	Index	21-1
22	Service & Support	22-1
22.1	Helpdesk.....	22-1
22.2	Service-Hotline	22-1
22.3	Internet.....	22-1
22.4	Vor der Kontaktaufnahme... - Before contacting us... ..	22-1
22.5	Kundenbetreuungsstellen - Sales & Service Facilities	22-2

1 Introduction

This chapter describes how to use the present documentation (refer to the chapter entitled “About this Documentation”) and includes a general representation of the product in Chapter 1.1.

1.1 Introduction to the Product

Fields of application In connection with the digital intelligent drive controllers by Bosch Rexroth, the MHD synchronous motors offer cost-effective automation systems with an extensive functionality for the following fields of application:

- Machine tools
- Printing and paper industries
- Handling and automation
- Packaging machines and food

Motors with the following continuous torques at standstill are available:

Performance overview

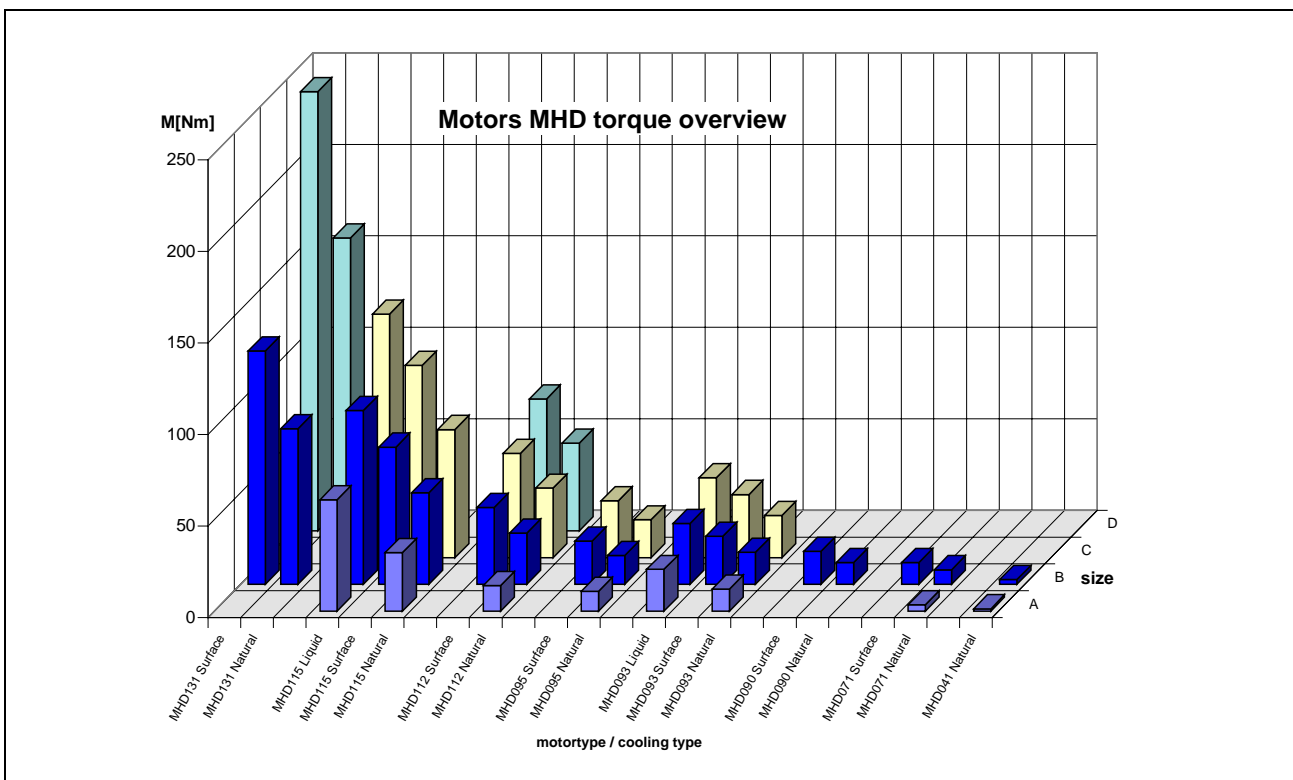

Fig. 1-1: Continuous torques at standstill of the available MHD motors

Benefits MHD motors are characterized by the following advantages:

- High operational reliability
- Maintenance-free operation (owing to the brushless design and use of bearings grease-lubricated for their entire service life)

- Use under adverse environmental conditions is possible (owing to the completely closed motor design in IP 65 degree of protection)
- Overload protection (owing to motor temperature monitoring)
- High performance data
- High dynamics (owing to the favorable ratio of torque to inertia mass)
- High overload capability (owing to the favorable heat dissipation from the stator windings to the outside wall of the motor housing)
- Peak torque utilizable across a wide speed range (owing to electronic commutation)
- Continuous start-stop operation possible with high repeat frequencies (owing to electrical commutation)
- Easy attachment to the machine (owing to flange according to DIN 42948)
- Any installation position desired
- Direct overhung mounting of pinions and belt pulleys (owing to the bearing being designed for high radial loads)
- Easy cabling (owing to cable sets, available in various designs)
- Simple and quick startup (owing to data memory in the motor encoder unit)

Design and components MHD motors are permanent-magnet motors with electronic commutation. Special magnet materials permit the motors to be designed with low inertia masses. The following figure shows the principal design of MHD motors.

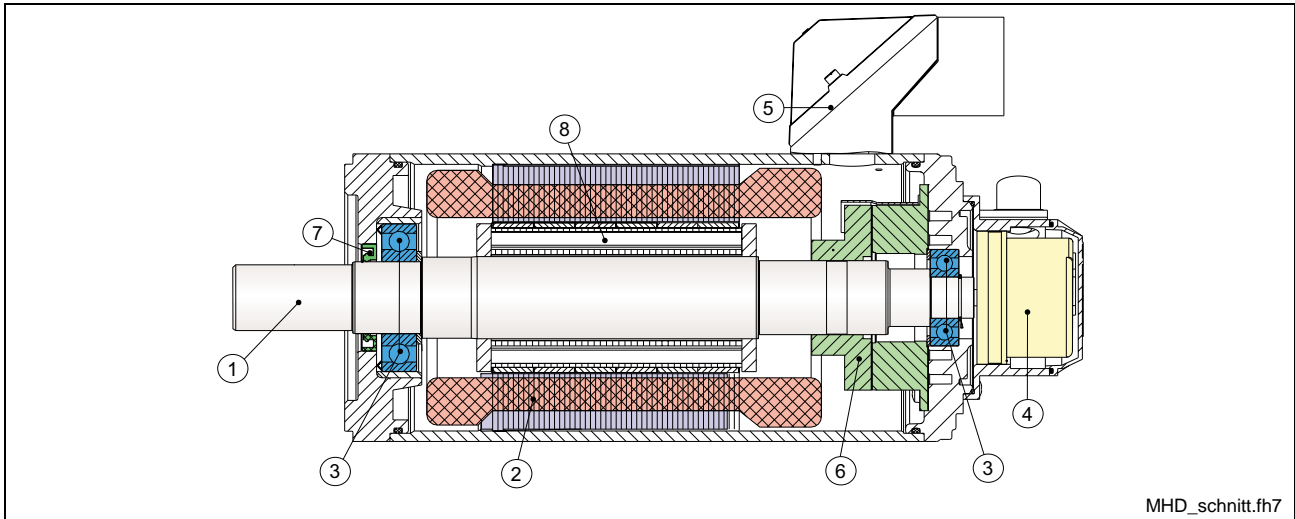

- (1): Shaft
- (2): Stator with winding
- (3): Bearing
- (4): Motor encoder
- (5): Flange socket (power connection)
- (6): Holding brake
- (7): Shaft sealing ring
- (8): Rotor with permanent magnets

Fig. 1-2: Design of MHD motors

MHD motors are available in various designs. Please refer to the chapter on type codes for more detailed information.

1.2 About this Documentation

Structure of this Document Edition

The present documentation contains safety regulations, technical data, and operating instructions for MHD motors. The chapters can be subdivided in the following focal points with regard to their contents:

Chapter	Title	Content
1	Introduction	General information
2	Important Instructions on Use	Safety
3	Safety notes	
4	MHD Type Code	
5	General Notes on Technical Data	Product description (for planners and machine constructors)
6	MHD041	
7	MHD071	
8	MHD090	
9	MHD093	
10	MHD095	
11	MHD112	
12	MHD115	
13	MHD131	
14	Accessories	
15	Connection System	
16	Notes Application	
17	Handling	
18	Assembly	Praxis (for operating and maintenance personnel)
19	Startup, Operation, and Maintenance	
20	Service and Support	
21	Appendix	General information
22	Index	

Fig. 1-3: Document structure

Modifications as Compared with the Predecessor Version

The following list shows the modifications as compared with the predecessor version DOK-MOTOR*-MHD*****-PR04 -EN-P

Where?	What?
Chapters 6-13	New: Specification of 100K values and characteristic curves; specification of ratings; addition of new motors
Chapters 9+12	New: Technical data about liquid coolant; addition
Chapter 15	New: Blower connection type (3)
Chapter 16	New: Application note about holding brake; revision
Appendix Chapter 20-2	New: Overview cross-section power conduction; update

Fig. 1-4: Modifications

Note: This list does not lay claim to completeness. The author reserves the right to neglect minor modifications in this list.

Additional documentation

Rexroth provides all product documentation on CD in a PDF-format. The documentation on CD as a whole is not necessary for projecting a device.

Note: All documentation on the CD are also available as printed version. You can order the necessary documentation over the concerned Rexroth branch.

Material no.:	Title / description
00281883	-Produktdokumentation Electric Drives and Controls Version <u>xx</u> DOK-GENRL-CONTR*DRIVE-GN <u>xx</u> -EN-D650
1) The index (e.g. ..00.06-...) identifies the version of the documentation.	

Fig. 1-5: Additional documentation

Note: If the present documentation contains references to advanced documentations, the version of the latter is always represented in bold and underlined type (e.g. **06**). If documentations are ordered, their version may be a higher one!

Standards

This documentation refers to German, European and international technical standards. Documents and sheets on standards are subject to the protection by copyright and may not be passed on to third parties by Rexroth Indramat. If necessary, please address the authorized sales outlets or, in Germany, directly to:

BEUTH Verlag GmbH

Burggrafenstrasse 6

10787 Berlin

Phone +49-(0)30-26 01-22 60, Fax +49-(0)30-26 01-12 60

Internet: <http://www.din.de/beuth>

E-mail: postmaster@beuth.de

Outside Systems

Documentation for external systems, which are connected to Rexroth Indramat components, are not included in the scope of delivery and must be ordered directly from the particular manufacturers.

Feedback

Your experiences are an essential part of the process of improving both product and documentation.

Please do not hesitate to inform us of any mistakes you detect in this documentation or of any modifications you might desire. We would appreciate your feedback.

Please send your remarks to:

Bosch Rexroth AG
Bgm.-Dr.-Nebel-Str. 2 • D-97816 Lohr a. Main • Dep. BRC/EDM2
Fax +49 (0) 93 52 / 40-43 80

2 Important Instructions on Use

2.1 Intended Use

Introduction

In their design and manufacture, the products by Bosch Rexroth reflect the latest state of technology. Before they are delivered, they are checked for their operationally safe state.

The products may only be used as intended. If they are not used as intended, situations may arise resulting in injuries to property and persons.

Note: For damage caused by products not being used as intended, Bosch Rexroth, as manufacturers, do not give any warranty, assume any liability, or pay any damages. Any risks resulting from the products not being used as intended are the sole responsibility of the user.

Before using the products by Bosch Rexroth, the following requirements must be fulfilled so as to ensure that they are used as intended:

- Anybody handling one of our products in any manner must read and understand the appropriate safety instructions and the intended use.
- If they are hardware components, the products concerned must be left in their original state, i.e. it is not permitted to modify them structurally. Software products may not be decompiled; their source codes may not be altered.
- Damaged or defective products may not be installed or put into operation.
- It must be ensured that the products are installed, operated and serviced according to the regulations and environmental conditions specified in the documentation.

Fields of Use and Application

AC servo motors of the MHD series by Rexroth are intended to be used as servo and main drive motors. The following are typical fields of application:

- Machine tools
- Printing and paper-processing machines
- Packaging and food-processing machines
- Automation and handling

Unit types with different driving powers and different interfaces are available for an application-specific use of the motors.

Controlling and monitoring of the motors may require connection of additional sensors and actuators.

Note: The motors may only be used with the accessories specified in the documentation. Components which are not expressly named may neither be mounted nor connected. The same applies to cables and lines.

The motors may be operated only in the expressly specified component configurations and combinations and with the software and firmware specified in the appropriate functional description.

Any connected drive controller must be programmed before startup, in order to ensure that the motor executes the functions specific to the particular application.

The motors may only be operated under the assembly, mounting and installation conditions, in the position of use, and under the environmental conditions (temperature, degree of protection, humidity, EMC, and the like) specified in this documentation.

2.2 Non-Intended Use

Any use of the motors outside of the fields of application mentioned above or under operating conditions and technical data other than those specified in this documentation is considered to be “non-intended use”.

MHD motors may not be used if . . .

- they are subjected to operating conditions which do not comply with the environmental conditions described above (e.g. operation under water, under extreme variations in temperature or extreme maximum temperatures is not permitted),
- the intended fields of application have not been expressly released for the motors by Rexroth. Please be absolutely sure to also observe the statements made in the general safety instructions.

3 Safety Instructions for Electric Drives and Controls

3.1 Introduction

Read these instructions before the initial startup of the equipment in order to eliminate the risk of bodily harm or material damage. Follow these safety instructions at all times.

Do not attempt to install or start up this equipment without first reading all documentation provided with the product. Read and understand these safety instructions and all user documentation of the equipment prior to working with the equipment at any time. If you do not have the user documentation for your equipment, contact your local Bosch Rexroth representative to send this documentation immediately to the person or persons responsible for the safe operation of this equipment.

If the equipment is resold, rented or transferred or passed on to others, then these safety instructions must be delivered with the equipment.



WARNING

Improper use of this equipment, failure to follow the safety instructions in this document or tampering with the product, including disabling of safety devices, may result in material damage, bodily harm, electric shock or even death!

3.2 Explanations

The safety instructions describe the following degrees of hazard seriousness in compliance with ANSI Z535. The degree of hazard seriousness informs about the consequences resulting from non-compliance with the safety instructions.

Warning symbol with signal word	Degree of hazard seriousness according to ANSI
 DANGER	Death or severe bodily harm will occur.
 WARNING	Death or severe bodily harm may occur.
 CAUTION	Bodily harm or material damage may occur.

Fig. 3-1: Hazard classification (according to ANSI Z535)

3.3 Hazards by Improper Use



DANGER

**High voltage and high discharge current!
Danger to life or severe bodily harm by electric shock!**



DANGER

Dangerous movements! Danger to life, severe bodily harm or material damage by unintentional motor movements!



WARNING

High electrical voltage due to wrong connections! Danger to life or bodily harm by electric shock!



WARNING

Health hazard for persons with heart pacemakers, metal implants and hearing aids in proximity to electrical equipment!



CAUTION

Surface of machine housing could be extremely hot! Danger of injury! Danger of burns!



CAUTION

Risk of injury due to improper handling! Bodily harm caused by crushing, shearing, cutting and mechanical shock or incorrect handling of pressurized systems!



CAUTION

Risk of injury due to incorrect handling of batteries!

3.4 General Information

- Bosch Rexroth AG is not liable for damages resulting from failure to observe the warnings provided in this documentation.
- Read the operating, maintenance and safety instructions in your language before starting up the machine. If you find that you cannot completely understand the documentation for your product, please ask your supplier to clarify.
- Proper and correct transport, storage, assembly and installation as well as care in operation and maintenance are prerequisites for optimal and safe operation of this equipment.
- Only persons who are trained and qualified for the use and operation of the equipment may work on this equipment or within its proximity.
 - The persons are qualified if they have sufficient knowledge of the assembly, installation and operation of the equipment as well as an understanding of all warnings and precautionary measures noted in these instructions.
 - Furthermore, they must be trained, instructed and qualified to switch electrical circuits and equipment on and off in accordance with technical safety regulations, to ground them and to mark them according to the requirements of safe work practices. They must have adequate safety equipment and be trained in first aid.
- Only use spare parts and accessories approved by the manufacturer.
- Follow all safety regulations and requirements for the specific application as practiced in the country of use.
- The equipment is designed for installation in industrial machinery.
- The ambient conditions given in the product documentation must be observed.
- Use only safety features and applications that are clearly and explicitly approved in the Project Planning Manual.

For example, the following areas of use are not permitted: construction cranes, elevators used for people or freight, devices and vehicles to transport people, medical applications, refinery plants, transport of hazardous goods, nuclear applications, applications sensitive to high frequency, mining, food processing, control of protection equipment (also in a machine).
- The information given in the documentation of the product with regard to the use of the delivered components contains only examples of applications and suggestions.

The machine and installation manufacturer must

 - make sure that the delivered components are suited for his individual application and check the information given in this documentation with regard to the use of the components,
 - make sure that his application complies with the applicable safety regulations and standards and carry out the required measures, modifications and complements.
- Startup of the delivered components is only permitted once it is sure that the machine or installation in which they are installed complies with the national regulations, safety specifications and standards of the application.

- Operation is only permitted if the national EMC regulations for the application are met.
The instructions for installation in accordance with EMC requirements can be found in the documentation "EMC in Drive and Control Systems".
The machine or installation manufacturer is responsible for compliance with the limiting values as prescribed in the national regulations.
- Technical data, connections and operational conditions are specified in the product documentation and must be followed at all times.

3.5 Protection Against Contact with Electrical Parts

Note: This section refers to equipment and drive components with voltages above 50 Volts.

Touching live parts with voltages of 50 Volts and more with bare hands or conductive tools or touching ungrounded housings can be dangerous and cause electric shock. In order to operate electrical equipment, certain parts must unavoidably have dangerous voltages applied to them.



DANGER

High electrical voltage! Danger to life, severe bodily harm by electric shock!

- = Only those trained and qualified to work with or on electrical equipment are permitted to operate, maintain or repair this equipment.
 - = Follow general construction and safety regulations when working on high voltage installations.
 - = Before switching on power the ground wire must be permanently connected to all electrical units according to the connection diagram.
 - = Do not operate electrical equipment at any time, even for brief measurements or tests, if the ground wire is not permanently connected to the points of the components provided for this purpose.
 - = Before working with electrical parts with voltage higher than 50 V, the equipment must be disconnected from the mains voltage or power supply. Make sure the equipment cannot be switched on again unintended.
 - = The following should be observed with electrical drive and filter components:
 - = Wait five (5) minutes after switching off power to allow capacitors to discharge before beginning to work. Measure the voltage on the capacitors before beginning to work to make sure that the equipment is safe to touch.
 - = Never touch the electrical connection points of a component while power is turned on.
 - = Install the covers and guards provided with the equipment properly before switching the equipment on. Prevent contact with live parts at any time.
 - = A residual-current-operated protective device (RCD) must not be used on electric drives! Indirect contact must be prevented by other means, for example, by an overcurrent protective device.
 - = Electrical components with exposed live parts and uncovered high voltage terminals must be installed in a protective housing, for example, in a control cabinet.
-

To be observed with electrical drive and filter components:



DANGER

**High electrical voltage on the housing!
High leakage current! Danger to life, danger of
injury by electric shock!**

- = Connect the electrical equipment, the housings of all electrical units and motors permanently with the safety conductor at the ground points before power is switched on. Look at the connection diagram. This is even necessary for brief tests.
- = Connect the safety conductor of the electrical equipment always permanently and firmly to the supply mains. Leakage current exceeds 3.5 mA in normal operation.
- = Use a copper conductor with at least 10 mm² cross section over its entire course for this safety conductor connection!
- = Prior to startups, even for brief tests, always connect the protective conductor or connect with ground wire. Otherwise, high voltages can occur on the housing that lead to electric shock.

3.6 Protection Against Electric Shock by Protective Low Voltage (PELV)

All connections and terminals with voltages between 0 and 50 Volts on Rexroth products are protective low voltages designed in accordance with international standards on electrical safety.



WARNING

**High electrical voltage due to wrong
connections! Danger to life, bodily harm by
electric shock!**

- = Only connect equipment, electrical components and cables of the protective low voltage type (PELV = Protective Extra Low Voltage) to all terminals and clamps with voltages of 0 to 50 Volts.
- = Only electrical circuits may be connected which are safely isolated against high voltage circuits. Safe isolation is achieved, for example, with an isolating transformer, an opto-electronic coupler or when battery-operated.

3.7 Protection Against Dangerous Movements

Dangerous movements can be caused by faulty control of the connected motors. Some common examples are:

- improper or wrong wiring of cable connections
- incorrect operation of the equipment components
- wrong input of parameters before operation
- malfunction of sensors, encoders and monitoring devices
- defective components
- software or firmware errors

Dangerous movements can occur immediately after equipment is switched on or even after an unspecified time of trouble-free operation.

The monitoring in the drive components will normally be sufficient to avoid faulty operation in the connected drives. Regarding personal safety, especially the danger of bodily injury and material damage, this alone cannot be relied upon to ensure complete safety. Until the integrated monitoring functions become effective, it must be assumed in any case that faulty drive movements will occur. The extent of faulty drive movements depends upon the type of control and the state of operation.

**DANGER****Dangerous movements! Danger to life, risk of injury, severe bodily harm or material damage!**

- = Ensure personal safety by means of qualified and tested higher-level monitoring devices or measures integrated in the installation. Unintended machine motion is possible if monitoring devices are disabled, bypassed or not activated.
 - = Pay attention to unintended machine motion or other malfunction in any mode of operation.

 - = Keep free and clear of the machine's range of motion and moving parts. Possible measures to prevent people from accidentally entering the machine's range of motion:
 - use safety fences
 - use safety guards
 - use protective coverings
 - install light curtains or light barriers
 - = Fences and coverings must be strong enough to resist maximum possible momentum, especially if there is a possibility of loose parts flying off.
 - = Mount the emergency stop switch in the immediate reach of the operator. Verify that the emergency stop works before startup. Don't operate the machine if the emergency stop is not working.
 - = Isolate the drive power connection by means of an emergency stop circuit or use a starting lockout to prevent unintentional start.
 - = Make sure that the drives are brought to a safe standstill before accessing or entering the danger zone. Safe standstill can be achieved by switching off the power supply contactor or by safe mechanical locking of moving parts.
 - = Secure vertical axes against falling or dropping after switching off the motor power by, for example:
 - mechanically securing the vertical axes
 - adding an external braking/ arrester/ clamping mechanism
 - ensuring sufficient equilibration of the vertical axes
- The standard equipment motor brake or an external brake controlled directly by the drive controller are not sufficient to guarantee personal safety!

- = Disconnect electrical power to the equipment using a master switch and secure the switch against reconnection for:
 - maintenance and repair work
 - cleaning of equipment
 - long periods of discontinued equipment use
 - = Prevent the operation of high-frequency, remote control and radio equipment near electronics circuits and supply leads. If the use of such equipment cannot be avoided, verify the system and the installation for possible malfunctions in all possible positions of normal use before initial startup. If necessary, perform a special electromagnetic compatibility (EMC) test on the installation.
-

3.8 Protection Against Magnetic and Electromagnetic Fields During Operation and Mounting

Magnetic and electromagnetic fields generated near current-carrying conductors and permanent magnets in motors represent a serious health hazard to persons with heart pacemakers, metal implants and hearing aids.



WARNING

Health hazard for persons with heart pacemakers, metal implants and hearing aids in proximity to electrical equipment!

- = Persons with heart pacemakers, hearing aids and metal implants are not permitted to enter the following areas:
 - Areas in which electrical equipment and parts are mounted, being operated or started up.
 - Areas in which parts of motors with permanent magnets are being stored, operated, repaired or mounted.
 - = If it is necessary for a person with a heart pacemaker to enter such an area, then a doctor must be consulted prior to doing so. Heart pacemakers that are already implanted or will be implanted in the future, have a considerable variation in their electrical noise immunity. Therefore there are no rules with general validity.
 - = Persons with hearing aids, metal implants or metal pieces must consult a doctor before they enter the areas described above. Otherwise, health hazards will occur.
-

3.9 Protection Against Contact with Hot Parts



CAUTION

Housing surfaces could be extremely hot! Danger of injury! Danger of burns!

- = Do not touch housing surfaces near sources of heat! Danger of burns!
- ⇒ After switching the equipment off, wait at least ten (10) minutes to allow it to cool down before touching it.
- = Do not touch hot parts of the equipment, such as housings with integrated heat sinks and resistors. Danger of burns!

3.10 Protection During Handling and Mounting

Under certain conditions, incorrect handling and mounting of parts and components may cause injuries.



CAUTION

Risk of injury by incorrect handling! Bodily harm caused by crushing, shearing, cutting and mechanical shock!

- = Observe general installation and safety instructions with regard to handling and mounting.
- ⇒ Use appropriate mounting and transport equipment.
- ⇒ Take precautions to avoid pinching and crushing.
- = Use only appropriate tools. If specified by the product documentation, special tools must be used.
- ⇒ Use lifting devices and tools correctly and safely.
- = For safe protection wear appropriate protective clothing, e.g. safety glasses, safety shoes and safety gloves.
- ⇒ Never stand under suspended loads.
- = Clean up liquids from the floor immediately to prevent slipping.

3.11 Battery Safety

Batteries contain reactive chemicals in a solid housing. Inappropriate handling may result in injuries or material damage.



Risk of injury by incorrect handling!

- = Do not attempt to reactivate discharged batteries by heating or other methods (danger of explosion and cauterization).
- = Never charge non-chargeable batteries (danger of leakage and explosion).
- ⇒ Never throw batteries into a fire.
- ⇒ Do not dismantle batteries.
- = Do not damage electrical components installed in the equipment.

Note: Be aware of environmental protection and disposal! The batteries contained in the product should be considered as hazardous material for land, air and sea transport in the sense of the legal requirements (danger of explosion). Dispose batteries separately from other waste. Observe the legal requirements in the country of installation.

3.12 Protection Against Pressurized Systems

Certain motors and drive controllers, corresponding to the information in the respective Project Planning Manual, must be provided with pressurized media, such as compressed air, hydraulic oil, cooling fluid and cooling lubricant supplied by external systems. Incorrect handling of the supply and connections of pressurized systems can lead to injuries or accidents. In these cases, improper handling of external supply systems, supply lines or connections can cause injuries or material damage.



Danger of injury by incorrect handling of pressurized systems !

- = Do not attempt to disassemble, to open or to cut a pressurized system (danger of explosion).
- = Observe the operation instructions of the respective manufacturer.
- = Before disassembling pressurized systems, release pressure and drain off the fluid or gas.
- = Use suitable protective clothing (for example safety glasses, safety shoes and safety gloves)
- = Remove any fluid that has leaked out onto the floor immediately.

Note: Environmental protection and disposal! The media used in the operation of the pressurized system equipment may not be environmentally compatible. Media that are damaging the environment must be disposed separately from normal waste. Observe the legal requirements in the country of installation.

Notes

4 MHD Type Code

Each order of a product by Rexroth must be based on the type code. All available motor versions are uniquely described by their type code. The following figure describes the individual characters of the type code (abbrev. column) and their meaning.

Abbrev. column	1	2	3	4	5	6	7	8	9	1	2	3	4	5	6	7	8	9	2	0	1	2	3	4	5	6	7	8	9	3	0	1	2	3	4	5	6	7	8	9	4			
Example:	M	H	D	1	1	2	C	-	0	2	4	-	N	G	0	-	A	N																										

- 1. Product group**
 - 1.1 MHD..... = MHD

- 2. Motor frame size**
 - 2.1 112..... = 112

- 3. Motor frame length^①**
 - 3.1 Frame lengths..... = A, B, C, D

- 4. Winding code**
 - 4.1 024..... = 024
 - 4.2 027..... = 027
 - 4.3 035..... = 035
 - 4.4 048..... = 048
 - 4.5 058..... = 058

- 5. Motor feedback**
 - 5.1 Digital servo feedback..... = N
 - 5.2 Digital servo feedback with integrated multiturn absolute encoder..... = P

- 6. Output shaft**
 - 6.1 Plain shaft (with shaft sealing ring)..... = G
 - 6.2 Shaft with keyway according to DIN 6885-1 (with shaft sealing ring)..... = P

- 7. Holding brake^②**
 - 7.1 Without holding brake..... = 0
 - 7.2 22,0 Nm holding brake..... = 1
 - 7.3 70,0 Nm holding brake..... = 3

- 8. Output direction of power connector^③**
 - 8.1 Connector to side A..... = A
 - 8.2 Connector to side B..... = B
 - 8.3 Connector to the left..... = L
 - 8.4 Connector to the right..... = R

- 9. Housing type^④**
 - 9.1 Natural convection..... = N

- 10. Reference to standards**

Standard	Title	Version
DIN 6885-1	Drive Type Fastenings without Taper Action; Parallel Keys, Keyways, Deep Pattern	08.1968

Note:

① Motor frame lengths "A" and "C" available only with winding code "024", "035" and "058"
 Motor frame length "B" available only with winding code "024", "035", "048" and "058"
 Motor frame length "D" available only with winding code "027"

② Holding brake "1" available only with motor frame lengths "A" and "B"
 Holding brake "3" available only with motor frame lengths "C" and "D"

③ Output shaft viewed from the front (see figure 1)

④ Housing type "N" suitable for natural convection and surface ventilation

Example illustrated: MHD112

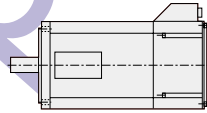

Position of power connector = on top

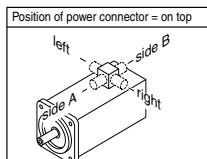

Figure 1

BspTypeMHD.tn10

Fig. 4-1: MHD type code (example)

Note: When selecting a product, always consider the detailed specifications and instructions in the chapters entitled "Technical Data" and "Application Instructions".

- The sections below are numbered according to the numbering of the individual type codes (see chapter "Technical Data").

1. Product Group

Abbrev. column **1 2 3** MHD Three-digit Bosch Rexroth-specific designation of a servo motors series.

2. Motor Frame Size

Abbrev. column **4 5 6** The motor frame size defines essential mechanical motor dimensions. The following table assigns essential motor dimensions to the motor frame sizes.

Motor frame size	Description / details	
	Flange size in mm	Centering diameter in mm
041	82	50
071	115	95
090	140	110
093	140 / 150	130
095	140 / 150	130
112	192	130
115	192	180
131	260	250

Fig. 4-2: MHD motor frame sizes

3. Motor Frame Length

Abbrev. column **7** Within the scope of a motor frame size, the motor frame length defines the various continuous torques at standstill. The continuous torques at standstill of the MHD motors are listed in the table below. The values specified are applicable to the "natural convection" mode.

Motor frame length	Motor Frame Size							
	041	071	090	093	095	112	115	131
A	1.3 Nm	3.5 Nm	--	12.0 Nm	12.0 Nm	15.0 Nm	32.0 Nm	--
B	2.7 Nm	8.0 Nm	12.0 Nm	17.5 Nm	17.5 Nm	28.0 Nm	50.0 Nm	48.0 Nm
C	--	--	--	23.0 Nm	23.0 Nm	38.0 Nm	70.0 Nm	--
D	--	--	--	--	--	48.0 Nm	--	160 Nm

Fig. 4-3: MHD motor frame lengths

4. Winding Code

Abbrev. column **9** **10** **11**

In connection with the motor frame size and motor frame length, the winding codes define the electric motor output data for all Bosch Rexroth motors.

The type code specifies all possible winding codes, which are available for a motor frame size / length.

Example

Motor frame size / length	Available winding codes
MHD112B	024, 035, 048, 058

Fig. 4-4: Winding code example

In chapters 6 to 13, the technical data and the speed-torque curves are specified for all motors.

5. Motor encoder

Abbrev. column **13**

MHD motors are equipped with an integrated encoder system (motor feedback). To control the motor speed and/or to position the motor, the drive controller requires information on the current motor position.

To achieve this, the integrated encoder system (motor encoder) makes the appropriate signals available to the drive controller.

The following options are available:

Option	Type	Type of position detection
N	Digital servo feedback (HSF)	Relative
P	Digital servo feedback (HSF with integrated multiturn absolute encoder)	Absolute (more than 4096 revolutions)

Fig. 4-5: MHD motor encoder

6. Output Shaft

Abbrev. column **14**

To connect the machine elements to be driven to the motor shafts, the following options are available for MHD motors.

Option	Design	Detail
G	Plain shaft	With end-sided centering hole with "DS" thread according to DIN 332, Part 2, Edition 05.83
P	Shaft with keyway ¹⁾	
1) Keyway according to DIN 6885, Sheet 1, ed. 08.68. For details, refer to the motor rating sheet!		

Fig. 4-6: MHD output shafts

Note: MHD motors are balanced with the **complete** featherkey. The pertinent featherkey is not included in the scope of delivery.

7. Holding Brake

Abbrev. column **15**

Optional. Required for clamping the servo axis when the machine is in the de-energized state.

Option	Holding Brakes	
0	Without holding brake	
1, 3	With holding brake	Please refer to the motor type codes for the holding torques.

Fig. 4-7: MHD holding brakes

The holding brake is operated according to the “electrically releasing” principle. In the de-energized state, a magnetic force acts upon the brake armature disk. This causes the brake to close and to hold the axis.

By applying 24 VDC ($\pm 10\%$), the permanent magnetic field is compensated by the electrically generated magnetic field: the brake opens.

Note: Please also observe the installation and safety instructions on the motor holding brakes in the chapter entitled “Application Instructions”.

8. Output Direction of Power Connector

Abbrev. column **17**
Definition of cable output direction

The possible cable output directions for Bosch Rexroth motors are defined as follows. The following is applicable (view on the output shaft):

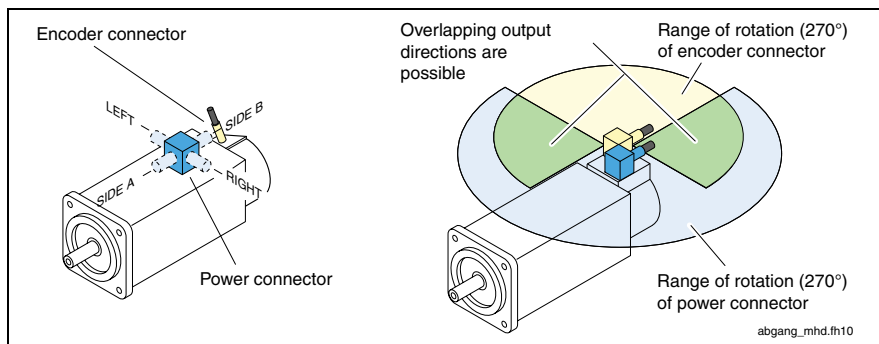

Fig. 4-8: Definition of cable output directions

Option	Output direction	Available for the motors below
A	Output connector in direction of side A	MHD093
B	Output connector in direction of side B	MHD095
L	Power connector to the left	MHD112
R	Power connector to the right	MHD115
U	Power and feedback connectors turnable within a range of 270°	MHD131
		MHD041
		MHD071
		MHD090

Fig. 4-9: MHD cable output directions

Supplied Condition MHD motors are delivered according to the option specified in the order.

Note: The cable output direction can be changed during assembly (see Chapter 18).

9. Housing Type

Abbrev. column 18 Depending on the type of motor cooling, Rexroth delivers different motor housings.

Option	Housing type	For the modes below
A	For natural convection	Natural convection Surface cooled
N	For liquid cooling	Natural convection ¹⁾ Liquid cooled
1) The housing type "A" should preferably be used for the "natural convection" mode.		

Fig. 4-10: MHD housing type

10. Reference to Standards

The item "reference to standards" indicates standards referred to in the type code (e.g. DIN, EN, ISO, etc.) or also applicable factory standards (INN . . .). The version listed is always that valid at the time of type code issuing.

Remark

Please refer to this item for additionally required information concerning the handling of the type code. This includes, e.g, descriptions on footnotes, notes on availability, or exclusion clauses.

5 General Notes on Technical Data

5.1 60-K and 100-K Parameters

The speed-torque curves and the technical data are specified for two different motor overtemperatures.

These are:

- 60 K housing overtemperature and
- 100 K winding temperature

Note: When selecting the technical data, observe the temperatures specified! The appropriate parameters are identified by **100 K** or **60 K**.

Structure and measurement of the 60-K characteristic curve

The motor data and characteristic curves are determined using MHD motors under the following conditions:

- Insulated structure (aluminum flange)
- Permissible housing overtemperature $\Delta T = 60$ K
- If motors with the optional holding brake are concerned, the data are always specified for motors **with** holding brake.
- Motors with radial shaft sealing ring

Structure and measurement of the 100-K characteristic curve

The motor data and characteristic curves are determined using MHD motors under the following conditions:

- Structure **not** insulated (attachment to steel flange, LxWxH 450x30x350 in size; LxWxH 120x40x100 in case of the MHD041)
- Permissible winding overtemperature $\Delta T = 100$ K
- If motors with the optional holding brake are concerned, the data are always specified for motors **with** holding brake.
- Motors with radial shaft sealing ring

Note: The machine accuracy can be negatively affected by an increased linear expansion during 100-K operation. We recommend to use 60-K data when projecting systems.

5.2 Operating Modes

Bosch Rexroth motors are documented according to the test criteria and measuring methods of EN 60034-1. The characteristic curves specified correspond to the operating modes S1 or S6.

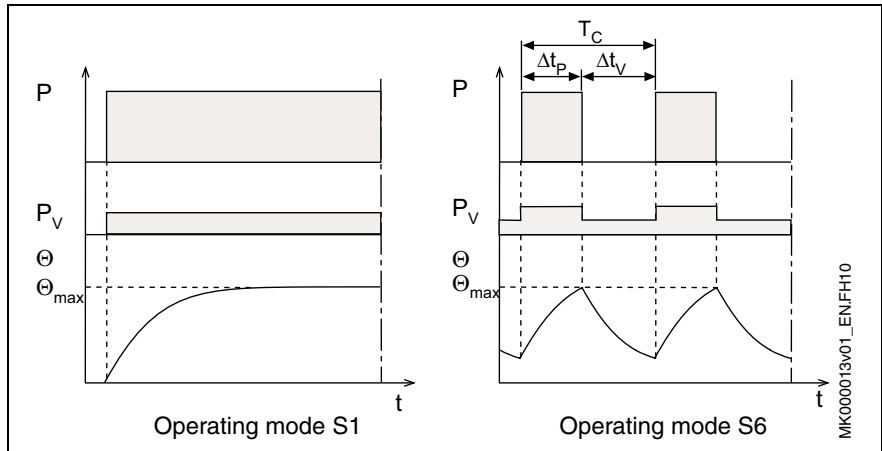

- P: Load
- P_V: Electric losses
- Θ: Temperature
- Θ_{max}: Highest temperature (motor housing)
- t: Time
- T_C: Cycle duration
- Δt_P: Operating time with constant load
- Δt_V: Idle time

Fig. 5-1: Operating modes according to EN 60034-1: 1998

ON time

The operating mode S6 is supplemented by specification of the ON time (ED) in %. The ON time is calculated with the following formula:

$$ED = \frac{\Delta t_P}{T_C} \cdot 100\%$$

- ED: Cyclic duration factor in %
- T_C: Cycle duration
- Δt_P: Operating time with constant load

Fig. 5-2: Cyclic duration factor

The values specified in the documentation have been determined on the basis of the following parameters:

- Cycle duration: 15 min
- Cyclic duration factor (ED): 25%

Note: If applicable, conditions deviating therefrom are marked accordingly.

5.3 Definition of Parameters

Electric parameters

Characteristic motor speed n_K	With a DC link voltage of 540 V _{DC} and at the characteristic speed, the continuous torque that can be output is approx. ½ continuous torque at standstill.
Continuous torque at standstill M_{dN}	The continuous torque that can be output at the motor output shaft at a speed of $n = 0$.
Continuous current at standstill I_{dN}	Phase current (crest value) of the motor required for the continuous torque at standstill M_{dN} at a speed of $n = 0$.
Peak current I_{max}	Maximum, briefly permissible phase current (crest value) of the motor without adverse affect on the permanent magnet circuit of the motor.
Torque constant at 20 °C K_M	Ratio of the increase in torque to the motor phase current (crest value) at a motor temperature of 20 °C. Unit: (Nm/A). Applicable up to approx. $i = 2 \times I_{dN}$.
Voltage constant at 20 °C $K_{E(eff)}$	Root-mean-square value of the induced motor voltage at a motor temperature of 20 °C and 1000 revolutions per minute. Unit: (V/1000 min ⁻¹).
Winding resistance at 20 °C R_{12}	Winding resistance measured between two phases in ohms (Ω).
Winding inductivity L_{12}	Inductivity measured between two phases in (mH).
Number of pole pairs p	Number of pole pairs of the motor.
Rated speed n_N	Typical useful speed defined by the manufacturer. Depending on the particular application, other useful speeds are possible (see speed-torque curve).
Rated torque M_N	Continuous torque that can be output at the rated speed in operating mode S1.
Rated current $I_{N(eff)}$	Phase current of the motor at the rated speed and load with rated torque, specified as root-mean-square value.
Rated output P_N	Power consumption of the motor at the rated speed and load with rated torque, specified in kilowatts (kW).
Rated voltage $U_{N(eff)}$	Root-mean-square value of the voltage to be applied to the motor, with the motor loaded with the rated torque and the rated speed. Unit (V).
Rated frequency f_N	Frequency of the rated voltage at rated speed (Hz).

Mechanical parameters

Maximum speed n_{\max} Maximum permissible speed of the motor. Limiting factors can have mechanical (centrifugal forces, bearing stress) or electrical (DC link voltage) causes.

Theoretical maximum torque M_{\max} Maximum torque that can be output for approx. 400 ms at a peak current of I_{\max} (guaranteed value which, owing to production tolerances, may be higher by 20%). The achievable maximum torque depends on the drive controller used. Only the maximum torques M_{\max} specified in the selection lists for the motor-controller combination are binding.

Moment of inertia of the rotor J_M Moment of inertia of the rotor without the optional holding brake. Unit (kgm^2).

Mass m_M Motor mass without the optional holding brake and optional motor blower, specified in kg.

Thermal time constant T_{th} Time of the temperature rise to 63% of the final temperature of the motor housing with the motor loaded with the permissible S1 continuous torque. The thermal time constant is defined by the type of cooling used.

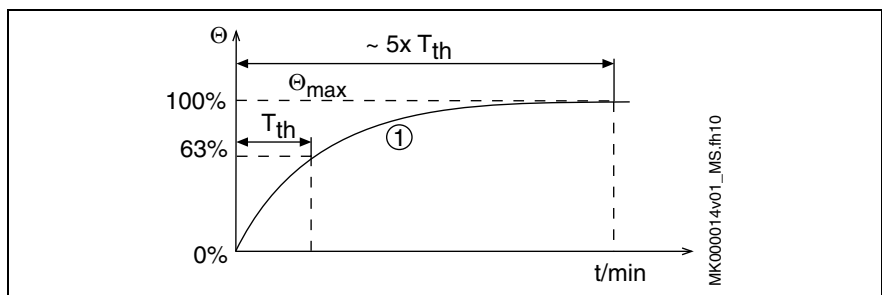

(1): Course of the motor housing temperature over time

Θ_{\max} : Highest temperature (motor housing)

T_{th} : Thermal time constant

Fig. 5-3: Thermal time constant

5.4 Sample Curve

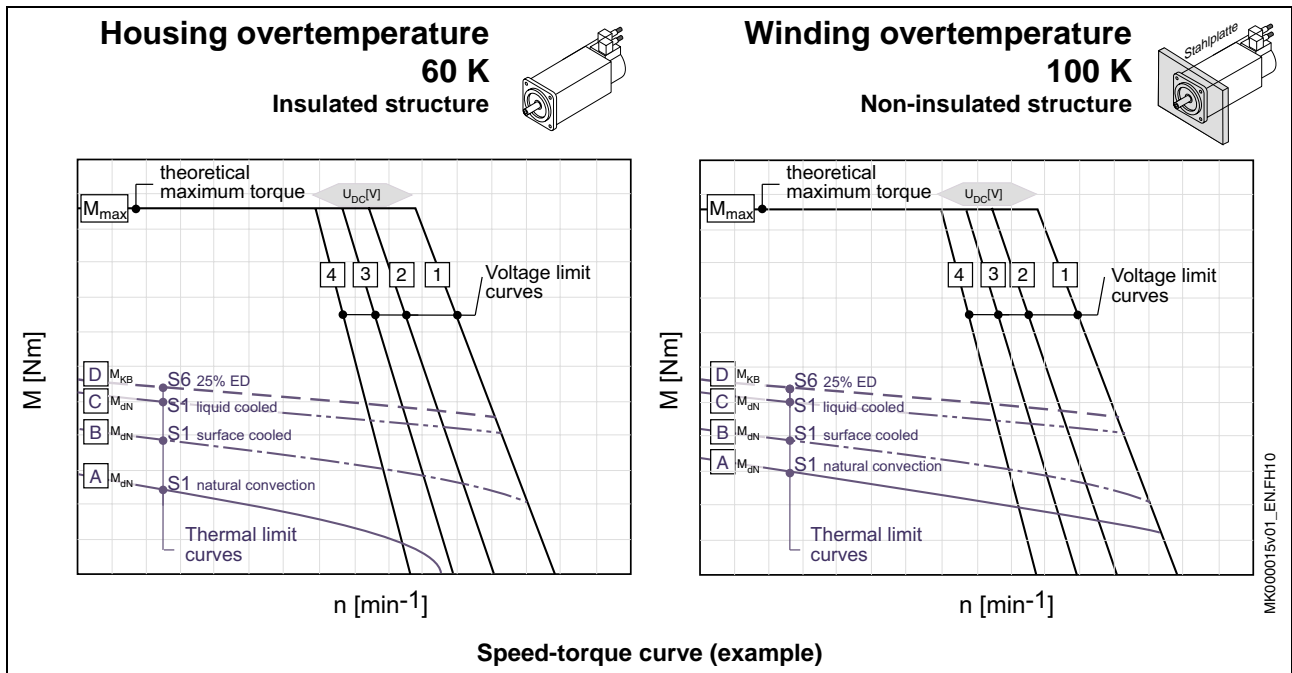

- [A]-[D]: Thermal limit curves**
- [A]: **M_{dN}** S1 continuous operation curve of the motor (according to EN 60034-1; 1998), natural convection
 - [B]: **M_{dN}** S1 continuous operation curve of the motor (according to EN 60034-1; 1998), surface cooling
 - [C]: **M_{dN}** S1 continuous operation curve of the motor (according to EN 60034-1; 1998), liquid cooling
 - [D]: **M_{KB}** S6 intermittent operation curve with a motor ON time of 25% (according to EN 60034-1; 1998). The maximum cycle duration is 15 min.
- [M_{max}]:** Corresponds to the theoretically possible maximum torque of the motor. The value can be limited by the drive controller.
- [1]-[4]: Characteristic voltage limit curves.** When a speed at the safe commutation limit is reached, the voltage limit curve limits the available maximum torque **M_{max}**. The maximum motor speed is determined by the DC link voltage used. There are separate characteristic curves for the various drive controllers in connection with the power supply unit and the supply voltage used.
- [1]: HDS to HVR
 - [2]: HDS to HVE or DKCxx.3 with a power connection of 3 x AC 480 V
 - [3]: HDS to HVE or DKCxx.3 with a power connection of 3 x AC 440 V
 - [4]: HDS to HVE or DKCxx.3 with a power connection of 3 x AC 400 V

Fig. 5-4: Sample curves

6 MHD041

6.1 Technical data

Description	Symbol	Unit	MHD041A-144			
			Natural 60K	Natural 100 K	Surface 60 K/100	Liquid 60 K/100
Type of cooling			Natural 60K	Natural 100 K	Surface 60 K/100	Liquid 60 K/100
Motor overtemperature						
Electric parameters						
Characteristic motor speed	n_K	min^{-1}	7000			
Continuous torque at standstill	M_{dN}	Nm	1.3	1.35	not	not
Continuous current at standstill	I_{dN}	A	3.5	3.6	available	available
Peak current	I_{max}	A	15.8			
Torque constant at 20 °C ¹⁾	K_m	Nm/A	0.42			
Voltage constant at 20 °C	$K_{E(eff)}$	V/1000min ⁻¹	38.2			
Winding resistance at 20 °C	R12	Ω	7.0			
Winding inductivity	L12	mH	13.5			
Number of pole pairs	p		3			
Rated data ²⁾						
Rated speed	n_N	min^{-1}	4000	4000		
Rated torque	M_N	Nm	0.68	0.89		
Rated current	I_N	A	1.29	1.68	not	not
Rated performance	P_N	kW	0.36	0.48	available	available
Rated voltage	U_N	V	163	165		
Rated frequency	f_N	Hz	200	200		
Mechanical parameters						
Moment of inertia of the rotor	J_M	kgm^2	0.88×10^{-4}			
Theoretical maximum torque	M_{max}	Nm	5.6			
Minimum strand cross-section ⁴⁾	S	mm^2	1.0	1.0	not	not
time constant	T_{th}	min	20	20	lieferbar	lieferbar
Maximum speed	n_{max}	min^{-1}	7500			
Motor mass ^{3) 5)}	m	kg	2.9			
Perm. stor. a. transport temperature	T_L	°C	-20 to +80			
Permissible ambient temperature ⁶⁾	T_{um}	°C	0 to 40			
Maximum setup height ⁶⁾	h	m	1000 above MSL			
Degree of protection ⁷⁾			IP65			
Insulation class (according to DIN VDE 0530 Part 1)			F			
Housing varnish			Prime coat black in a/w RAL 9005			
¹⁾ K_m is to be used for calculations with crest values (I_{dN} , I_{max}). For calculations with root-mean-square values (rated data), the torque constant K_m must be multiplied by a factor of $\sqrt{2}$. ²⁾ Values determined according to EN 60034-1. Current and voltage specified as root-mean-square values. ³⁾ Without holding brake. ⁴⁾ Applicable to Bosch Rexroth cables. Rated according to VDE0298-4 (1992) and installation type B2 according to EN 60204-1 (1993) at an ambient temperature of 40 °C. ⁵⁾ Without fan unit. ⁶⁾ If the limits specified are exceeded, the performance data must be reduced if necessary. For reduction factors, refer to the chapter entitled "Environmental Conditions". ⁷⁾ Provided the power and encoder cables are mounted properly.						

Fig. 6-1: Technical data of MHD041A-144

Description	Symbol	Unit	MHD041B-144			
Type of cooling			Natural	Natural	Surface	Liquid
Motor overtemperature			60K	100 K	60 K/100	60 K/100
Electric parameters						
Characteristic motor speed	n_K	min^{-1}	6000			
Continuous torque at standstill	M_{dN}	Nm	2.7	2.9	not	not
Continuous current at standstill	I_{dN}	A	7.5	8.2	available	available
Peak current	I_{max}	A	34.0			
Torque constant at 20 °C ¹⁾	K_m	Nm/A	0.4			
Voltage constant at 20 °C	$K_{E(\text{eff})}$	V/1000min ⁻¹	36.3			
Winding resistance at 20 °C	R12	Ω	1.8			
Winding inductivity	L12	mH	4.9			
Number of pole pairs	p		3			
Rated data ²⁾						
Rated speed	n_N	min^{-1}	3000	4500		
Rated torque	M_N	Nm	1.4	1.5		
Rated current	I_N	A	2.8	3.0	not	not
Rated performance	P_N	kW	0.52	0.88	available	available
Rated voltage	U_N	V	115	170		
Rated frequency	f_N	Hz	150	225		
Mechanical parameters						
Moment of inertia of the rotor	J_M	kgm^2	1.7×10^{-4}			
Theoretical maximum torque	M_{max}	Nm	11.3			
Minimum strand cross-section ⁴⁾	S	mm^2	1.0	1.0	not	not
time constant	T_{th}	min	30	30	lieferbar	lieferbar
Maximum speed	n_{max}	min^{-1}	7500			
Motor mass ^{3) 5)}	m	kg	4.5			
Perm. stor. a. transport temperature	T_L	°C	-20 to +80			
Permissible ambient temperature ⁶⁾	T_{um}	°C	0 to 40			
Maximum setup height ⁶⁾	h	m	1000 above MSL			
Degree of protection ⁷⁾			IP65			
Insulation class (according to DIN VDE 0530 Part 1)			F			
Housing varnish			Prime coat black in a/w RAL 9005			
¹⁾ K_m is to be used for calculations with crest values (I_{dN} , I_{max}). For calculations with root-mean-square values (rated data), the torque constant K_m must be multiplied by a factor of $\sqrt{2}$. ²⁾ Values determined according to EN 60034-1. Current and voltage specified as root-mean-square values. ³⁾ Without holding brake. ⁴⁾ Applicable to Bosch Rexroth cables. Rated according to VDE0298-4 (1992) and installation type B2 according to EN 60204-1 (1993) at an ambient temperature of 40 °C. ⁵⁾ Without fan unit. ⁶⁾ If the limits specified are exceeded, the performance data must be reduced if necessary. For reduction factors, refer to the chapter entitled "Environmental Conditions". ⁷⁾ Provided the power and encoder cables are mounted properly.						

Fig. 6-2: Technical data of MHD041B-144

Holding brake

Description	Symbol	Unit	Holding brake data
Motor type			MHD041B
Holding torque	M_4	Nm	2.2
Rated voltage	U_N	V	DC 24 \pm 10%
Rated current	I_N	A	0.34
Moment of inertia	J_B	Kgm ²	0.1 x 10 ⁻⁴
Connection time	t_1	ms	14
Disconnection time	t_2	ms	28
Mass	m_B	kg	0.23

Fig. 6-3: Technical data of MHD041B holding brake (optional)

Note: Motors of size MHD041A are only available without holding brake.

6.2 Type Code – Ordering Name

Abbrev. Column →	1	2	3	4	5	6	7	8	9	0	1	2	3	4	5	6	7	8	9	0	1	2	3	4	5	6	7	8	9	0	
Example:	M	H	D	0	4	1	B	-	1	4	4	-	N	G	0	-	U	N													

- 1. Product**
 - 1.1 MHD..... = MHD

- 2. Motor size**
 - 2.1 041..... = 041

- 3. Motor length**
 - 3.1 Lengths = A, B

- 4. Windings code**
 - 4.1 144 = 144

- 5. Motor encoder**
 - 5.1 digital servo feedback = N
 - 5.2 digital servo feedback with integrated multiturn absolute encoder = P

- 6. Driven shaft**
 - 6.1 plain shaft (with shaft sealing ring) = G
 - 6.2 shaft with key per DIN 6885-1 (with shaft sealing ring) = P

- 7. Holding brake**
 - 7.1 without holding brake = 0
 - 7.2 holding brake 2.2 Nm = 1 ①

- 8. Output direction of power connection**
 - 8.1 Connector turnable 270° = U

- 9. Housing design**
 - 9.1 for natural convection = N
 - 9.2 for natural convection with protection mode "IP68" = P ②

- 10. Standard reference**

Standard	Title	Edition
DIN 6885-1	Drive Type with Fastenings without Taper Action; Parallel Keys, Keyways, Deep Pattern	1968-08
DIN EN 60529	Degrees of protection provided by enclosures (IP code) (IEC 60529:1989 + A1:1999); German version EN 60529:1991 + A1:2000	2000-09

Note:

- ① Holding brake "1" is only available with motor length "B"
- ② Housing design "P" is only available with motor length "B"

t_mhd041_M06en.fh10

Fig. 6-4: MDH041 type code

6.3 Speed-Torque Curves

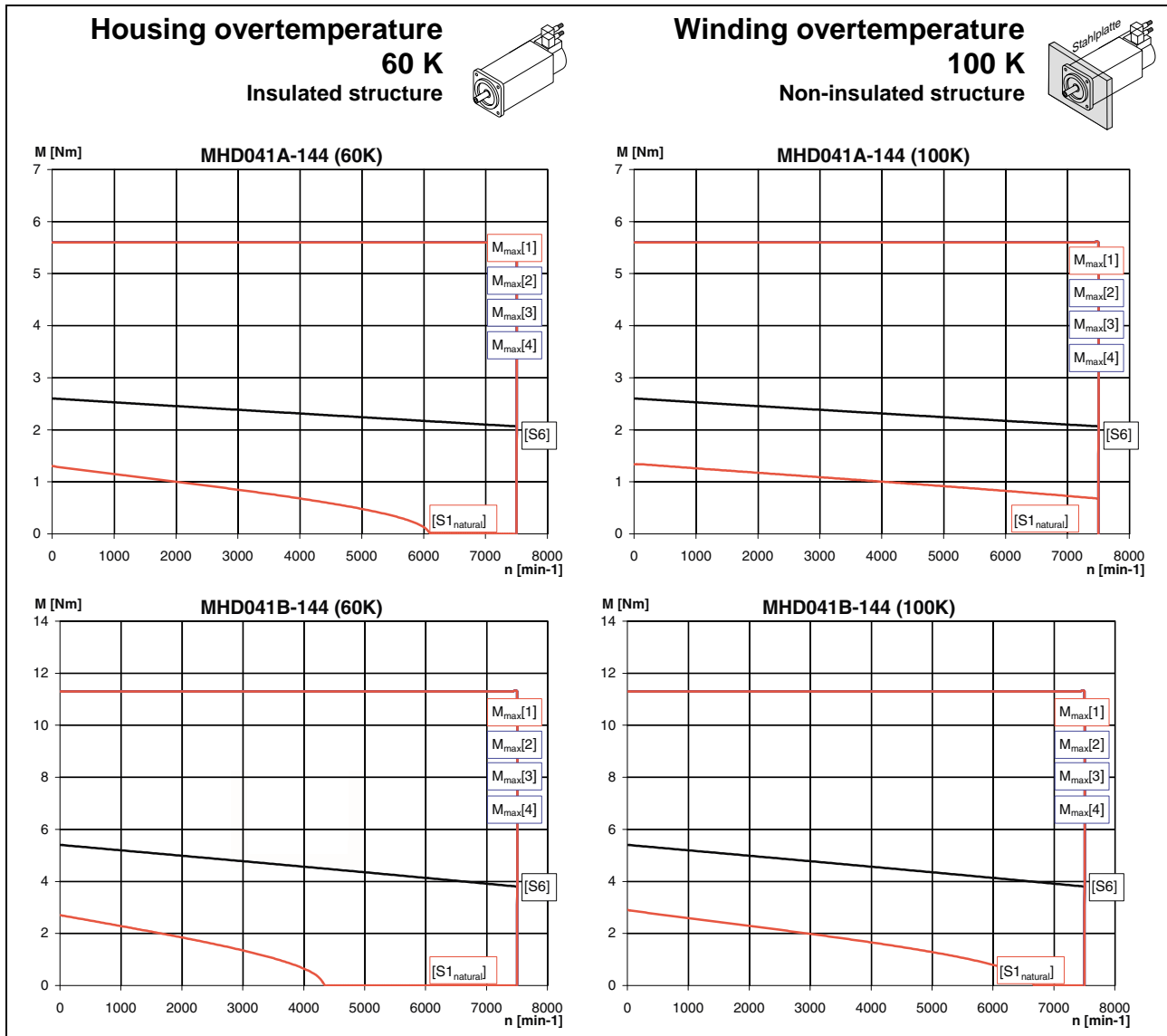

[S1_{natural}]: M_{dN} Natural conv. (S1 continuous operation)

[S6]: M_{KB} (S6 intermittent operation)

M_{max}[1]: HDS to HVR

M_{max}[2]: HDS to HVE or DKCxx.3 with a power connection of 3 x AC 480 V

M_{max}[3]: HDS to HVE or DKCxx.3 with a power connection of 3 x AC 440 V

M_{max}[4]: HDS to HVE or DKCxx.3 with a power connection of 3 x AC 400 V

Fig. 6-5: Characteristic curves

6.4 Shaft loads

Permissible maximum radial force $F_{\text{radial_max}}$ and permissible radial force F_{radial}

For explanations refer to Chapter 16.

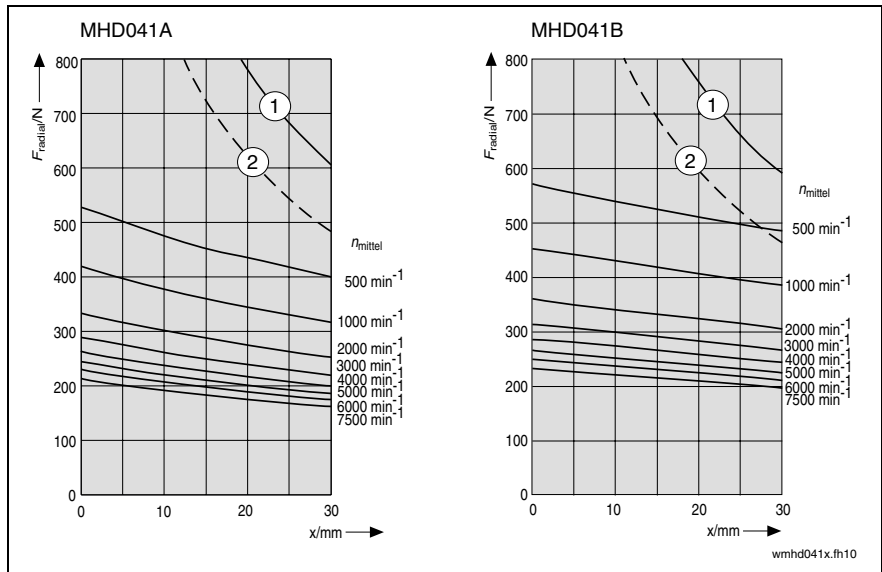

- (1): $F_{\text{radial_max}}$ (plain shaft)
- (2): $F_{\text{radial_max}}$ (shaft with keyway)

Fig. 6-6: MHD041: Permissible maximum radial force $F_{\text{radial_max}}$ and permissible radial force F_{radial}

Permissible axial force F_{axial}

$$F_{\text{axial}} = x \cdot F_{\text{radial}}$$

- x: 0.49 for MHD041A
- 0.45 for MHD041B

- F_{axial} : permissible axial force in N
- F_{radial} : permissible radial force in N

Fig. 6-7: MHD041: permissible axial force F_{axial}

6.5 Dimensional Details

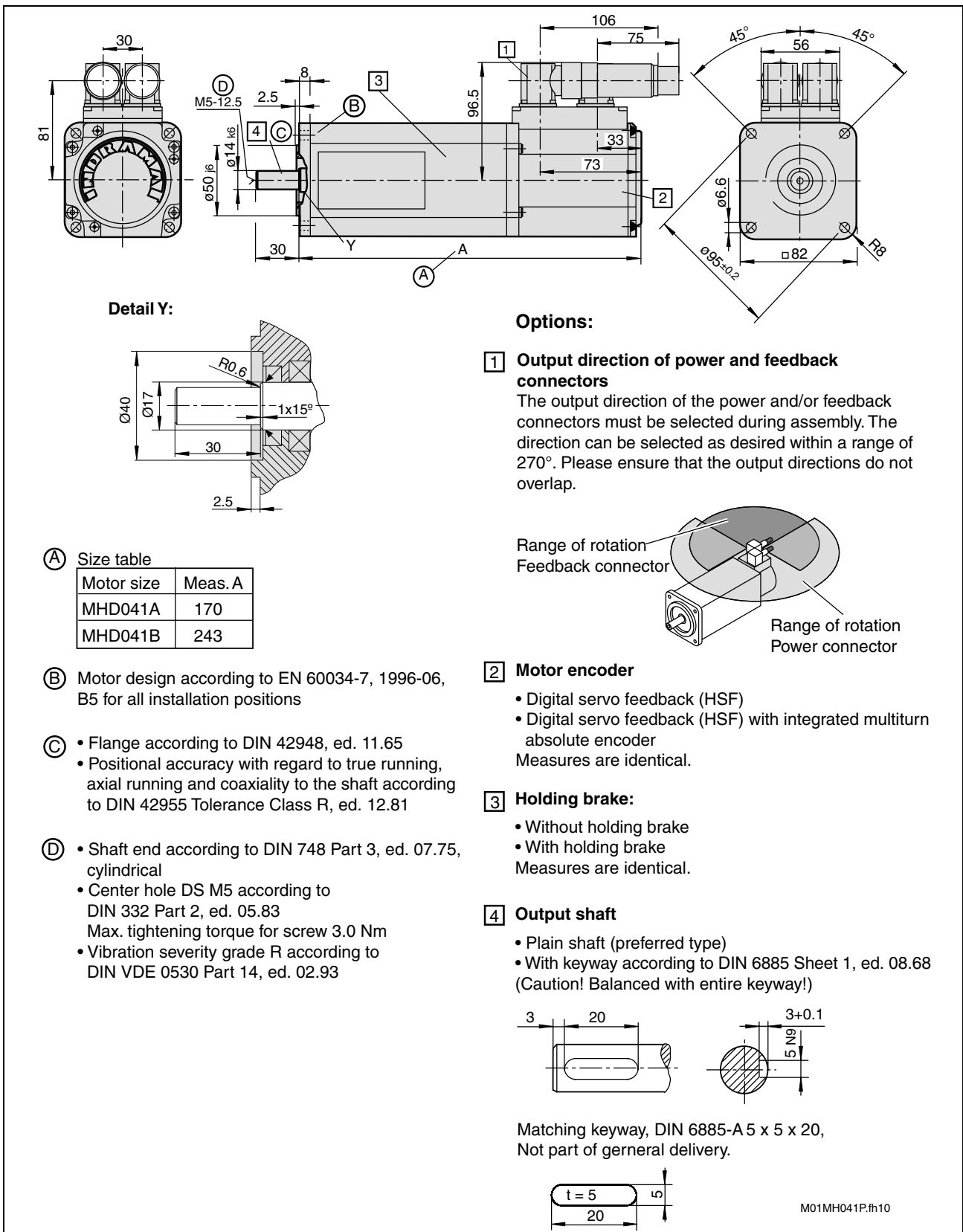

Fig. 6-8: Dimensional details of MHD041

7 MHD071

7.1 Technical data

Description	Symbol	Unit	MHD071A-061			
Type of cooling			Natural	Natural	Surface	Liquid
Motor overtemperature			60K	100 K	60 K/100	60 K/100
Electric parameters						
Characteristic motor speed	n_K	min^{-1}	4500			
Continuous torque at standstill	M_{dN}	Nm	3.5	4.0	not	not
Continuous current at standstill	I_{dN}	A	5.2	5.9	available	available
Peak current	I_{max}	A	23.4			
Torque constant at 20 °C ¹⁾	K_m	Nm/A	0.76			
Voltage constant at 20 °C	$K_{E(eff)}$	V/1000min ⁻¹	69.1			
Winding resistance at 20 °C	R12	Ω	5.2			
Winding inductivity	L12	mH	16.0			
Number of pole pairs	p		4			
Rated data ²⁾						
Rated speed	n_N	min^{-1}	5000	5000		
Rated torque	M_N	Nm	1.6	3.2		
Rated current	I_N	A	1.7	3.3	not	not
Rated performance	P_N	kW	1.0	2.1	available	available
Rated voltage	U_N	V	359	380		
Rated frequency	f_N	Hz	333	333		
Mechanical parameters						
Moment of inertia of the rotor	J_M	kgm^2	4.4×10^{-4}			
Theoretical maximum torque	M_{max}	Nm	14.0			
Minimum strand cross-section ⁴⁾	S	mm^2	1.0	1.0	not	not
time constant	T_{th}	min	45	45	lieferbar	lieferbar
Maximum speed	n_{max}	min^{-1}	6000			
Motor mass ^{3) 5)}	m	kg	6.0			
Perm. stor. a. transport temperature	T_L	°C	-20 to +80			
Permissible ambient temperature ⁶⁾	T_{um}	°C	0 to 40			
Maximum setup height ⁶⁾	h	m	1000 above MSL			
Degree of protection ⁷⁾			IP65			
Insulation class (according to DIN VDE 0530 Part 1)			F			
Housing varnish			Prime coat black in a/w RAL 9005			
¹⁾ K_m is to be used for calculations with crest values (I_{dN} , I_{max}). For calculations with root-mean-square values (rated data), the torque constant K_m must be multiplied by a factor of $\sqrt{2}$. ²⁾ Values determined according to EN 60034-1. Current and voltage specified as root-mean-square values. ³⁾ Without holding brake. ⁴⁾ Applicable to Bosch Rexroth cables. Rated according to VDE0298-4 (1992) and installation type B2 according to EN 60204-1 (1993) at an ambient temperature of 40 °C. ⁵⁾ Without blower unit. ⁶⁾ If the limits specified are exceeded, the performance data must be reduced if necessary. For reduction factors, refer to the chapter entitled "Environmental Conditions". ⁷⁾ Provided the power and encoder cables are mounted properly.						

Fig. 7-1: Technical data of MHD071A-061

Description	Symbol	Unit	MHD071B-035			
Type of cooling			Natural	Natural	Surface	Liquid
Motor overtemperature			60K	100 K	60 K/100	60 K/100
Electric parameters						
Characteristic motor speed	n_K	min^{-1}	2500			
Continuous torque at standstill	M_{dN}	Nm	8.0	9.0	12.0	not
Continuous current at standstill	I_{dN}	A	6.3	7.4	9.5	available
Peak current	I_{max}	A	28.3			
Torque constant at 20 °C ¹⁾	K_m	Nm/A	1.38			
Voltage constant at 20 °C	$K_{E(\text{eff})}$	V/1000 min^{-1}	125			
Winding resistance at 20 °C	R12	Ω	4.57			
Winding inductivity	L12	mH	23.0			
Number of pole pairs	p		4			
Rated data ²⁾						
Rated speed	n_N	min^{-1}	2500	2500	2500	
Rated torque	M_N	Nm	5.2	7.5	10.2	
Rated current	I_N	A	2.9	4.4	5.7	not
Rated performance	P_N	kW	1.6	2.5	3.4	available
Rated voltage	U_N	V	333	349	366	
Rated frequency	f_N	Hz	167	167	167	
Mechanical parameters						
Moment of inertia of the rotor	J_M	kgm^2	8.7×10^{-4}			
Theoretical maximum torque	M_{max}	Nm	32.0			
Minimum strand cross-section ⁴⁾	S	mm^2	1.0	1.0	1.0	not
time constant	T_{th}	min	45	45	20	lieferbar
Maximum speed	n_{max}	min^{-1}	6000			
Motor mass ^{3) 5)}	m	kg	8.8			
Perm. stor. a. transport temperature	T_L	°C	-20 to +80			
Permissible ambient temperature ⁶⁾	T_{um}	°C	0 to 40			
Maximum setup height ⁶⁾	h	m	1000 above MSL			
Degree of protection ⁷⁾			IP65			
Insulation class (according to DIN VDE 0530 Part 1)			F			
Housing varnish			Prime coat black in a/w RAL 9005			
¹⁾ K_m is to be used for calculations with crest values (I_{dN} , I_{max}). For calculations with root-mean-square values (rated data), the torque constant K_m must be multiplied by a factor of $\sqrt{2}$. ²⁾ Values determined according to EN 60034-1. Current and voltage specified as root-mean-square values. ³⁾ Without holding brake. ⁴⁾ Applicable to Bosch Rexroth cables. Rated according to VDE0298-4 (1992) and installation type B2 according to EN 60204-1 (1993) at an ambient temperature of 40 °C. ⁵⁾ Without blower unit. ⁶⁾ If the limits specified are exceeded, the performance data must be reduced if necessary. For reduction factors, refer to the chapter entitled "Environmental Conditions". ⁷⁾ Provided the power and encoder cables are mounted properly.						

Fig. 7-2: Technical data of MHD071B035

Description	Symbol	Unit	MHD071B-061			
Type of cooling			Natural	Natural	Surface	Liquid
Motor overtemperature			60K	100 K	60 K/100	60 K/100
Electric parameters						
Characteristic motor speed	n_K	min^{-1}	4500			
Continuous torque at standstill	M_{dN}	Nm	8.0	9.0	12.0	not
Continuous current at standstill	I_{dN}	A	11.2	13.2	16.8	available
Peak current	I_{max}	A	50.5			
Torque constant at 20 °C ¹⁾	K_m	Nm/A	0.77			
Voltage constant at 20 °C	$K_{E(\text{eff})}$	V/1000 min^{-1}	70.0			
Winding resistance at 20 °C	R12	Ω	1.45			
Winding inductivity	L12	mH	7.2			
Number of pole pairs	p		4			
Rated data ²⁾						
Rated speed	n_N	min^{-1}	4000	5000	5000	
Rated torque	M_N	Nm	1.7	5.3	7.8	
Rated current	I_N	A	1.7	5.5	7.7	not
Rated performance	P_N	kW	0.8	3.4	4.8	available
Rated voltage	U_N	V	283	368	380	
Rated frequency	f_N	Hz	267	333	333	
Mechanical parameters						
Moment of inertia of the rotor	J_M	kgm^2	8.7×10^{-4}			
Theoretical maximum torque	M_{max}	Nm	32.0			
Minimum strand cross-section ⁴⁾	S	mm^2	1.0	1.0	1.0	not
time constant	T_{th}	min	45	45	20	lieferbar
Maximum speed	n_{max}	min^{-1}	6000			
Motor mass ^{3) 5)}	m	kg	8.8			
Perm. stor. a. transport temperature	T_L	°C	-20 to +80			
Permissible ambient temperature ⁶⁾	T_{um}	°C	0 to 40			
Maximum setup height ⁶⁾	h	m	1000 above MSL			
Degree of protection ⁷⁾			IP65			
Insulation class (according to DIN VDE 0530 Part 1)			F			
Housing varnish			Prime coat black in a/w RAL 9005			
¹⁾ K_m is to be used for calculations with crest values (I_{dN} , I_{max}). For calculations with root-mean-square values (rated data), the torque constant K_m must be multiplied by a factor of $\sqrt{2}$. ²⁾ Values determined according to EN 60034-1. Current and voltage specified as root-mean-square values. ³⁾ Without holding brake. ⁴⁾ Applicable to Bosch Rexroth cables. Rated according to VDE0298-4 (1992) and installation type B2 according to EN 60204-1 (1993) at an ambient temperature of 40 °C. ⁵⁾ Without blower unit. ⁶⁾ If the limits specified are exceeded, the performance data must be reduced if necessary. For reduction factors, refer to the chapter entitled "Environmental Conditions". ⁷⁾ Provided the power and encoder cables are mounted properly.						

Fig. 7-3: Technical data of MHD071B-061

Holding brake

Description	Symbol	Unit	Holding brake 1	Holding brake 2	Holding brake 3
Motor type			MHD071B		
Holding torque	M_4	Nm	5.0	6.5	10.0
Rated voltage	U_N	V	DC 24 ± 10%	DC 24 ± 10%	DC 24 ± 10%
Rated current	I_N	A	0.56	0.56	0.65
Moment of inertia	J_B	kgm ²	0.72×10^{-4}	0.72×10^{-4}	10.7×10^{-4}
Connection time	t_1	ms	20	20	26
Disconnection time	t_2	ms	38	38	43
Mass	m_B	kg	0.6	0.6	0.7

Fig. 7-4: Technical data of MHD071 holding brake (optional)

Note: Motors of size MHD071A are only available without holding brake.

7.2 Type Code – Ordering Name

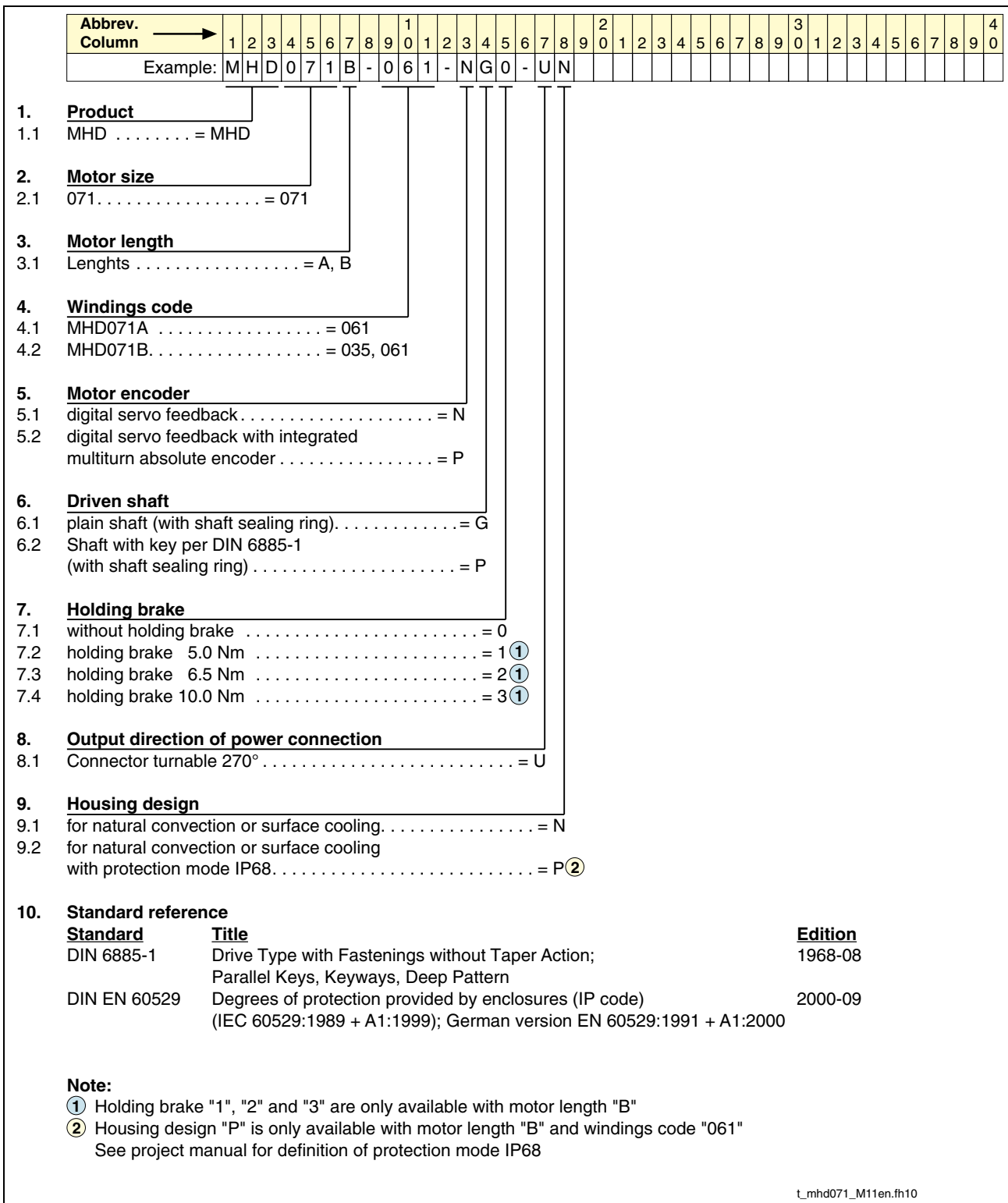
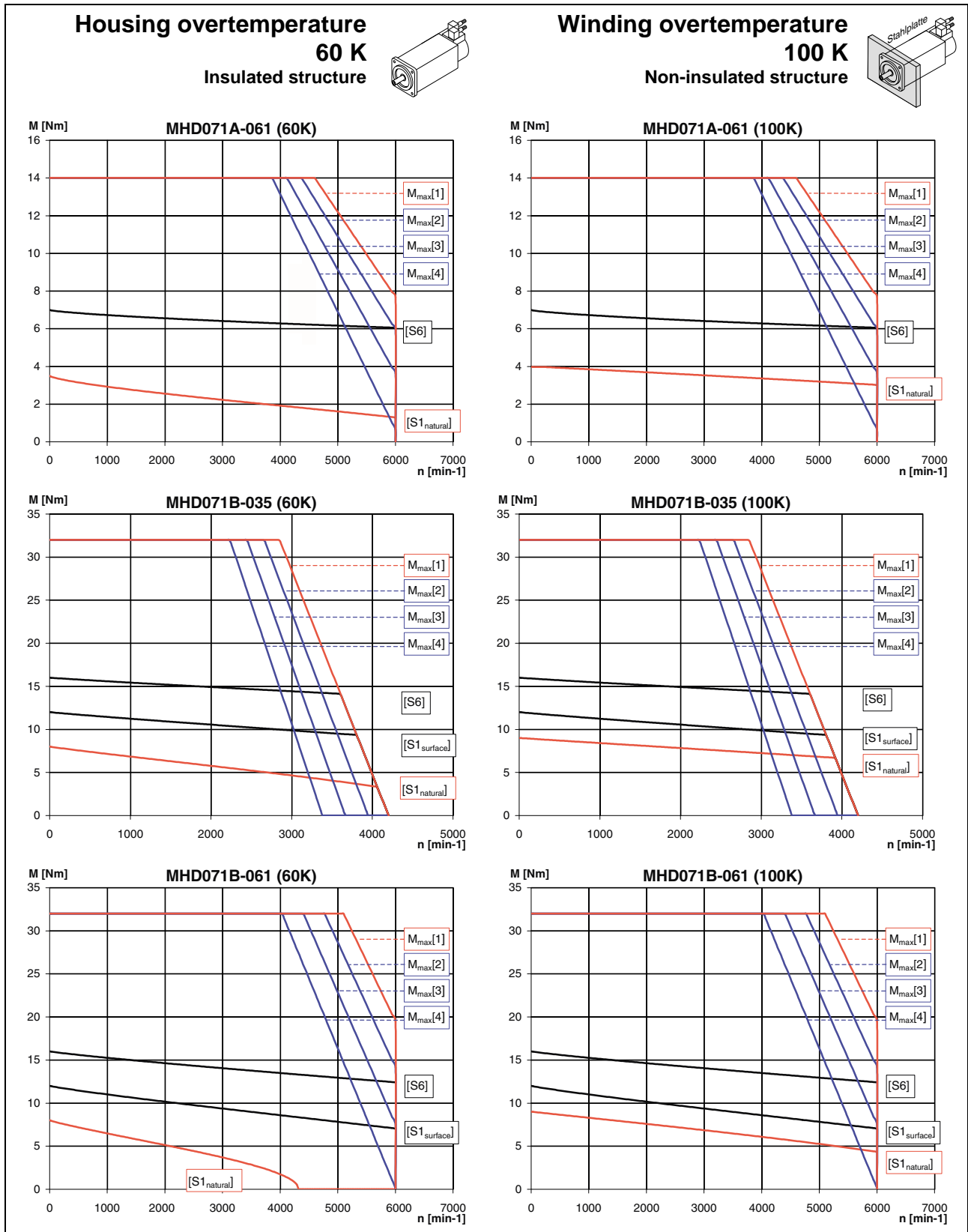

Fig. 7-5: MDH071 type code

7.3 Speed-Torque Curves



[S1_{natural}]: M_{dN} Natural conv. (S1 continuous operation)

[S1_{surface}]: M_{dN} Surface cooling (S1 continuous operation)

[S6]: M_{KB} (S6 intermittent operation)

M_{max}[1]: HDS to HVR

M_{max}[2]: HDS to HVE or DKCxx.3 with a power connection of 3 x AC 480 V

M_{max}[3]: HDS to HVE or DKCxx.3 with a power connection of 3 x AC 440 V

M_{max}[4]: HDS to HVE or DKCxx.3 with a power connection of 3 x AC 400 V

Fig. 7-6: Characteristic curves

7.4 Shaft loads

Permissible maximum radial force $F_{\text{radial_max}}$ and permissible radial force F_{radial}

For explanations refer to Chapter 16.7

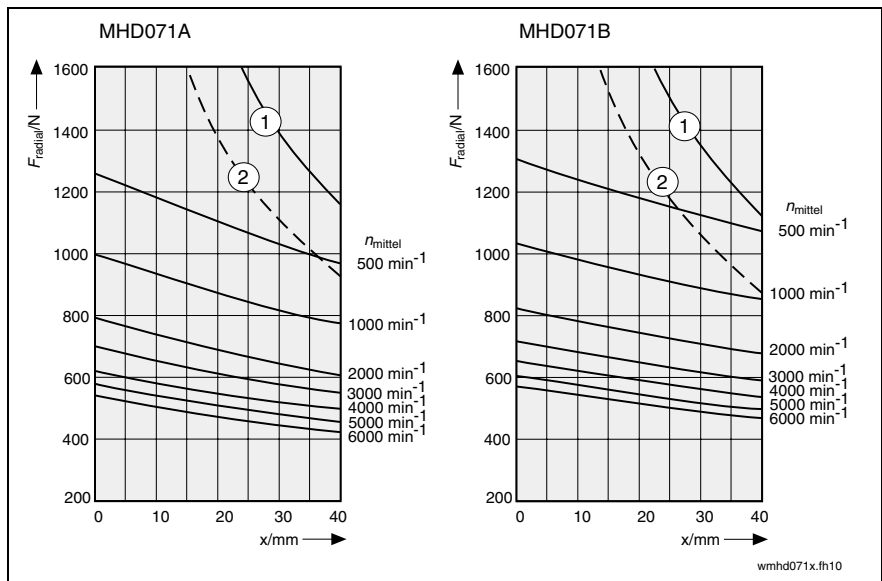

- (1): $F_{\text{radial_max}}$ (plain shaft)
- (2): $F_{\text{radial_max}}$ (shaft with keyway)

Fig. 7-7: MHD071: Permissible maximum radial force $F_{\text{radial_max}}$ and permissible radial force F_{radial}

Permissible axial force F_{axial}

$$F_{\text{axial}} = x \cdot F_{\text{radial}}$$

- x: 0.58 for MHD071A
0.55 for MHD071B
- F_{axial} : permissible axial force in N
- F_{radial} : permissible radial force in N

Fig. 7-8: MHD071: permissible axial force F_{axial}

7.5 Dimensional Details

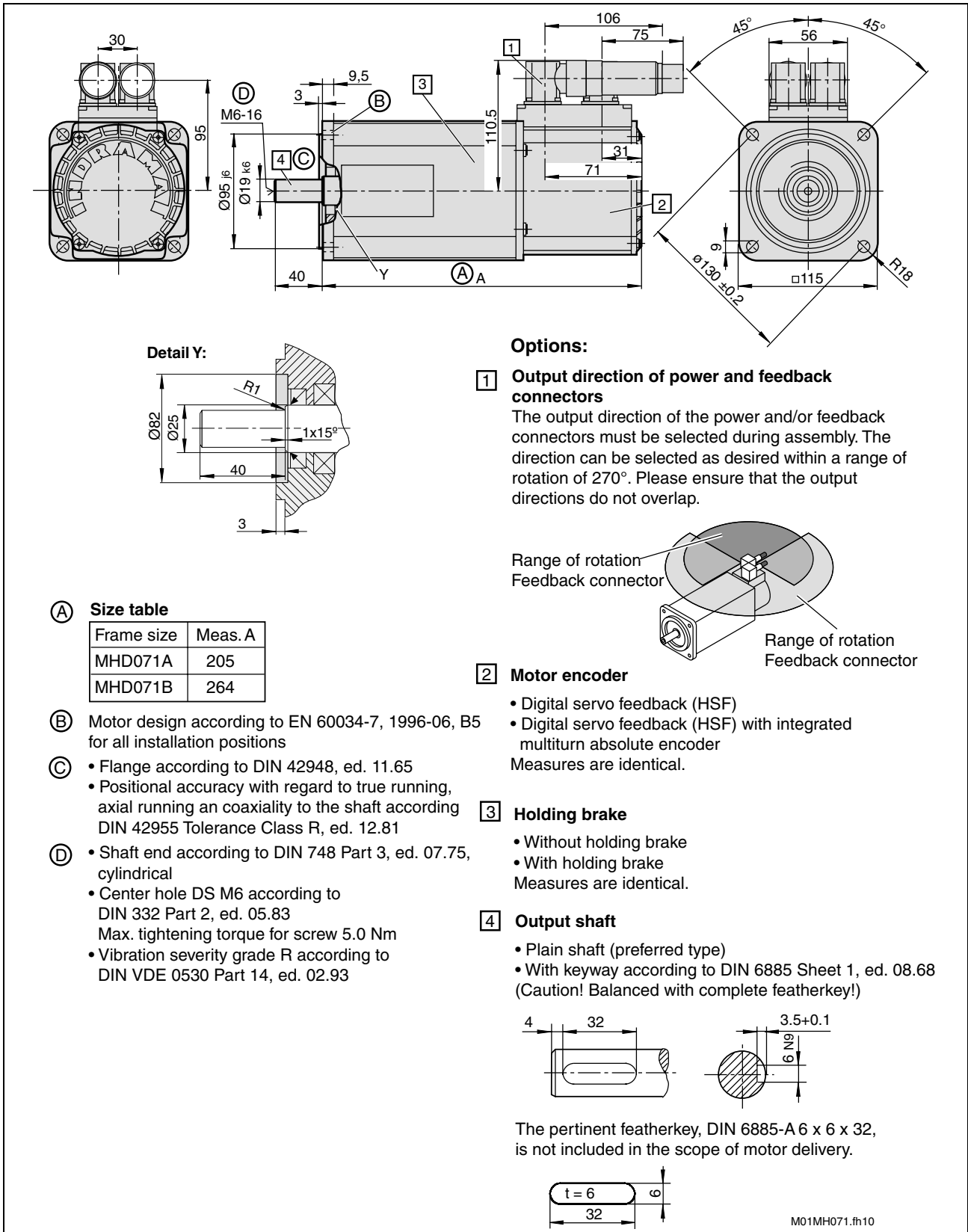

Fig. 7-9: Dimensional details of MHD071

7.6 Blower Units

MHD motors can also be delivered with optional blower units. Please refer to the "Surface" column of the data sheets for performance data of surface-cooled motors. The mechanical dimensions of the blower units are represented in the dimension drawings. The possibilities of combining motor and blower unit and the technical data of the blowers are represented in the table below.

Motor			Ordering name of blower unit			
			LEMD-RB071B1XX	LEMD-RB071B2XX		
MHD071A			---	---		
MHD071B			x	x		

Technical data of blower unit						
Description	Symbol	Unit				
Type of cooling			Radial		axial	
Rated voltage	U_n	V	230 V, $\pm 15\%$ 50 Hz	115 V, $\pm 10\%$ 60 Hz	Not available	Not available
Power consumption	S_n	VA	18	17		
Rated current	I	A	0.13	0.28		
Mean air volume	V	m ³ /h	180	206		
Blower unit mass	m_L	kg	2.2	2.2		
Noise level		dB(A)	44	47		
Air flow			B \Rightarrow A blowing			

--- Blower installation not possible; x Blower installation possible

Fig. 7-10: Technical data of MHD071 blower units (optional)

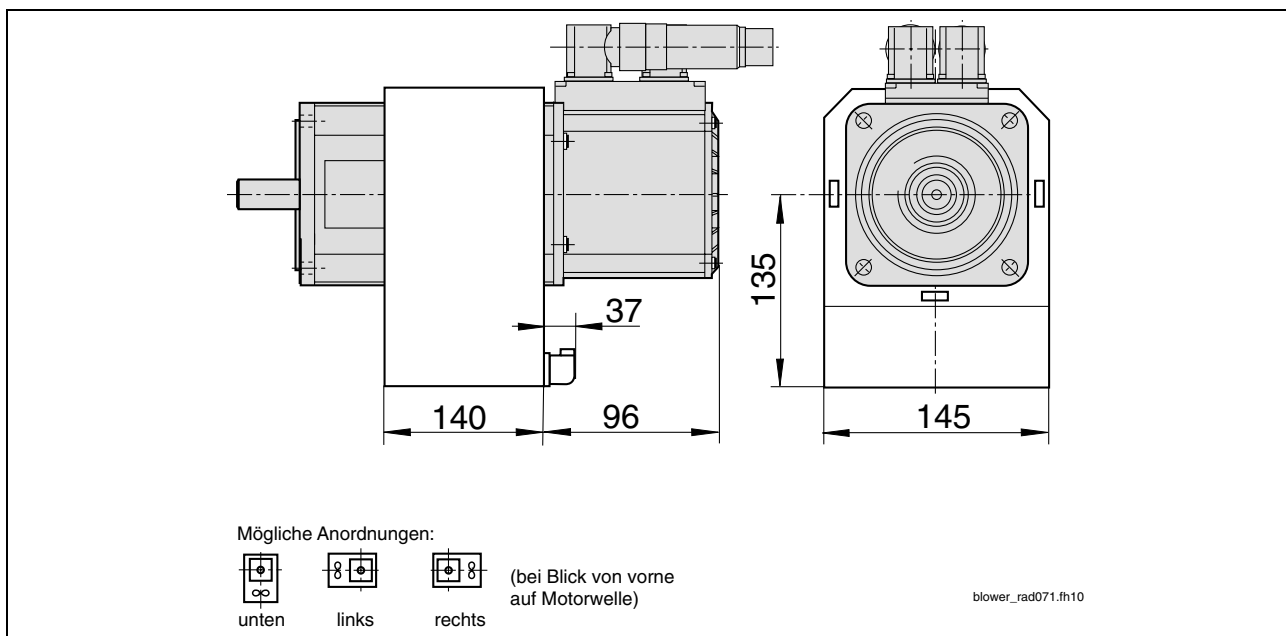

Fig. 7-11: Dimensional details about MHD071 with radial blower

8 MHD090

8.1 Technical data

Description	Symbol	Unit	MHD090B-035			
			Natural 60K	Natural 100 K	Surface 60 K/100	Liquid 60 K/100
Type of cooling			Natural 60K	Natural 100 K	Surface 60 K/100	Liquid 60 K/100
Motor overtemperature						
Electric parameters						
Characteristic motor speed	n_K	min^{-1}	2500			
Continuous torque at standstill	M_{dN}	Nm	12.0	13.5	18.0	not
Continuous current at standstill	I_{dN}	A	11.0	12.5	16.5	available
Peak current	I_{max}	A	49.5			
Torque constant at 20 °C ¹⁾	K_m	Nm/A	1.22			
Voltage constant at 20 °C	$K_{E(eff)}$	V/1000min ⁻¹	111.0			
Winding resistance at 20 °C	R12	Ω	1.88			
Winding inductivity	L12	mH	15.5			
Number of pole pairs	p		4			
Rated data ²⁾						
Rated speed	n_N	min^{-1}	3000	3000	3000	
Rated torque	M_N	Nm	7.2	10.2	15.0	
Rated current	I_N	A	4.7	6.7	9.7	not
Rated performance	P_N	kW	2.8	4.0	5.9	available
Rated voltage	U_N	V	354	369	399	
Rated frequency	f_N	Hz	200	200	200	
Mechanical parameters						
Moment of inertia of the rotor	J_M	kgm^2	43.0×10^{-4}			
Theoretical maximum torque	M_{max}	Nm	43.5			
Minimum strand cross-section ⁴⁾	S	mm^2	1.0	1.0	1.0	not
time constant	T_{th}	min	60	60	30	lieferbar
Maximum speed	n_{max}	min^{-1}	5000			
Motor mass ^{3) 5)}	m	kg	14.0			
Perm. stor. a. transport temperature	T_L	°C	-20 to +80			
Permissible ambient temperature ⁶⁾	T_{um}	°C	0 to 40			
Maximum setup height ⁶⁾	h	m	1000 above MSL			
Degree of protection ⁷⁾			IP65			
Insulation class (according to DIN VDE 0530 Part 1)			F			
Housing varnish			Prime coat black in a/w RAL 9005			
¹⁾ K_m is to be used for calculations with crest values (I_{dN} , I_{max}). For calculations with root-mean-square values (rated data), the torque constant K_m must be multiplied by a factor of $\sqrt{2}$. ²⁾ Values determined according to EN 60034-1. Current and voltage specified as root-mean-square values. ³⁾ Without holding brake. ⁴⁾ Applicable to Bosch Rexroth cables. Rated according to VDE0298-4 (1992) and installation type B2 according to EN 60204-1 (1993) at an ambient temperature of 40 °C. ⁵⁾ Without blower unit. ⁶⁾ If the limits specified are exceeded, the performance data must be reduced if necessary. For reduction factors, refer to the chapter entitled "Environmental Conditions". ⁷⁾ Provided the power and encoder cables are mounted properly.						

Fig. 8-1: Technical data of MHD090B-035

Description	Symbol	Unit	MHD090B-047			
Type of cooling			Natural	Natural	Surface	Liquid
Motor overtemperature			60K	100 K	60 K/100	60 K/100
Electric parameters						
Characteristic motor speed	n_K	min^{-1}	3200			
Continuous torque at standstill	M_{dN}	Nm	12.0	13.5	18.0	not
Continuous current at standstill	I_{dN}	A	13.2	16.2	19.8	available
Peak current	I_{max}	A	59.4			
Torque constant at 20 °C ¹⁾	K_m	Nm/A	1.0			
Voltage constant at 20 °C	$K_{E(\text{eff})}$	V/1000min ⁻¹	91.0			
Winding resistance at 20 °C	R12	Ω	1.2			
Winding inductivity	L12	mH	10.1			
Number of pole pairs	p		4			
Rated data ²⁾						
Rated speed	n_N	min^{-1}	3500	3500	3500	
Rated torque	M_N	Nm	6.2	9.9	14.4	
Rated current	I_N	A	4.8	8.4	11.2	not
Rated performance	P_N	kW	2.7	4.8	6.4	available
Rated voltage	U_N	V	332	351	371	
Rated frequency	f_N	Hz	233	233	233	
Mechanical parameters						
Moment of inertia of the rotor	J_M	kgm^2	43.0×10^{-4}			
Theoretical maximum torque	M_{max}	Nm	43.5			
Minimum strand cross-section ⁴⁾	S	mm^2	1.0	1.0	1.5	not
time constant	T_{th}	min	60	60	30	lieferbar
Maximum speed	n_{max}	min^{-1}	5000			
Motor mass ^{3) 5)}	m	kg	14.0			
Perm. stor. a. transport temperature	T_L	°C	-20 to +80			
Permissible ambient temperature ⁶⁾	T_{um}	°C	0 to 40			
Maximum setup height ⁶⁾	h	m	1000 above MSL			
Degree of protection ⁷⁾			IP65			
Insulation class (according to DIN VDE 0530 Part 1)			F			
Housing varnish			Prime coat black in a/w RAL 9005			
¹⁾ K_m is to be used for calculations with crest values (I_{dN} , I_{max}). For calculations with root-mean-square values (rated data), the torque constant K_m must be multiplied by a factor of $\sqrt{2}$. ²⁾ Values determined according to EN 60034-1. Current and voltage specified as root-mean-square values. ³⁾ Without holding brake. ⁴⁾ Applicable to Bosch Rexroth cables. Rated according to VDE0298-4 (1992) and installation type B2 according to EN 60204-1 (1993) at an ambient temperature of 40 °C. ⁵⁾ Without blower unit. ⁶⁾ If the limits specified are exceeded, the performance data must be reduced if necessary. For reduction factors, refer to the chapter entitled "Environmental Conditions". ⁷⁾ Provided the power and encoder cables are mounted properly.						

Fig. 8-2: Technical data of MHD090B-047

Description	Symbol	Unit	MHD090B-058			
Type of cooling			Natural	Natural	Surface	Liquid
Motor overtemperature			60K	100 K	60 K/100	60 K/100
Electric parameters						
Characteristic motor speed	n_K	min^{-1}	4000			
Continuous torque at standstill	M_{dN}	Nm	12.0	13.5	18.0	not
Continuous current at standstill	I_{dN}	A	17.5	21.0	26.3	available
Peak current	I_{max}	A	79.0			
Torque constant at 20 °C ¹⁾	K_m	Nm/A	0.77			
Voltage constant at 20 °C	$K_{E(\text{eff})}$	V/1000min ⁻¹	70.0			
Winding resistance at 20 °C	R12	Ω	0.74			
Winding inductivity	L12	mH	5.8			
Number of pole pairs	p		4			
Rated data ²⁾						
Rated speed	n_N	min^{-1}	4000	4000	4000	
Rated torque	M_N	Nm	4.2	8.9	13.4	
Rated current	I_N	A	4.3	9.8	13.8	not
Rated performance	P_N	kW	2.1	4.9	7.0	available
Rated voltage	U_N	V	286	303	320	
Rated frequency	f_N	Hz	267	267	267	
Mechanical parameters						
Moment of inertia of the rotor	J_M	kgm^2	43.0×10^{-4}			
Theoretical maximum torque	M_{max}	Nm	43.5			
Minimum strand cross-section ⁴⁾	S	mm^2	1.0	1.5	2.5	not
time constant	T_{th}	min	60	60	30	lieferbar
Maximum speed	n_{max}	min^{-1}	5000			
Motor mass ^{3) 5)}	m	kg	14.0			
Perm. stor. a. transport temperature	T_L	°C	-20 to +80			
Permissible ambient temperature ⁶⁾	T_{um}	°C	0 to 40			
Maximum setup height ⁶⁾	h	m	1000 above MSL			
Degree of protection ⁷⁾			IP65			
Insulation class (according to DIN VDE 0530 Part 1)			F			
Housing varnish			Prime coat black in a/w RAL 9005			
¹⁾ K_m is to be used for calculations with crest values (I_{dN} , I_{max}). For calculations with root-mean-square values (rated data), the torque constant K_m must be multiplied by a factor of $\sqrt{2}$. ²⁾ Values determined according to EN 60034-1. Current and voltage specified as root-mean-square values. ³⁾ Without holding brake. ⁴⁾ Applicable to Bosch Rexroth cables. Rated according to VDE0298-4 (1992) and installation type B2 according to EN 60204-1 (1993) at an ambient temperature of 40 °C. ⁵⁾ Without blower unit. ⁶⁾ If the limits specified are exceeded, the performance data must be reduced if necessary. For reduction factors, refer to the chapter entitled "Environmental Conditions". ⁷⁾ Provided the power and encoder cables are mounted properly.						

Fig. 8-3: Technical data of MHD090B-058

Holding brake

Description	Symbol	Unit	Holding brake data
Motor type			MHD090B
Holding torque	M_4	Nm	11.0
Rated voltage	U_N	V	DC 24 ± 10%
Rated current	I_N	A	0.71
Moment of inertia	J_B	Kgm ²	1.66×10^{-4}
Connection time	t_1	ms	10
Disconnection time	t_2	ms	50
Mass	m_B	kg	1.0

Fig. 15-5: Technical data of MHD090 holding brake (optional)

8.2 Type Code – Ordering Name

Abbrev. Column	1	2	3	4	5	6	7	8	9	0	1	2	3	4	5	6	7	8	9	0	2	1	2	3	4	5	6	7	8	9	0	3	1	2	3	4	5	6	7	8	9	0	4									
Example:	M	H	D	0	9	0	B	-	0	3	5	-	N	G	0	-	U	N																																		

- 1. Product**
1.1 MHD = MHD

- 2. Motor size**
2.1 090 = 090

- 3. Motor length**
3.1 Length = B

- 4. Windings code**
4.1 MHD090B = 035, 047, 058

- 5. Motor encoder**
5.1 digital servo feedback = N
5.2 digital servo feedback with integrated multiturn absolute encoder = P

- 6. Driven shaft**
6.1 plain shaft (with shaft sealing ring) = G
6.2 Shaft with key per DIN 6885-1 (with shaft sealing ring) = P

- 7. Holding brake**
7.1 without holding brake = 0
7.2 holding brake 11 Nm = 1
7.3 holding brake 18 Nm = 2

- 8. Output direction of power connection**
8.1 Connector turnable 270° = U

- 9. Housing design**
9.1 for natural convection or surface cooling = N
9.2 for natural convection or surface cooling with protection mode IP68 = P ①

- 10. Standard reference**

Standard	Title	Edition
DIN 6885-1	Drive Type with Fastenings without Taper Action; Parallel Keys, Keyways, Deep Pattern	1968-08
DIN EN 60529	Degrees of protection provided by enclosures (IP code) (IEC 60529:1989 + A1:1999); German version EN 60529:1991 + A1:2000	2000-09

Note:
① Housing design "P" is only available with windings code "058"
See project manual for definition of protection mode IP68

t_mhd090_M08en.fh10

Fig. 8-5: MHD090 type code

8.3 Speed-Torque Curves

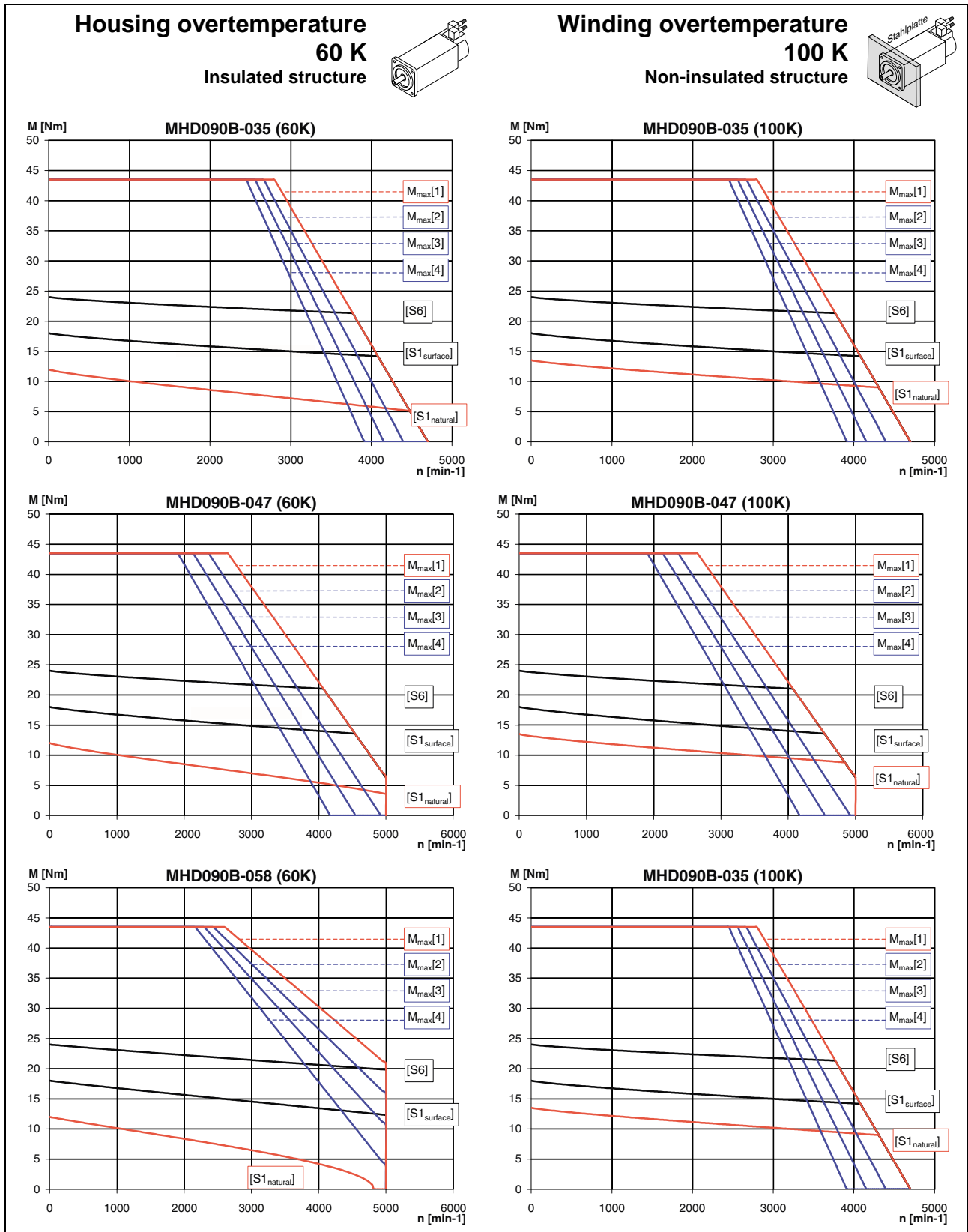

[S1_{natural}]: M_{dN} Natural conv. (S1 continuous operation)

[S1_{surface}]: M_{dN} Surface cooling (S1 continuous operation)

[S6]: M_{KB} (S6 intermittent operation)

$M_{max}[1]$: HDS to HVR

$M_{max}[2]$: HDS to HVE or DKCxx.3 with a power connection of 3 x AC 480 V

$M_{max}[3]$: HDS to HVE or DKCxx.3 with a power connection of 3 x AC 440 V

$M_{max}[4]$: HDS to HVE or DKCxx.3 with a power connection of 3 x AC 400 V

Fig. 8-6: Characteristic curves

8.4 Shaft loads

Permissible maximum radial force $F_{\text{radial_max}}$ and permissible radial force F_{radial}

For explanations refer to Chapter 16.7

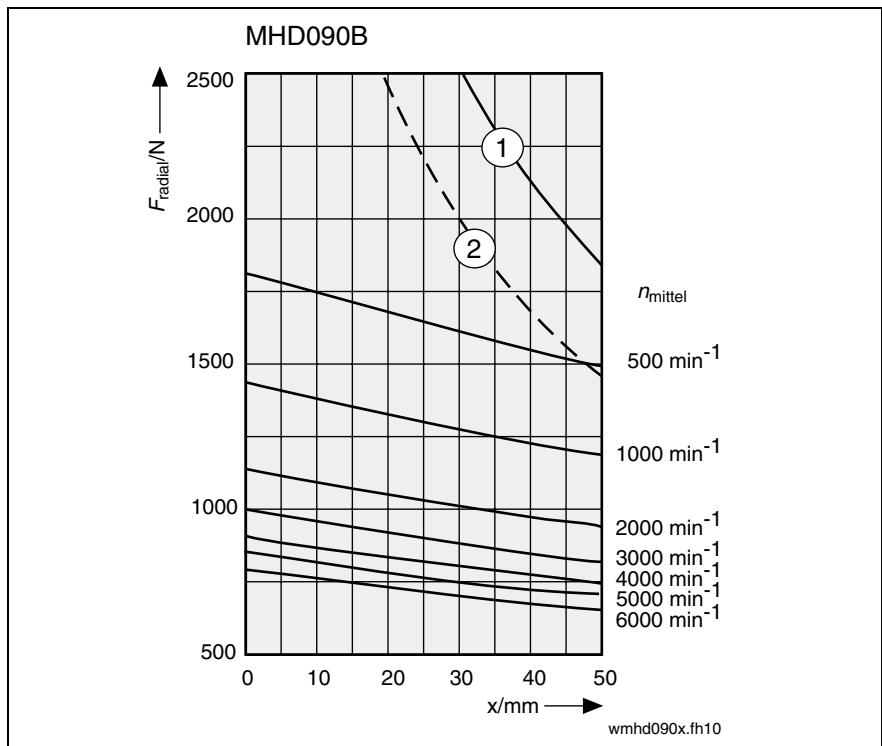

Fig. 8-7: MHD090: Permissible maximum radial force $F_{\text{radial_max}}$ and permissible radial force F_{radial}

Permissible axial force F_{axial}

$$F_{\text{axial}} = x \cdot F_{\text{radial}}$$

- x: 0.34 for MHD090B
- F_{axial} : permissible axial force in N
- F_{radial} : permissible radial force in N

Fig. 8-8: MHD090: permissible axial force F_{axial}

8.5 Dimensional Details

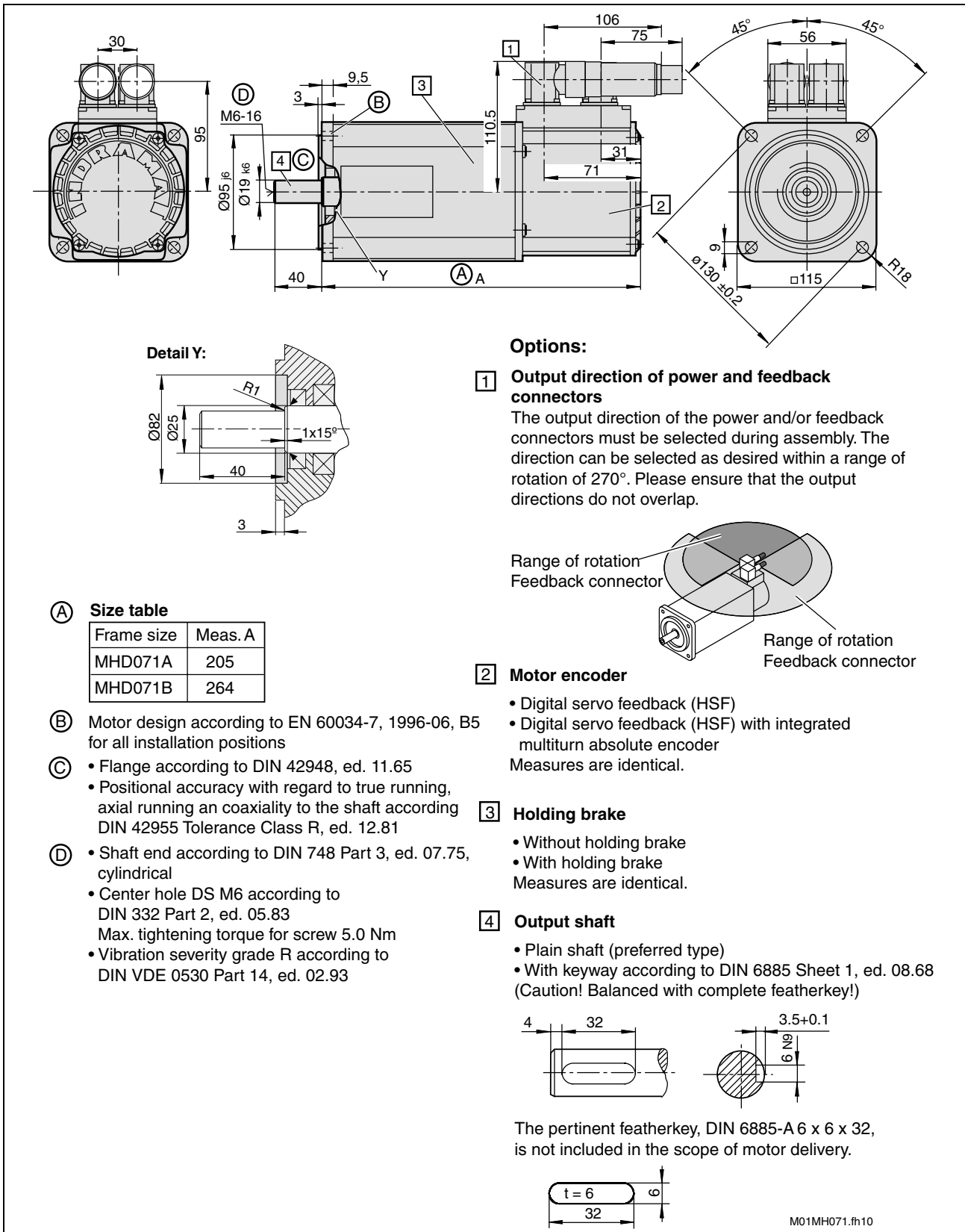

Fig. 8-9: MHD090 specifications

8.6 Blower Units

MHD motors can also be delivered with optional blower units. Please refer to the “Surface” column of the data sheets for performance data of surface-cooled motors. The mechanical dimensions of the blower units are represented in the dimension drawings. The possibilities of combining motor and blower unit and the technical data of the blowers are represented in the table below.

Motor			Ordering name of blower unit			
			LEMH-RB090B1XX	LEMH-RB090B2XX		
MHD090B			x	x		

Technical data of blower unit						
Description	Symbol	Unit				
Type of cooling			Radial		axial	
Rated voltage	U_n	V	230 V, $\pm 15\%$ 50 / 60 Hz	115 V, $\pm 10\%$ 50 / 60 Hz	Not available	Not available
Power consumption	S_n	VA	45 / 43	40 / 39		
Rated current	I	A	0.31 / 0.25	0.53 / 0.46		
Mean air volume	V	m ³ /h	340	390		
Blower unit mass	m_L	kg	1.2	1.1		
Noise level		dB(A)	48 / 52	48 / 52		
Air flow			B \Rightarrow A blowing			

--- Blower installation not possible; x Blower installation possible

Fig. 8-10: Technical data of MHD090 blower units (optional)

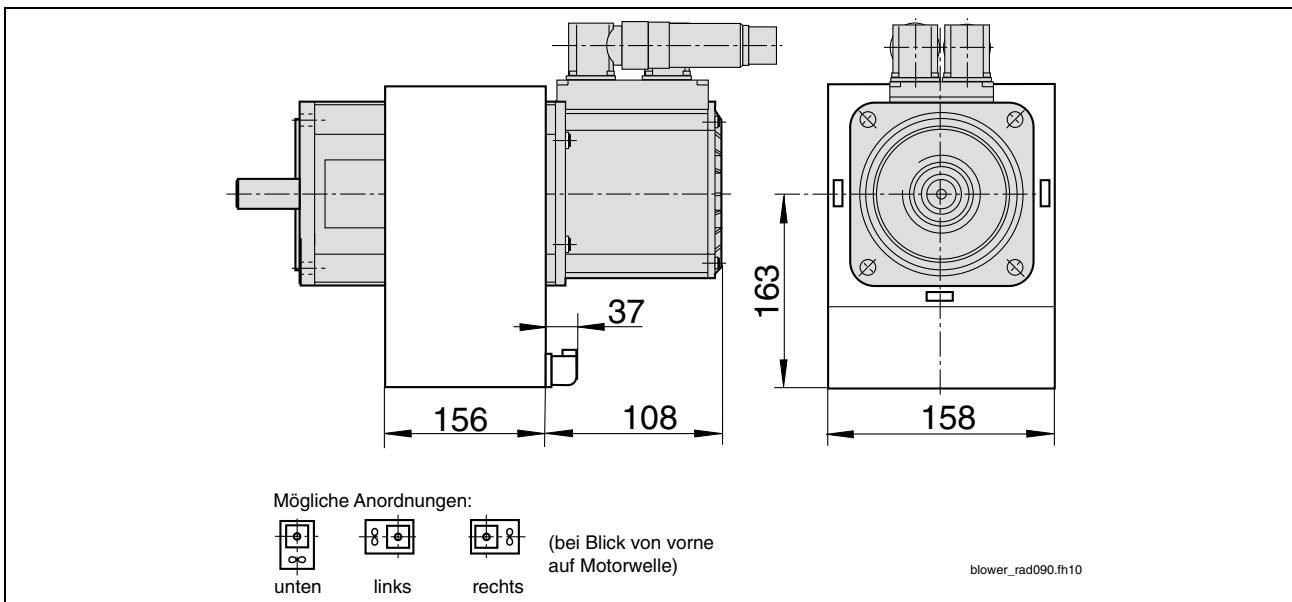

Fig. 8-11: MHD090 blower unit

9 MHD093

9.1 Technical data

Description	Symbol	Unit	MHD093A-024			
			Natural 60K	Natural 100 K	Surface 60 K/100	Liquid 60 K/100
Type of cooling			Natural 60K	Natural 100 K	Surface 60 K/100	Liquid 60 K/100
Motor overtemperature						
Electric parameters						
Characteristic motor speed	n_K	min^{-1}	2000			
Continuous torque at standstill	M_{dN}	Nm	12.0	14.0	18.0	22.8
Continuous current at standstill	I_{dN}	A	7.6	8.9	11.4	14.4
Peak current	I_{max}	A	34.2			
Torque constant at 20 °C ¹⁾	K_m	Nm/A	1.77			
Voltage constant at 20 °C	$K_{E(eff)}$	V/1000min ⁻¹	154.0			
Winding resistance at 20 °C	R12	Ω	2.95			
Winding inductivity	L12	mH	19.3			
Number of pole pairs	p		4			
Rated data ²⁾						
Rated speed	n_N	min^{-1}	2000	2000	2000	2000
Rated torque	M_N	Nm	8.3	11.2	15.7	21.0
Rated current	I_N	A	3.7	5.3	7.0	9.4
Rated performance	P_N	kW	2.1	2.8	4.0	5.5
Rated voltage	U_N	V	325	333	348	368
Rated frequency	f_N	Hz	133	133	133	133
Mechanical parameters						
Moment of inertia of the rotor	J_M	kgm^2	17.3×10^{-4}			
Theoretical maximum torque	M_{max}	Nm	44.0			
Minimum strand cross-section ⁴⁾	S	mm^2	1.5	1.5	1.5	1.5
time constant	T_{th}	min	40	40	20	12
Maximum speed	n_{max}	min^{-1}	6000			
Motor mass ^{3) 5)}	m	kg	14.5			
Perm. stor. a. transport temperature	T_L	°C	-20 to +80			
Permissible ambient temperature ⁶⁾	T_{um}	°C	0 to 40			
Maximum setup height ⁶⁾	h	m	1000 above MSL			
Degree of protection ⁷⁾			IP65			
Insulation class (according to DIN VDE 0530 Part 1)			F			
Housing varnish			Prime coat black in a/w RAL 9005			
¹⁾ K_m is to be used for calculations with crest values (I_{dN} , I_{max}). For calculations with root-mean-square values (rated data), the torque constant K_m must be multiplied by a factor of $\sqrt{2}$. ²⁾ Values determined according to EN 60034-1. Current and voltage specified as root-mean-square values. ³⁾ Without holding brake. ⁴⁾ Applicable to Bosch Rexroth cables. Rated according to VDE0298-4 (1992) and installation type B2 according to EN 60204-1 (1993) at an ambient temperature of 40 °C. ⁵⁾ Without blower unit. ⁶⁾ If the limits specified are exceeded, the performance data must be reduced if necessary. For reduction factors, refer to the chapter entitled "Environmental Conditions". ⁷⁾ Provided the power and encoder cables are mounted properly.						

Fig. 9-1: Technical data of MHD093A-024

Description	Symbol	Unit	MHD093A-035			
Type of cooling			Natural	Natural	Surface	Liquid
Motor overtemperature			60K	100 K	60 K/100	60 K/100
Electric parameters						
Characteristic motor speed	n_K	min^{-1}	3000			
Continuous torque at standstill	M_{dN}	Nm	12.0	14.0	18.0	22.8
Continuous current at standstill	I_{dN}	A	10.2	11.9	15.3	19.4
Peak current	I_{max}	A	45.9			
Torque constant at 20 °C ¹⁾	K_m	Nm/A	1.29			
Voltage constant at 20 °C	$K_{E(eff)}$	V/1000min ⁻¹	112.2			
Winding resistance at 20 °C	R12	Ω	1.75			
Winding inductivity	L12	mH	10.8			
Number of pole pairs	p		4			
Rated data ²⁾						
Rated speed	n_N	min^{-1}	3000	3000	3000	3000
Rated torque	M_N	Nm	6.1	10.0	14.3	19.9
Rated current	I_N	A	3.7	6.0	8.6	12.0
Rated performance	P_N	kW	2.2	3.6	5.2	7.4
Rated voltage	U_N	V	347	357	371	393
Rated frequency	f_N	Hz	200	200	200	200
Mechanical parameters						
Moment of inertia of the rotor	J_M	kgm^2	17.3×10^{-4}			
Theoretical maximum torque	M_{max}	Nm	44.0			
Minimum strand cross-section ⁴⁾	S	mm^2	1.5	1.5	1.5	2.5
time constant	T_{th}	min	40	40	20	12
Maximum speed	n_{max}	min^{-1}	4500			
Motor mass ^{3) 5)}	m	kg	14.5			
Perm. stor. a. transport temperature	T_L	°C	-20 to +80			
Permissible ambient temperature ⁶⁾	T_{um}	°C	0 to 40			
Maximum setup height ⁶⁾	h	m	1000 above MSL			
Degree of protection ⁷⁾			IP65			
Insulation class (according to DIN VDE 0530 Part 1)			F			
Housing varnish			Prime coat black in a/w RAL 9005			
¹⁾ K_m is to be used for calculations with crest values (I_{dN} , I_{max}). For calculations with root-mean-square values (rated data), the torque constant K_m must be multiplied by a factor of $\sqrt{2}$. ²⁾ Values determined according to EN 60034-1. Current and voltage specified as root-mean-square values. ³⁾ Without holding brake. ⁴⁾ Applicable to Bosch Rexroth cables. Rated according to VDE0298-4 (1992) and installation type B2 according to EN 60204-1 (1993) at an ambient temperature of 40 °C. ⁵⁾ Without blower unit. ⁶⁾ If the limits specified are exceeded, the performance data must be reduced if necessary. For reduction factors, refer to the chapter entitled "Environmental Conditions". ⁷⁾ Provided the power and encoder cables are mounted properly.						

Fig. 9-2: Technical data of MHD093A-035

Description	Symbol	Unit	MHD093A-058			
			Natural 60K	Natural 100 K	Surface 60 K/100	Liquid 60 K/100
Type of cooling						
Motor overtemperature			60K	100 K	60 K/100	60 K/100
Electric parameters						
Characteristic motor speed	n_K	min^{-1}	4000			
Continuous torque at standstill	M_{dN}	Nm	12.0	14.0	18.0	22.8
Continuous current at standstill	I_{dN}	A	12.8	15.1	19.2	24.3
Peak current	I_{max}	A	57.6			
Torque constant at 20 °C ¹⁾	K_m	Nm/A	1.05			
Voltage constant at 20 °C	$K_{E(\text{eff})}$	V/1000min ⁻¹	91.3			
Winding resistance at 20 °C	R12	Ω	1.09			
Winding inductivity	L12	mH	6.9			
Number of pole pairs	p		4			
Rated data ²⁾						
Rated speed	n_N	min^{-1}	3500	3500	3500	3500
Rated torque	M_N	Nm	4.5	8.6	13.6	19.3
Rated current	I_N	A	3.4	6.6	10.3	14.6
Rated performance	P_N	kW	1.9	3.7	5.9	8.5
Rated voltage	U_N	V	325	327	347	366
Rated frequency	f_N	Hz	233	233	233	233
Mechanical parameters						
Moment of inertia of the rotor	J_M	kgm^2	17.3×10^{-4}			
Theoretical maximum torque	M_{max}	Nm	44.0			
Minimum strand cross-section ⁴⁾	S	mm^2	1.5	1.5	1.5	2.5
time constant	T_{th}	min	40	40	20	12
Maximum speed	n_{max}	min^{-1}	6000			
Motor mass ^{3) 5)}	m	kg	14.5			
Perm. stor. a. transport temperature	T_L	°C	-20 to +80			
Permissible ambient temperature ⁶⁾	T_{um}	°C	0 to 40			
Maximum setup height ⁶⁾	h	m	1000 above MSL			
Degree of protection ⁷⁾			IP65			
Insulation class (according to DIN VDE 0530 Part 1)			F			
Housing varnish			Prime coat black in a/w RAL 9005			
¹⁾ K_m is to be used for calculations with crest values (I_{dN} , I_{max}). For calculations with root-mean-square values (rated data), the torque constant K_m must be multiplied by a factor of $\sqrt{2}$. ²⁾ Values determined according to EN 60034-1. Current and voltage specified as root-mean-square values. ³⁾ Without holding brake. ⁴⁾ Applicable to Bosch Rexroth cables. Rated according to VDE0298-4 (1992) and installation type B2 according to EN 60204-1 (1993) at an ambient temperature of 40 °C. ⁵⁾ Without blower unit. ⁶⁾ If the limits specified are exceeded, the performance data must be reduced if necessary. For reduction factors, refer to the chapter entitled "Environmental Conditions". ⁷⁾ Provided the power and encoder cables are mounted properly.						

Fig. 9-3: Technical data of MHD093A-058

Description	Symbol	Unit	MHD093B-024			
Type of cooling			Natural	Natural	Surface	Liquid
Motor overtemperature			60K	100 K	60 K/100	60 K/100
Electric parameters						
Characteristic motor speed	n_K	min^{-1}	2000			
Continuous torque at standstill	M_{dN}	Nm	17.5	20.0	26.3	33.3
Continuous current at standstill	I_{dN}	A	10.3	12.1	15.5	19.6
Peak current	I_{max}	A	46.4			
Torque constant at 20 °C ¹⁾	K_m	Nm/A	1.86			
Voltage constant at 20 °C	$K_{E(\text{eff})}$	V/1000min ⁻¹	162			
Winding resistance at 20 °C	R12	Ω	1.77			
Winding inductivity	L12	mH	13.1			
Number of pole pairs	p		4			
Rated data ²⁾						
Rated speed	n_N	min^{-1}	2000	2000	2000	2000
Rated torque	M_N	Nm	9.6	13.3	21.4	29.4
Rated current	I_N	A	4.0	5.7	8.9	12.2
Rated performance	P_N	kW	2.3	3.3	5.3	7.3
Rated voltage	U_N	V	334	340	354	371
Rated frequency	f_N	Hz	133	133	133	133
Mechanical parameters						
Moment of inertia of the rotor	J_M	kgm^2	25.5×10^{-4}			
Theoretical maximum torque	M_{max}	Nm	66.0			
Minimum strand cross-section ⁴⁾	S	mm^2	1.5	1.5	1.5	2.5
time constant	T_{th}	min	60	60	30	20
Maximum speed	n_{max}	min^{-1}	4000			
Motor mass ^{3) 5)}	m	kg	19.0			
Perm. stor. a. transport temperature	T_L	°C	-20 to +80			
Permissible ambient temperature ⁶⁾	T_{um}	°C	0 to 40			
Maximum setup height ⁶⁾	h	m	1000 above MSL			
Degree of protection ⁷⁾			IP65			
Insulation class (according to DIN VDE 0530 Part 1)			F			
Housing varnish			Prime coat black in a/w RAL 9005			
¹⁾ K_m is to be used for calculations with crest values (I_{dN} , I_{max}). For calculations with root-mean-square values (rated data), the torque constant K_m must be multiplied by a factor of $\sqrt{2}$. ²⁾ Values determined according to EN 60034-1. Current and voltage specified as root-mean-square values. ³⁾ Without holding brake. ⁴⁾ Applicable to Bosch Rexroth cables. Rated according to VDE0298-4 (1992) and installation type B2 according to EN 60204-1 (1993) at an ambient temperature of 40 °C. ⁵⁾ Without blower unit. ⁶⁾ If the limits specified are exceeded, the performance data must be reduced if necessary. For reduction factors, refer to the chapter entitled "Environmental Conditions". ⁷⁾ Provided the power and encoder cables are mounted properly.						

Fig. 9-4: Technical data of MHD093B-024

Description	Symbol	Unit	MHD093B-035			
Type of cooling			Natural	Natural	Surface	Liquid
Motor overtemperature			60K	100 K	60 K/100	60 K/100
Electric parameters						
Characteristic motor speed	n_K	min^{-1}	3000			
Continuous torque at standstill	M_{dN}	Nm	17.5	20.0	26.3	33.3
Continuous current at standstill	I_{dN}	A	12.8	15.1	19.2	24.3
Peak current	I_{max}	A	58.0			
Torque constant at 20 °C ¹⁾	K_m	Nm/A	1.5			
Voltage constant at 20 °C	$K_{E(\text{eff})}$	V/1000min ⁻¹	136			
Winding resistance at 20 °C	R12	Ω	1.26			
Winding inductivity	L12	mH	10.7			
Number of pole pairs	p		4			
Rated data ²⁾						
Rated speed	n_N	min^{-1}	2500	2500	2500	2500
Rated torque	M_N	Nm	8.8	14.5	20.9	29.1
Rated current	I_N	A	4.6	7.7	10.8	15.0
Rated performance	P_N	kW	2.7	4.7	6.6	9.3
Rated voltage	U_N	V	350	360	374	396
Rated frequency	f_N	Hz	167	167	167	167
Mechanical parameters						
Moment of inertia of the rotor	J_M	kgm^2	25.5×10^{-4}			
Theoretical maximum torque	M_{max}	Nm	66.0			
Minimum strand cross-section ⁴⁾	S	mm^2	1.5	1.5	1.5	2.5
time constant	T_{th}	min	60	60	30	20
Maximum speed	n_{max}	min^{-1}	4500			
Motor mass ^{3) 5)}	m	kg	19.0			
Perm. stor. a. transport temperature	T_L	°C	-20 to +80			
Permissible ambient temperature ⁶⁾	T_{um}	°C	0 to 40			
Maximum setup height ⁶⁾	h	m	1000 above MSL			
Degree of protection ⁷⁾			IP65			
Insulation class (according to DIN VDE 0530 Part 1)			F			
Housing varnish			Prime coat black in a/w RAL 9005			
¹⁾ K_m is to be used for calculations with crest values (I_{dN} , I_{max}). For calculations with root-mean-square values (rated data), the torque constant K_m must be multiplied by a factor of $\sqrt{2}$. ²⁾ Values determined according to EN 60034-1. Current and voltage specified as root-mean-square values. ³⁾ Without holding brake. ⁴⁾ Applicable to Bosch Rexroth cables. Rated according to VDE0298-4 (1992) and installation type B2 according to EN 60204-1 (1993) at an ambient temperature of 40 °C. ⁵⁾ Without blower unit. ⁶⁾ If the limits specified are exceeded, the performance data must be reduced if necessary. For reduction factors, refer to the chapter entitled "Environmental Conditions". ⁷⁾ Provided the power and encoder cables are mounted properly.						

Fig. 9-5: Technical data of MHD093B-035

Description	Symbol	Unit	MHD093B-058			
			Natural 60K	Natural 100 K	Surface 60 K/100	Liquid 60 K/100
Type of cooling						
Motor overtemperature			60K	100 K	60 K/100	60 K/100
Electric parameters						
Characteristic motor speed	n_K	min^{-1}	4000			
Continuous torque at standstill	M_{dN}	Nm	17.5	20.0	26.3	33.3
Continuous current at standstill	I_{dN}	A	22.5	26.0	33.8	42.8
Peak current	I_{max}	A	101.2			
Torque constant at 20 °C ¹⁾	K_m	Nm/A	0.87			
Voltage constant at 20 °C	$K_{E(\text{eff})}$	V/1000min ⁻¹	79.0			
Winding resistance at 20 °C	R12	Ω	0.44			
Winding inductivity	L12	mH	3.2			
Number of pole pairs	p		4			
Rated data ²⁾						
Rated speed	n_N	min^{-1}	2500	4000	4000	4000
Rated torque	M_N	Nm	5.4	8.1	15.0	24.7
Rated current	I_N	A	4.9	7.5	13.6	22.5
Rated performance	P_N	kW	1.7	4.1	7.6	12.7
Rated voltage	U_N	V	200	322	330	347
Rated frequency	f_N	Hz	167	267	267	267
Mechanical parameters						
Moment of inertia of the rotor	J_M	kgm^2	25.5×10^{-4}			
Theoretical maximum torque	M_{max}	Nm	66.0			
Minimum strand cross-section ⁴⁾	S	mm^2	2.5	2.5	4.0	6.0
time constant	T_{th}	min	60	60	30	20
Maximum speed	n_{max}	min^{-1}	6000			
Motor mass ^{3) 5)}	m	kg	19.0			
Perm. stor. a. transport temperature	T_L	°C	-20 to +80			
Permissible ambient temperature ⁶⁾	T_{um}	°C	0 to 40			
Maximum setup height ⁶⁾	h	m	1000 above MSL			
Degree of protection ⁷⁾			IP65			
Insulation class (according to DIN VDE 0530 Part 1)			F			
Housing varnish			Prime coat black in a/w RAL 9005			
¹⁾ K_m is to be used for calculations with crest values (I_{dN} , I_{max}). For calculations with root-mean-square values (rated data), the torque constant K_m must be multiplied by a factor of $\sqrt{2}$. ²⁾ Values determined according to EN 60034-1. Current and voltage specified as root-mean-square values. ³⁾ Without holding brake. ⁴⁾ Applicable to Bosch Rexroth cables. Rated according to VDE0298-4 (1992) and installation type B2 according to EN 60204-1 (1993) at an ambient temperature of 40 °C. ⁵⁾ Without blower unit. ⁶⁾ If the limits specified are exceeded, the performance data must be reduced if necessary. For reduction factors, refer to the chapter entitled "Environmental Conditions". ⁷⁾ Provided the power and encoder cables are mounted properly.						

Fig. 9-6: Technical data of MHD093B-058

Description	Symbol	Unit	MHD093C-024			
			Natural 60K	Natural 100 K	Surface 60 K/100	Liquid 60 K/100
Type of cooling						
Motor overtemperature			60K	100 K	60 K/100	60 K/100
Electric parameters						
Characteristic motor speed	n_K	min^{-1}	2000			
Continuous torque at standstill	M_{dN}	Nm	23.0	28.0	34.5	43.7
Continuous current at standstill	I_{dN}	A	14.1	17.8	21.6	26.8
Peak current	I_{max}	A	63.5			
Torque constant at 20 °C ¹⁾	K_m	Nm/A	1.79			
Voltage constant at 20 °C	$K_{E(\text{eff})}$	V/1000min ⁻¹	156			
Winding resistance at 20 °C	R12	Ω	1.16			
Winding inductivity	L12	mH	9.15			
Number of pole pairs	p		4			
Rated data ²⁾						
Rated speed	n_N	min^{-1}	2000	2000	2000	2000
Rated torque	M_N	Nm	11.4	17.4	27.4	38.2
Rated current	I_N	A	4.9	7.8	12.1	16.6
Rated performance	P_N	kW	2.7	4.4	6.7	9.5
Rated voltage	U_N	V	320	327	339	355
Rated frequency	f_N	Hz	133	133	133	133
Mechanical parameters						
Moment of inertia of the rotor	J_M	kgm^2	30.0×10^{-4}			
Theoretical maximum torque	M_{max}	Nm	88.0			
Minimum strand cross-section ⁴⁾	S	mm^2	1.5	2.5	2.5	4.0
time constant	T_{th}	min	75	75	35	25
Maximum speed	n_{max}	min^{-1}	4000			
Motor mass ^{3) 5)}	m	kg	23.5			
Perm. stor. a. transport temperature	T_L	°C	-20 to +80			
Permissible ambient temperature ⁶⁾	T_{um}	°C	0 to 40			
Maximum setup height ⁶⁾	h	m	1000 above MSL			
Degree of protection ⁷⁾			IP65			
Insulation class (according to DIN VDE 0530 Part 1)			F			
Housing varnish			Prime coat black in a/w RAL 9005			
¹⁾ K_m is to be used for calculations with crest values (I_{dN} , I_{max}). For calculations with root-mean-square values (rated data), the torque constant K_m must be multiplied by a factor of $\sqrt{2}$. ²⁾ Values determined according to EN 60034-1. Current and voltage specified as root-mean-square values. ³⁾ Without holding brake. ⁴⁾ Applicable to Bosch Rexroth cables. Rated according to VDE0298-4 (1992) and installation type B2 according to EN 60204-1 (1993) at an ambient temperature of 40 °C. ⁵⁾ Without blower unit. ⁶⁾ If the limits specified are exceeded, the performance data must be reduced if necessary. For reduction factors, refer to the chapter entitled "Environmental Conditions". ⁷⁾ Provided the power and encoder cables are mounted properly.						

Fig. 9-7: Technical data of MHD093B-058

Description	Symbol	Unit	MHD093C-035			
Type of cooling			Natural	Natural	Surface	Liquid
Motor overtemperature			60K	100 K	60 K/100	60 K/100
Electric parameters						
Characteristic motor speed	n_K	min^{-1}	3000			
Continuous torque at standstill	M_{dN}	Nm	23.0	28.0	34.5	43.7
Continuous current at standstill	I_{dN}	A	18.5	24.5	27.8	35.2
Peak current	I_{max}	A	83.5			
Torque constant at 20 °C ¹⁾	K_m	Nm/A	1.39			
Voltage constant at 20 °C	$K_{E(\text{eff})}$	V/1000min ⁻¹	126.4			
Winding resistance at 20 °C	R12	Ω	0.79			
Winding inductivity	L12	mH	6.2			
Number of pole pairs	p		4			
Rated data ²⁾						
Rated speed	n_N	min^{-1}	2500	2500	2500	2500
Rated torque	M_N	Nm	9.1	17.9	26.2	37.2
Rated current	I_N	A	5.2	11.8	14.9	21.2
Rated performance	P_N	kW	2.9	6.2	8.5	12.2
Rated voltage	U_N	V	322	332	342	360
Rated frequency	f_N	Hz	167	167	167	167
Mechanical parameters						
Moment of inertia of the rotor	J_M	kgm^2	30.0×10^{-4}			
Theoretical maximum torque	M_{max}	Nm	88.0			
Minimum strand cross-section ⁴⁾	S	mm^2	1.5	2.5	4.0	4.0
time constant	T_{th}	min	75	75	35	25
Maximum speed	n_{max}	min^{-1}	4500			
Motor mass ^{3) 5)}	m	kg	23.5			
Perm. stor. a. transport temperature	T_L	°C	-20 to +80			
Permissible ambient temperature ⁶⁾	T_{um}	°C	0 to 40			
Maximum setup height ⁶⁾	h	m	1000 above MSL			
Degree of protection ⁷⁾			IP65			
Insulation class (according to DIN VDE 0530 Part 1)			F			
Housing varnish			Prime coat black in a/w RAL 9005			
¹⁾ K_m is to be used for calculations with crest values (I_{dN} , I_{max}). For calculations with root-mean-square values (rated data), the torque constant K_m must be multiplied by a factor of $\sqrt{2}$. ²⁾ Values determined according to EN 60034-1. Current and voltage specified as root-mean-square values. ³⁾ Without holding brake. ⁴⁾ Applicable to Bosch Rexroth cables. Rated according to VDE0298-4 (1992) and installation type B2 according to EN 60204-1 (1993) at an ambient temperature of 40 °C. ⁵⁾ Without blower unit. ⁶⁾ If the limits specified are exceeded, the performance data must be reduced if necessary. For reduction factors, refer to the chapter entitled "Environmental Conditions". ⁷⁾ Provided the power and encoder cables are mounted properly.						

Fig. 9-8: Technical data of MHD093C-035

Description	Symbol	Unit	MHD093C-058			
Type of cooling			Natural	Natural	Surface	Liquid
Motor overtemperature			60K	100 K	60 K/100	60 K/100
Electric parameters						
Characteristic motor speed	n_K	min^{-1}	4000			
Continuous torque at standstill	M_{dN}	Nm	23.0	28.0	34.5	43.7
Continuous current at standstill	I_{dN}	A	28.3	34.5	42.5	53.8
Peak current	I_{max}	A	127.4			
Torque constant at 20 °C ¹⁾	K_m	Nm/A	0.91			
Voltage constant at 20 °C	$K_{E(\text{eff})}$	V/1000min ⁻¹	82.7			
Winding resistance at 20 °C	R12	Ω	0.32			
Winding inductivity	L12	mH	2.6			
Number of pole pairs	p		4			
Rated data ²⁾						
Rated speed	n_N	min^{-1}	2000	3500	3500	3500
Rated torque	M_N	Nm	7.9	9.1	19.2	32.0
Rated current	I_N	A	6.9	7.9	16.7	27.9
Rated performance	P_N	kW	2.0	4.0	8.5	14.4
Rated voltage	U_N	V	168	293	302	317
Rated frequency	f_N	Hz	133	233	233	233
Mechanical parameters						
Moment of inertia of the rotor	J_M	kgm^2	30.0×10^{-4}			
Theoretical maximum torque	M_{max}	Nm	88.0			
Minimum strand cross-section ⁴⁾	S	mm^2	2.5	2.5	6.0	6.0
time constant	T_{th}	min	75	75	35	25
Maximum speed	n_{max}	min^{-1}	6000			
Motor mass ^{3) 5)}	m	kg	23.5			
Perm. stor. a. transport temperature	T_L	°C	-20 to +80			
Permissible ambient temperature ⁶⁾	T_{um}	°C	0 to 40			
Maximum setup height ⁶⁾	h	m	1000 above MSL			
Degree of protection ⁷⁾			IP65			
Insulation class (according to DIN VDE 0530 Part 1)			F			
Housing varnish			Prime coat black in a/w RAL 9005			
¹⁾ K_m is to be used for calculations with crest values (I_{dN} , I_{max}). For calculations with root-mean-square values (rated data), the torque constant K_m must be multiplied by a factor of $\sqrt{2}$. ²⁾ Values determined according to EN 60034-1. Current and voltage specified as root-mean-square values. ³⁾ Without holding brake. ⁴⁾ Applicable to Bosch Rexroth cables. Rated according to VDE0298-4 (1992) and installation type B2 according to EN 60204-1 (1993) at an ambient temperature of 40 °C. ⁵⁾ Without blower unit. ⁶⁾ If the limits specified are exceeded, the performance data must be reduced if necessary. For reduction factors, refer to the chapter entitled "Environmental Conditions". ⁷⁾ Provided the power and encoder cables are mounted properly.						

Fig. 9-9: Technical data of MHD093C-058

Holding brake

Description	Symbol	Unit	Holding brake 1	Holding brake 2
Motor type			MHD093	MHD093
Holding torque	M_4	Nm	22.0	32.0
Rated voltage	U_N	V	DC 24 ± 10%	DC 24 ± 10%
Rated current	I_N	A	0.71	0.93
Moment of inertia	J_B	Kgm ²	3.6×10^{-4}	12.4×10^{-4}
Connection time	t_1	ms	25	15
Disconnection time	T_2	ms	50	115
Mass	m_B	kg	1.1	2.4

Fig. 9-10: Technical data of MHD093 holding brake (optional)

Technical Data liquid coolant

Description	Symbol	Unit	Data	
			MHD093B...	MHD093C...
motor type			MHD093B...	MHD093C...
Nominal power loss	P_{vN}	W	900	1000
Coolant inlet temperature ¹⁾	ϑ_{ein}	°C	+10 ... +40	
Coolant temperature raise at P_{vN}	$\Delta\vartheta_N$	°C	10	
Minimum necessary coolant discharge at $\Delta\vartheta_N$ ²⁾	Q_N	l/min	1.3	1.4
Pressure decrease at Q_N ²⁾³⁾	Δp_N	bar	0.6	0.7
Maximum system pressure	p_{max}	bar	3.0	
Volume liquid cooling duct	V	l	0.05	0.06
pH-value coolant			6 - 8	
Materials with coolant contact			Description	
Flange, end shield			Al Mg 5 F32	
Profile			Al Mg Si 0,5 F22	
O-ring			Viton	
1) Notice the combination between coolant inlet temperature and real environmental temperature: the coolant inlet temperature should be max. 5°C under the real environmental temperature (otherwise danger of condensation exists)! 2) at coolant water 3) for deviating discharge values notice the discharge diagram (see chapter 16.5)				

Fig. 9-11: Technical data liquid coolant MHD093

9.2 Type Code – Ordering Name

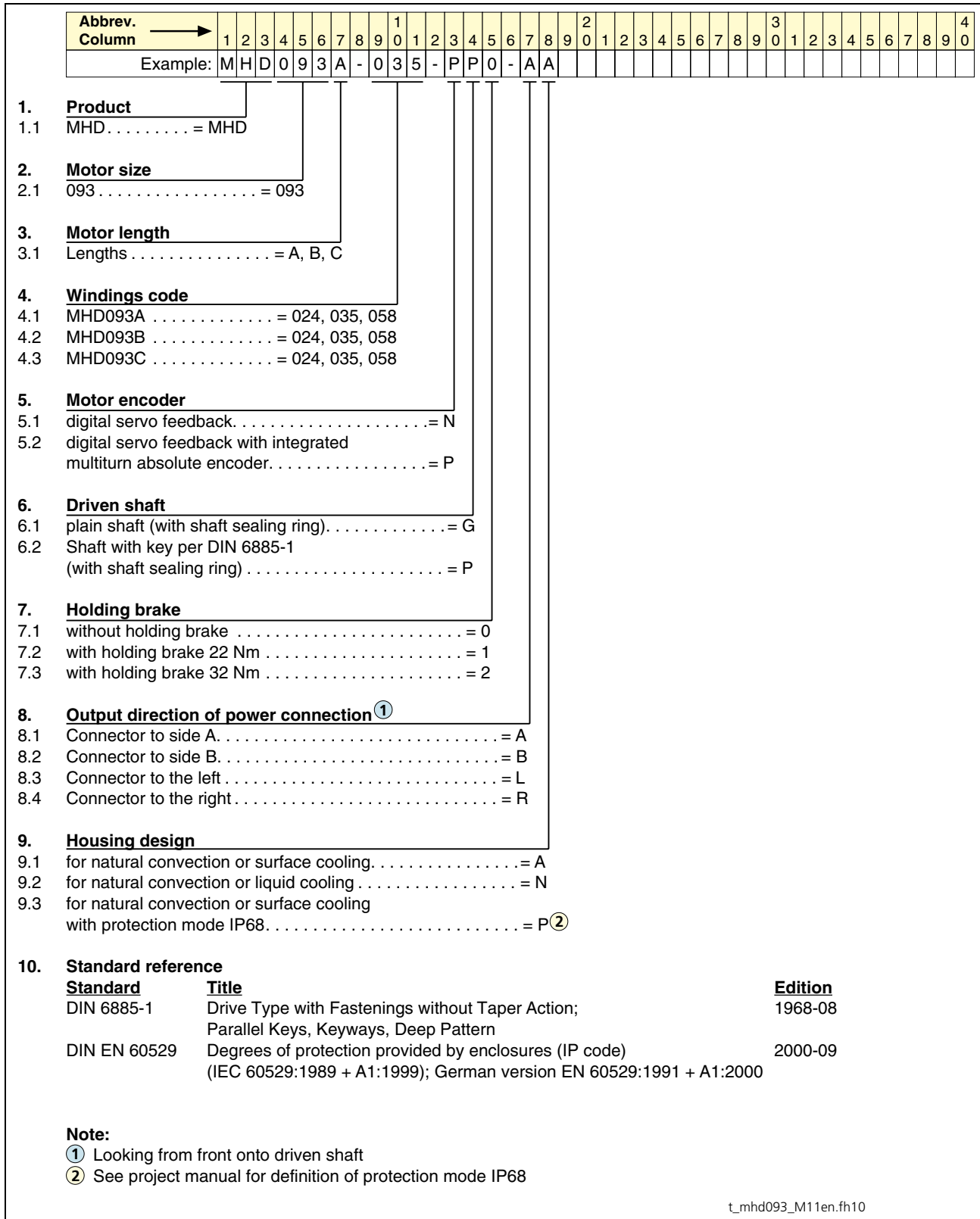
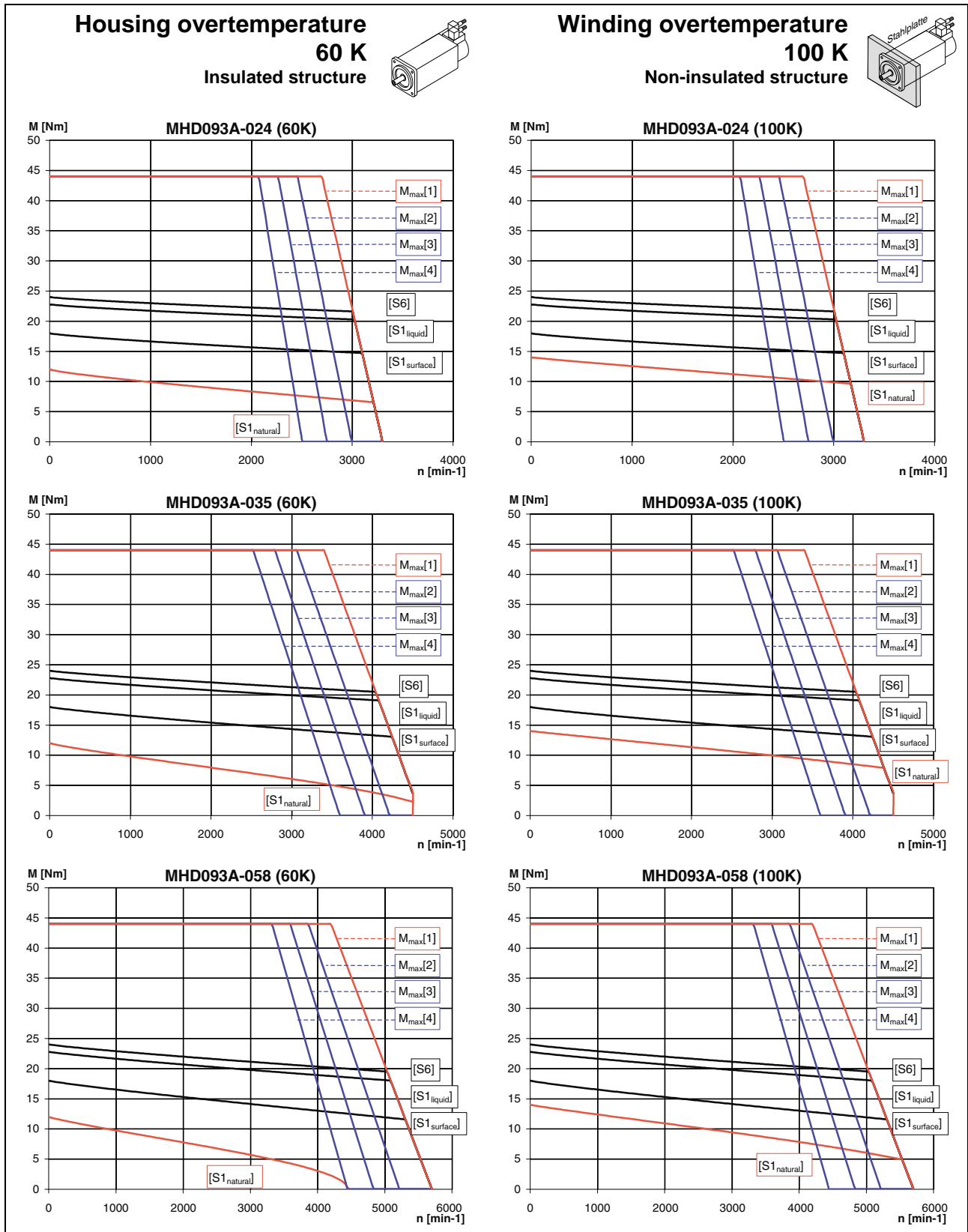
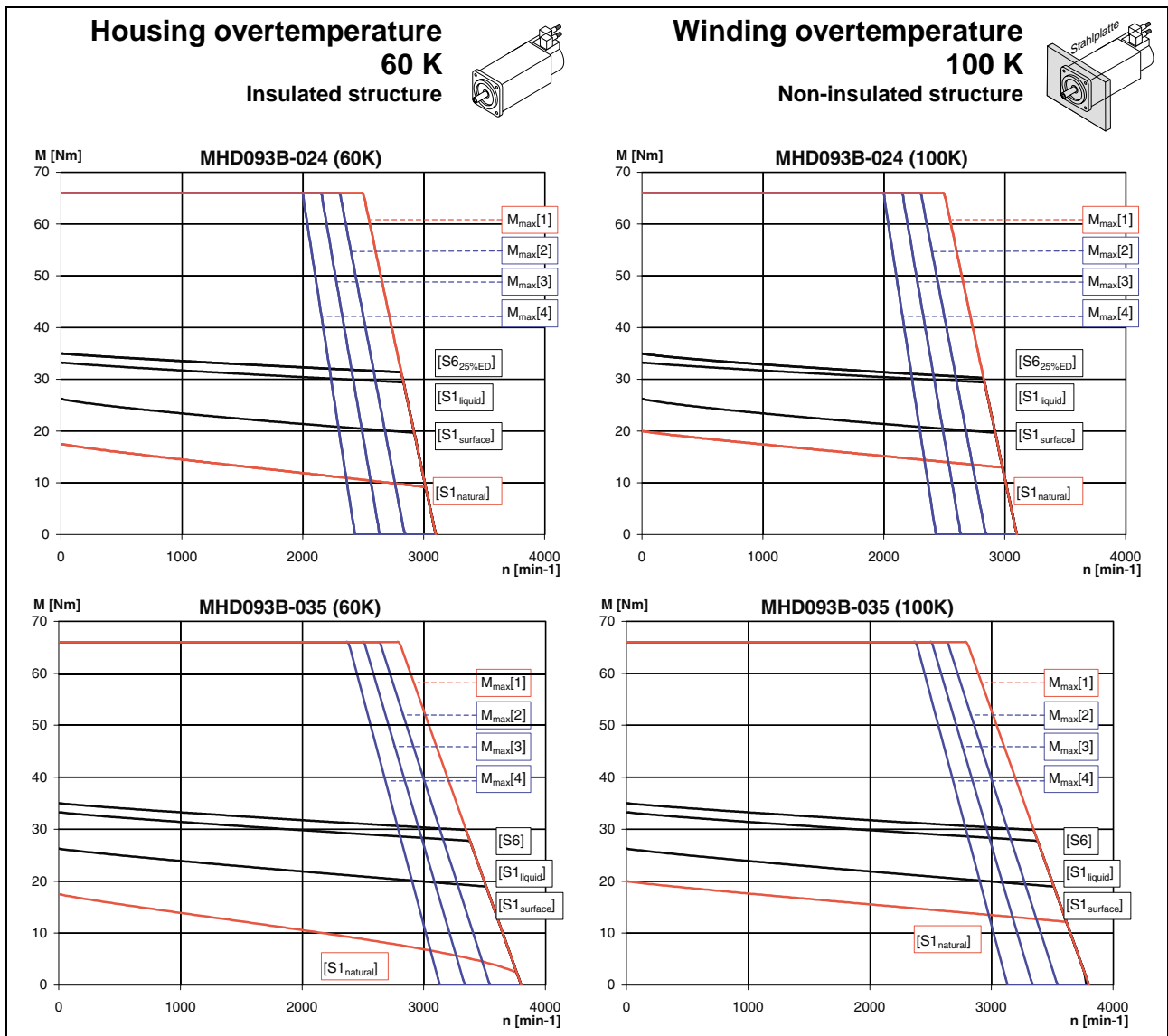

Fig. 9-12: type code MHD093

9.3 Speed-Torque Curves





[S1_{natural}]: M_{dN} Natural conv. (S1 continuous operation)
 [S1_{surface}]: M_{dN} Surface cooling (S1 continuous operation)
 [S1_{liquid}]: M_{dN} Liquid cooling (S1 continuous operation)
 [S6]: M_{KB} (S6 intermittent operation)
M_{max}[1]: HDS to HVR
M_{max}[2]: HDS to HVE or DKCxx.3 with a power connection of 3 x AC 480 V
M_{max}[3]: HDS to HVE or DKCxx.3 with a power connection of 3 x AC 440 V
M_{max}[4]: HDS to HVE or DKCxx.3 with a power connection of 3 x AC 400 V

Fig. 9-13: Characteristic curves

**Housing overtemperature
60 K
Insulated structure**

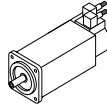

**Winding overtemperature
100 K
Non-insulated structure**

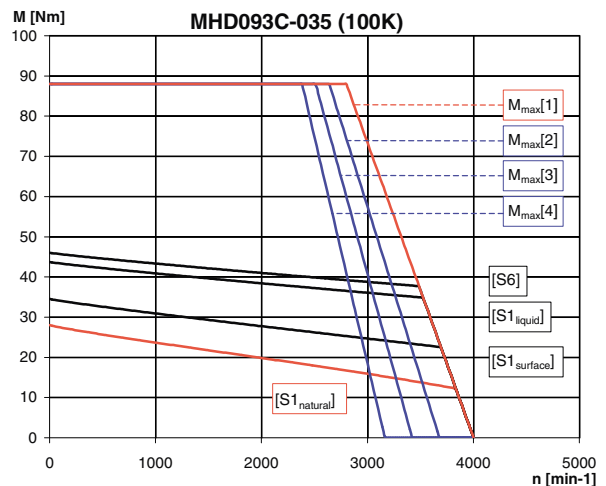
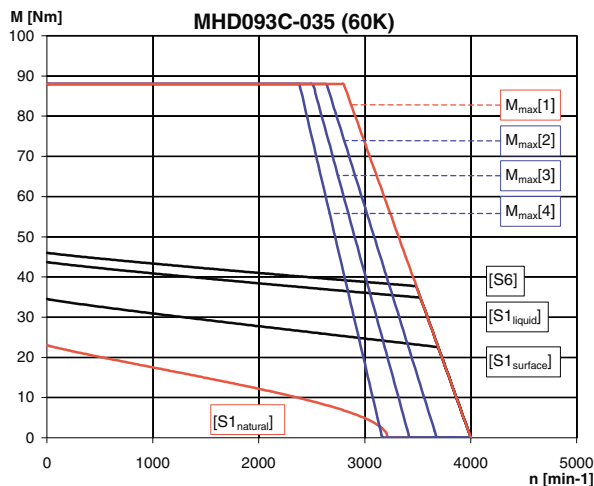
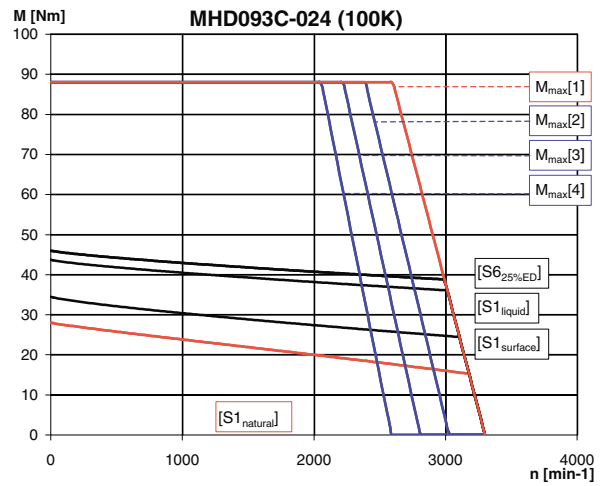
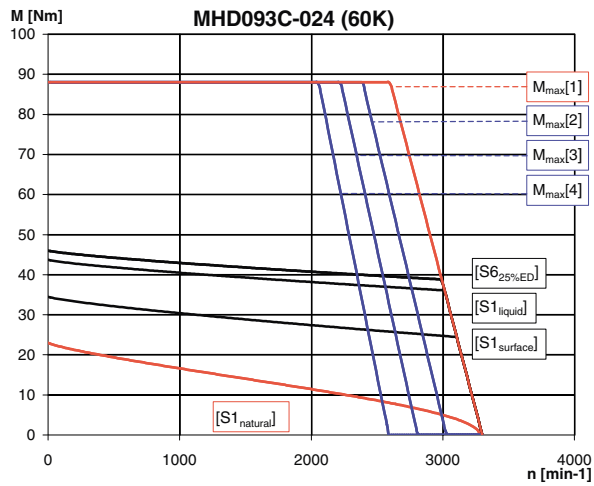
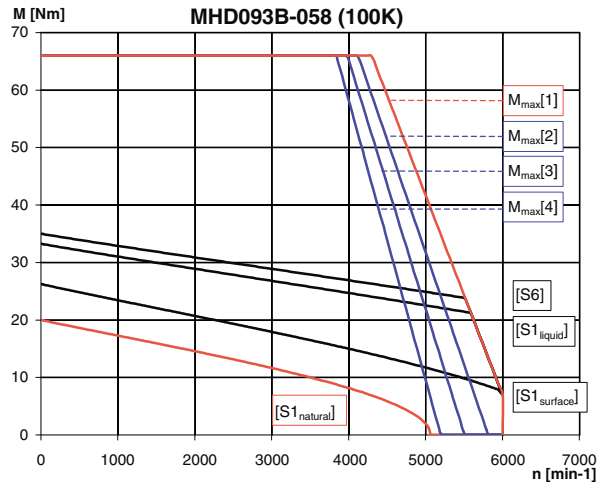
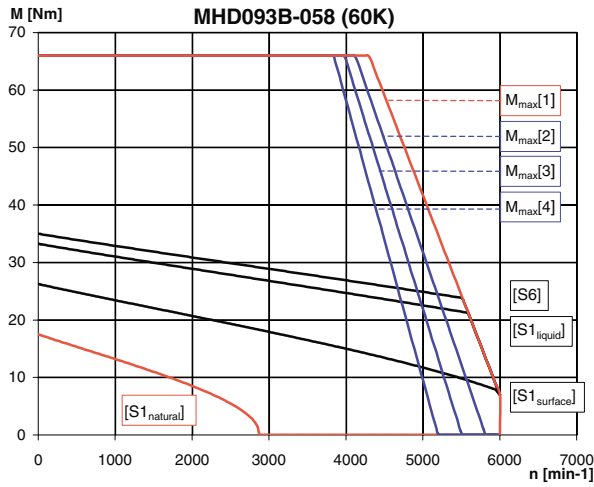
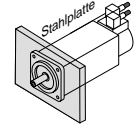

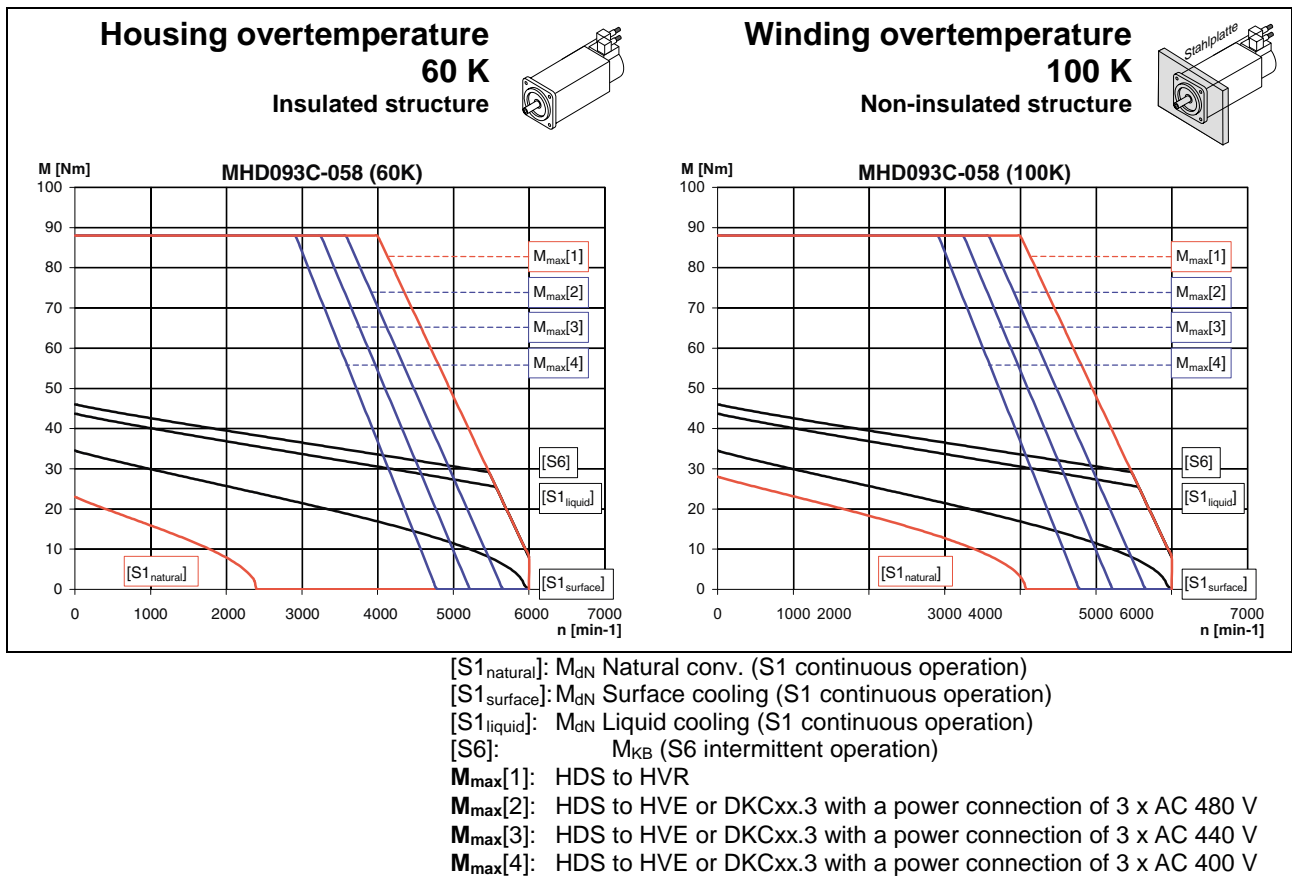
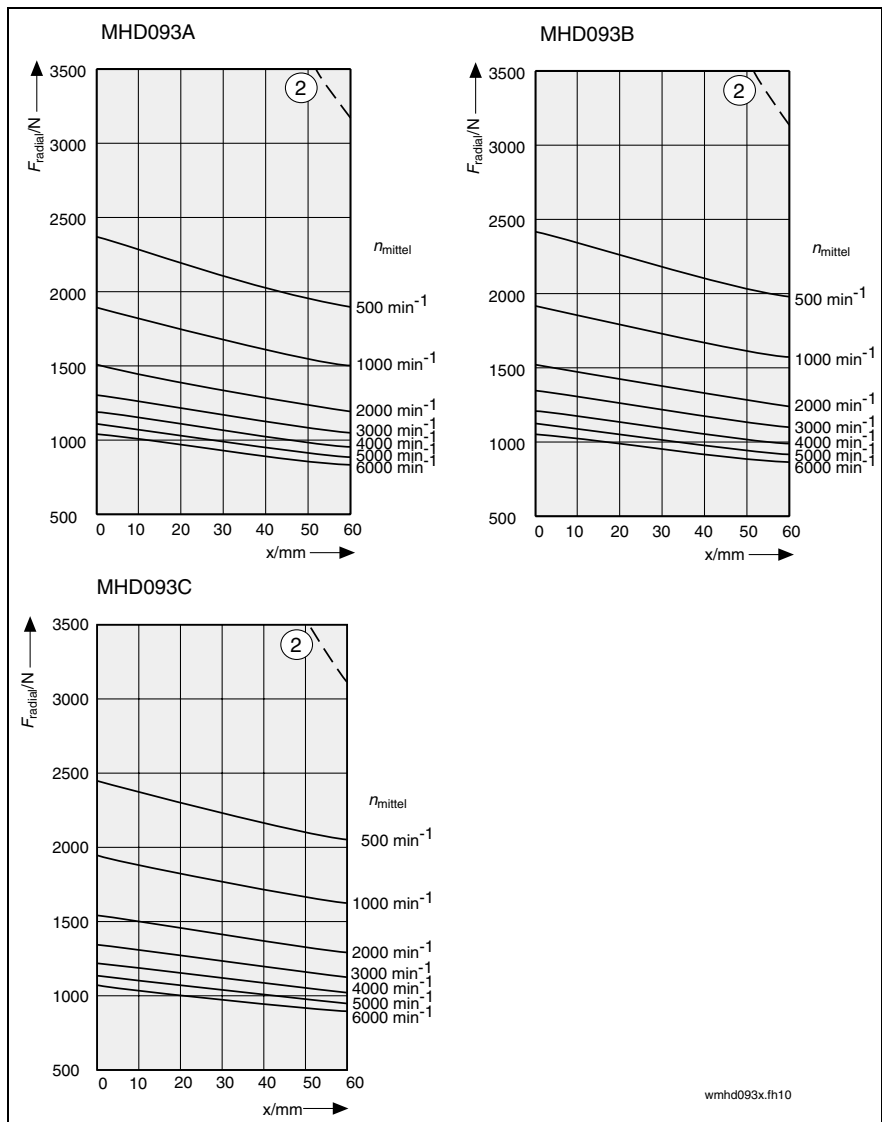

Fig. 9-14: Characteristic curves

9.4 Shaft loads

Permissible maximum radial force $F_{\text{radial_max}}$ and permissible radial force F_{radial}

For explanations refer to Chapter 16.



- (1): $F_{\text{radial_max}}$ (plain shaft)
- (2): $F_{\text{radial_max}}$ (shaft with keyway)

Fig. 9-15: MHD093: Permissible maximum radial force $F_{\text{radial_max}}$ and permissible radial force F_{radial}

Permissible axial force F_{axial}

$$F_{\text{axial}} = x \cdot F_{\text{radial}}$$

- x : 0.24 for MHD093A, -B, -C
- F_{axial} : permissible axial force in N
- F_{radial} : permissible radial force in N

Fig. 9-16: MHD093: permissible axial force F_{axial}

9.5 Dimensional Details (Standard Cooling)

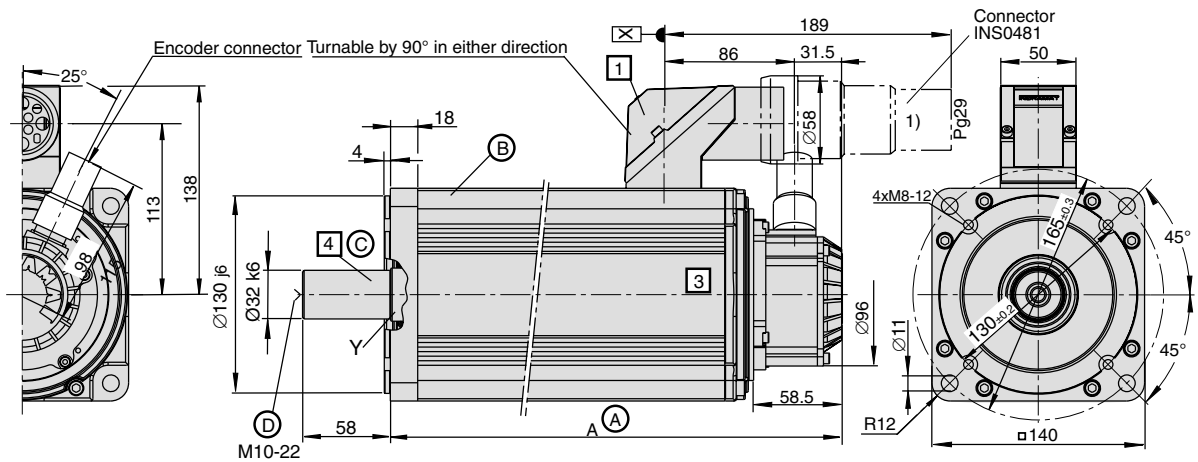

1) Connector not included in the scope of motor delivery

Detail Y:

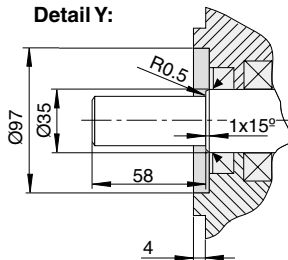

Options

1) Output direction of power connector

The output direction of the power connector must be selected when ordering. The following output directions are possible

- to side A
- to side B
- to the right
- to the left

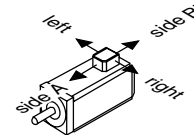

The drawing shows the output direction upon delivery, i.e. to side B. The measures in case of a different output direction are obtained by turning the connector housing theoretically around the X-axis.

A) Size table

Frame size	Meas. A
MHD093A	316
MHD093B	356
MHD093C	396

B) Motor design according to EN 60034-7, 1996-06, B5 for all installation positions

C)

- Flange according to DIN 42948, ed. 11.65
- Positional accuracy with regard to true running, axial running an coaxiality to the shaft according to DIN 42955 Tolerance Class R, ed. 12.81

D)

- Shaft end according to DIN 748 Part 3, ed. 07.75, cylindrical
- Center hole DS M10 according to DIN 332 Part 2, ed. 05.83
- Max. tightening torque for screw 25.0 Nm
- Vibration severity grade N according to DIN VDE 0530 Part 14, ed. 02.93

2) Motor encoder

- Digital servo feedback (HSF)
 - Digital servo feedback (HSF) with integrated multiturn absolute encoder
- Measures are identical.

3) Holding brake

- Without holding brake
 - With holding brake
- Measures are identical.

4) Output shaft

- Plain shaft (preferred type)
- With keyway according to DIN 6885 Sheet 1, ed. 08.68 (Caution! Balanced with entire keyway!)

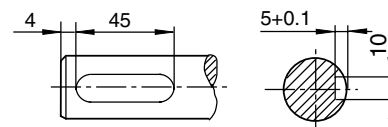

Matching keyway, DIN 6885-A 10 x 8 x 45, Not part of general delivery.

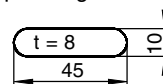

M02MH093_A.fh10

Fig. 9-17: Dimensional details of MHD093-.....-A

9.6 Blower Units

MHD motors can also be delivered with optional blower units. Please refer to the “Surface” column of the data sheets for performance data of surface-cooled motors. The mechanical dimensions of the blower units are represented in the dimension drawings. The possibilities of combining motor and blower unit and the technical data of the blowers are represented in the table below.

Motor	Ordering name of blower unit			
	LEMD-RB090B1XX	LEMD-RB090B2XX	LEMH-AB093B1XX	LEMH-AB093B2XX
MHD093A-xxx-xxx-Axxxx	---	---	x	x
MHD093B-xxx-xxx-Axxxx	x	x	x	x
MHD093C-xxx-xxx-Axxxx	x	x	x	x
--- Blower installation <u>not</u> possible; x Blower installation possible				

Technical data of blower unit			LEMD-RB090B1XX	LEMD-RB090B2XX	LEMH-AB093B1XX	LEMH-AB093B2XX
Description	Symbol	Unit				
Type of cooling			Radial		axial	
Air flow			B ⇒A blowing		B ⇒A blowing	
Rated voltage	U_n	V	230 V, ±15% 50 / 60 Hz	115 V, ±10% 50 / 60 Hz	230 V, ±15% 50 / 60 Hz	115 V, ±10% 50 / 60 Hz
Power consumption	S_n	VA	45 / 43	40 / 39	45 / 43	40 / 39
Rated current	I	A	0.31 / 0.25	0.53 / 0.46	0.31 / 0.25	0.53 / 0.46
Mean air volume	V	m ³ /h	340	390	340	390
Blower unit mass	m_L	kg	1.2	1.1	1.2	1.1
Noise level		dB(A)	48 / 52	48 / 52	48 / 52	48 / 52

Fig. 9-18: Technical data of MHD093 blower units (optional)

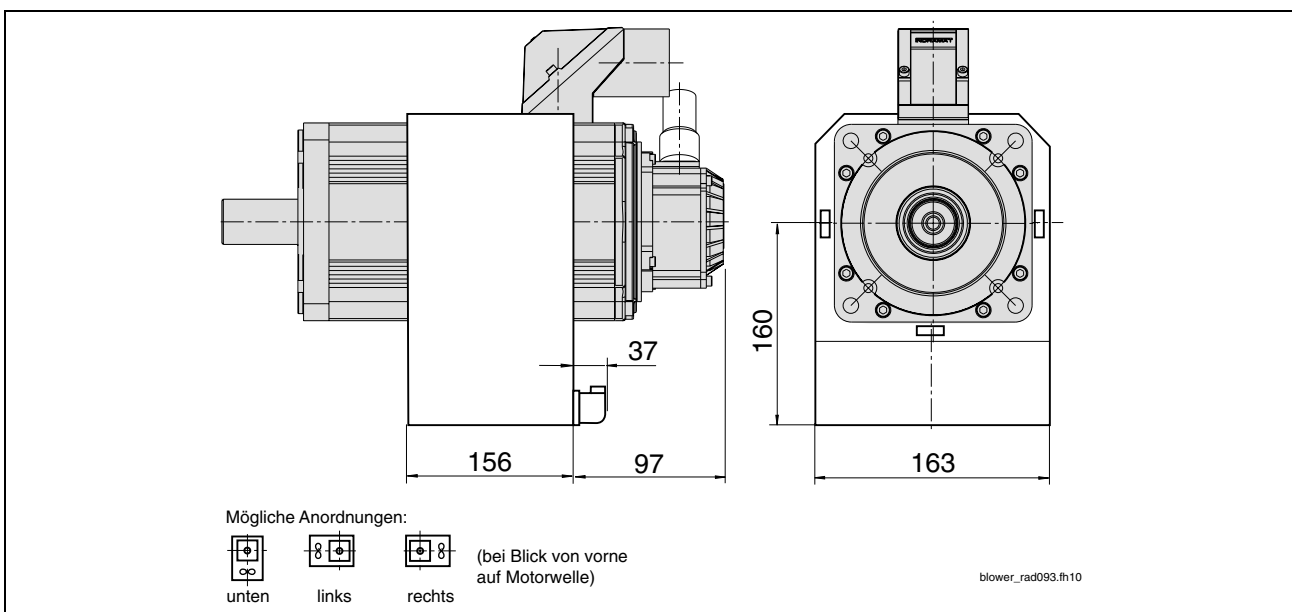

Fig. 9-19: Dimensional details of MHD093 with radial blower

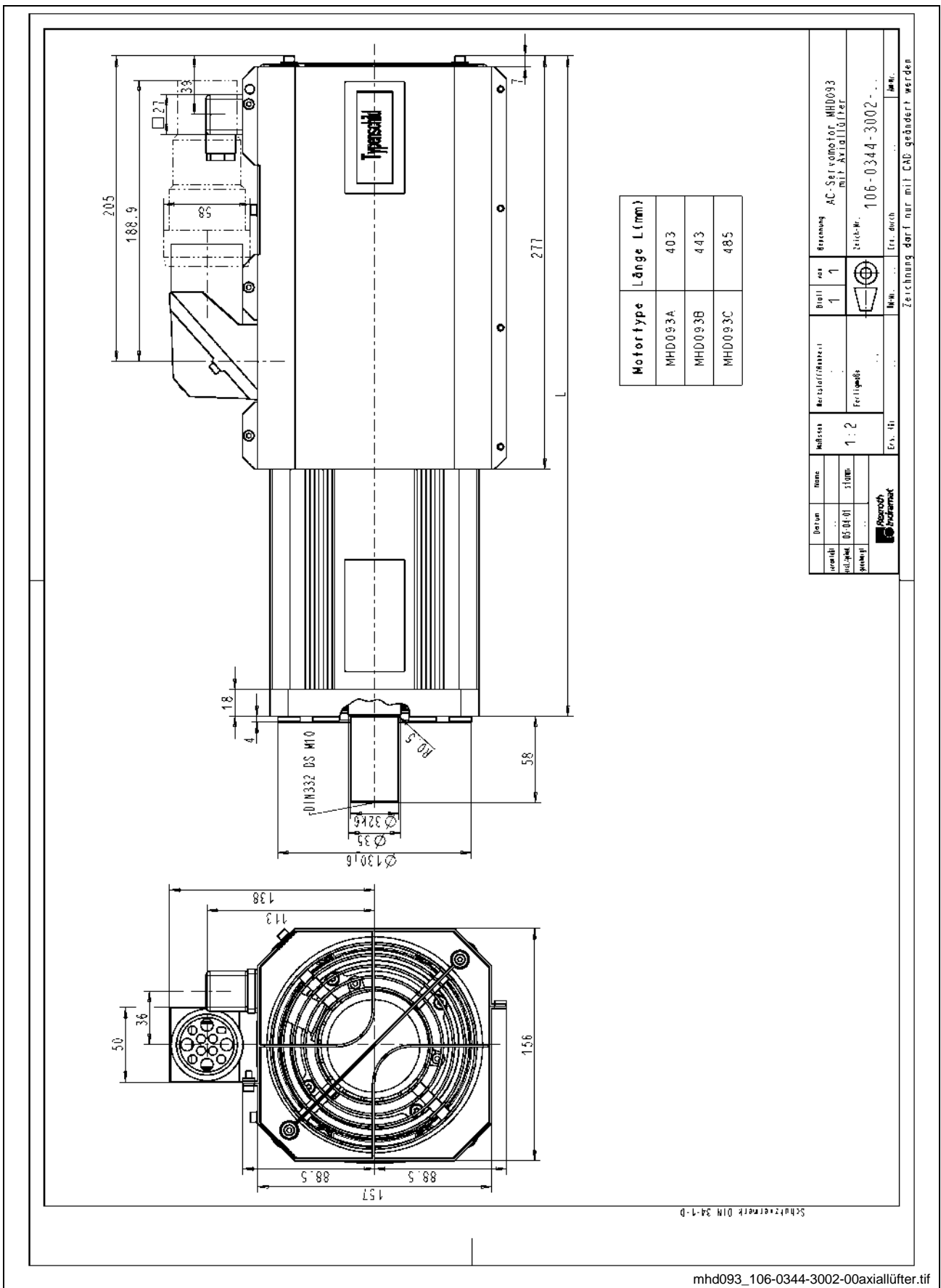

Fig. 9-20: Dimensional details of MHD093 with axial blower

9.7 Dimensional Details (Liquid Cooling)

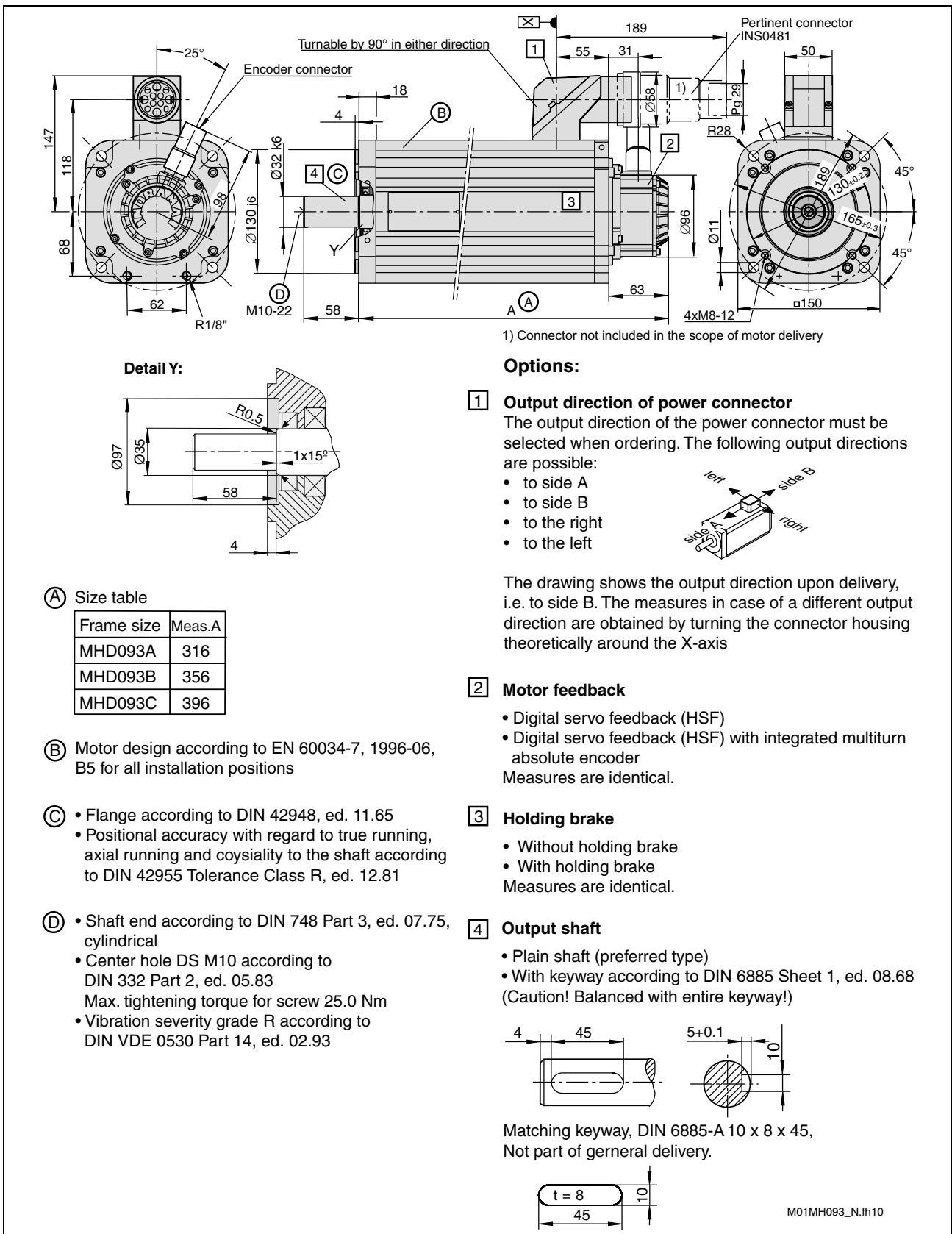

Fig. 9-21: Dimensional details of MHD093-.....-N

10 MHD095

10.1 Technical data

Description	Symbol	Unit	MHD095A-024			
			Natural 60K	Natural 100 K	Surface 60 K/100	Liquid 60 K/100
Type of cooling			Natural 60K	Natural 100 K	Surface 60 K/100	Liquid 60 K/100
Motor overtemperature						
Electric parameters						
Characteristic motor speed	n_K	min^{-1}	2000			
Continuous torque at standstill	M_{dN}	Nm	12.0	13.5	18.0	
Continuous current at standstill	I_{dN}	A	8.3	9.4	12.5	
Peak current	I_{max}	A	37.4			
Torque constant at 20 °C ¹⁾	K_m	Nm/A	1.6			
Voltage constant at 20 °C	$K_{E(eff)}$	V/1000min ⁻¹	139.1			
Winding resistance at 20 °C	R12	Ω	2.95			
Winding inductivity	L12	mH	16.0			
Number of pole pairs	p		4			
Rated data ²⁾						
Rated speed	n_N	min^{-1}	3000	3000	3000	
Rated torque	M_N	Nm	6.0	9.2	14.3	
Rated current	I_N	A	2.9	4.5	7.0	not
Rated performance	P_N	kW	2.2	3.4	5.3	available
Rated voltage	U_N	V	430	440	460	
Rated frequency	f_N	Hz	200	200	200	
Mechanical parameters						
Moment of inertia of the rotor	J_M	kgm^2	35.2×10^{-4}			
Theoretical maximum torque	M_{max}	Nm	44.0			
Minimum strand cross-section ⁴⁾	S	mm^2	1.5	1.5	1.5	
time constant	T_{th}	min	40	40	20	
Maximum speed	n_{max}	min^{-1}	4000			
Motor mass ^{3) 5)}	m	kg	14.5			
Perm. stor. a. transport temperature	T_L	°C	-20 to +80			
Permissible ambient temperature ⁶⁾	T_{um}	°C	0 to 40			
Maximum setup height ⁶⁾	h	m	1000 above MSL			
Degree of protection ⁷⁾			IP65			
Insulation class (according to DIN VDE 0530 Part 1)			F			
Housing varnish			Prime coat black in a/w RAL 9005			
¹⁾ K_m is to be used for calculations with crest values (I_{dN} , I_{max}). For calculations with root-mean-square values (rated data), the torque constant K_m must be multiplied by a factor of $\sqrt{2}$. ²⁾ Values determined according to EN 60034-1. Current and voltage specified as root-mean-square values. ³⁾ Without holding brake. ⁴⁾ Applicable to Bosch Rexroth cables. Rated according to VDE0298-4 (1992) and installation type B2 according to EN 60204-1 (1993) at an ambient temperature of 40 °C. ⁵⁾ Without blower unit. ⁶⁾ If the limits specified are exceeded, the performance data must be reduced if necessary. For reduction factors, refer to the chapter entitled "Environmental Conditions". ⁷⁾ Provided the power and encoder cables are mounted properly.						

Fig. 10-1: Technical data of MHD095A-024

Description	Symbol	Unit	MHD095A-035			
Type of cooling			Natural	Natural	Surface	Liquid
Motor overtemperature			60K	100 K	60 K/100	60 K/100
Electric parameters						
Characteristic motor speed	n_K	min^{-1}	3000			
Continuous torque at standstill	M_{dN}	Nm	12.0	13.5	18.0	
Continuous current at standstill	I_{dN}	A	11.6	13.1	17.4	
Peak current	I_{max}	A	52.2			
Torque constant at 20 °C ¹⁾	K_m	Nm/A	1.14			
Voltage constant at 20 °C	$K_{E(\text{eff})}$	V/1000 min^{-1}	99.1			
Winding resistance at 20 °C	R12	Ω	1.58			
Winding inductivity	L12	mH	8.8			
Number of pole pairs	p		4			
Rated data ²⁾						
Rated speed	n_N	min^{-1}	3000	3000	3000	
Rated torque	M_N	Nm	5.9	9.1	14.2	
Rated current	I_N	A	4.0	6.2	9.7	not
Rated performance	P_N	kW	2.1	3.3	5.3	available
Rated voltage	U_N	V	307	315	330	
Rated frequency	f_N	Hz	200	200	200	
Mechanical parameters						
Moment of inertia of the rotor	J_M	kgm^2	35.2×10^{-4}			
Theoretical maximum torque	M_{max}	Nm	44.0			
Minimum strand cross-section ⁴⁾	S	mm^2	1.5	1.5	1.5	
time constant	T_{th}	min	40	40	20	
Maximum speed	n_{max}	min^{-1}	4500			
Motor mass ^{3) 5)}	m	kg	14.5			
Perm. stor. a. transport temperature	T_L	°C	-20 to +80			
Permissible ambient temperature ⁶⁾	T_{um}	°C	0 to 40			
Maximum setup height ⁶⁾	h	m	1000 above MSL			
Degree of protection ⁷⁾			IP65			
Insulation class (according to DIN VDE 0530 Part 1)			F			
Housing varnish			Prime coat black in a/w RAL 9005			
¹⁾ K_m is to be used for calculations with crest values (I_{dN} , I_{max}). For calculations with root-mean-square values (rated data), the torque constant K_m must be multiplied by a factor of $\sqrt{2}$. ²⁾ Values determined according to EN 60034-1. Current and voltage specified as root-mean-square values. ³⁾ Without holding brake. ⁴⁾ Applicable to Bosch Rexroth cables. Rated according to VDE0298-4 (1992) and installation type B2 according to EN 60204-1 (1993) at an ambient temperature of 40 °C. ⁵⁾ Without blower unit. ⁶⁾ If the limits specified are exceeded, the performance data must be reduced if necessary. For reduction factors, refer to the chapter entitled "Environmental Conditions". ⁷⁾ Provided the power and encoder cables are mounted properly.						

Fig. 10-2: Technical data of MHD095A-035

Description	Symbol	Unit	MHD095A-058			
Type of cooling			Natural	Natural	Surface	Liquid
Motor overtemperature			60K	100 K	60 K/100	60 K/100
Electric parameters						
Characteristic motor speed	n_K	min^{-1}	4000			
Continuous torque at standstill	M_{dN}	Nm	12.0	13.5	18.0	
Continuous current at standstill	I_{dN}	A	17.4	19.6	26.1	
Peak current	I_{max}	A	78.3			
Torque constant at 20 °C ¹⁾	K_m	Nm/A	0.76			
Voltage constant at 20 °C	$K_{E(\text{eff})}$	V/1000min ⁻¹	66.1			
Winding resistance at 20 °C	R12	Ω	0.76			
Winding inductivity	L12	mH	4.0			
Number of pole pairs	p		4			
Rated data ²⁾						
Rated speed	n_N	min^{-1}	3000	3000	3000	
Rated torque	M_N	Nm	4.4	8.6	13.5	
Rated current	I_N	A	4.5	8.8	13.8	not
Rated performance	P_N	kW	1.6	3.1	5.1	available
Rated voltage	U_N	V	203	210	220	
Rated frequency	f_N	Hz	200	200	200	
Mechanical parameters						
Moment of inertia of the rotor	J_M	kgm^2	35.2×10^{-4}			
Theoretical maximum torque	M_{max}	Nm	44.0			
Minimum strand cross-section ⁴⁾	S	mm^2	1.5	1.5	2.5	
time constant	T_{th}	min	40	40	20	
Maximum speed	n_{max}	min^{-1}	6000			
Motor mass ^{3) 5)}	m	kg	14.5			
Perm. stor. a. transport temperature	T_L	°C	-20 to +80			
Permissible ambient temperature ⁶⁾	T_{um}	°C	0 to 40			
Maximum setup height ⁶⁾	h	m	1000 above MSL			
Degree of protection ⁷⁾			IP65			
Insulation class (according to DIN VDE 0530 Part 1)			F			
Housing varnish			Prime coat black in a/w RAL 9005			
¹⁾ K_m is to be used for calculations with crest values (I_{dN} , I_{max}). For calculations with root-mean-square values (rated data), the torque constant K_m must be multiplied by a factor of $\sqrt{2}$. ²⁾ Values determined according to EN 60034-1. Current and voltage specified as root-mean-square values. ³⁾ Without holding brake. ⁴⁾ Applicable to Bosch Rexroth cables. Rated according to VDE0298-4 (1992) and installation type B2 according to EN 60204-1 (1993) at an ambient temperature of 40 °C. ⁵⁾ Without blower unit. ⁶⁾ If the limits specified are exceeded, the performance data must be reduced if necessary. For reduction factors, refer to the chapter entitled "Environmental Conditions". ⁷⁾ Provided the power and encoder cables are mounted properly.						

Fig. 10-3: Technical data of MHD095A-058

Description	Symbol	Unit	MHD095B-024			
			Natural 60K	Natural 100 K	Surface 60 K/100	Liquid 60 K/100
Type of cooling						
Motor overtemperature			60K	100 K	60 K/100	60 K/100
Electric parameters						
Characteristic motor speed	n_K	min^{-1}	2000			
Continuous torque at standstill	M_{dN}	Nm	17,0	18,5	25,5	
Continuous current at standstill	I_{dN}	A	11,5	12,5	17,3	
Peak current	I_{max}	A	51,8			
Torque constant at 20 °C ¹⁾	K_m	Nm/A	1,62			
Voltage constant at 20 °C	$K_{E(eff)}$	V/1000min ⁻¹	140,9			
Winding resistance at 20 °C	R12	Ω	1,79			
Winding inductivity	L12	mH	11,9			
Number of pole pairs	p		4			
Rated data ²⁾						
Rated speed	n_N	min^{-1}	3000	3000	3000	
Rated torque	M_N	Nm	6,2	11,5	19,2	
Rated current	I_N	A	3,0	5,5	9,2	
Rated performance	P_N	kW	2,2	4,1	7,0	
Rated voltage	U_N	V	430	440	460	
Rated frequency	f_N	Hz	200	200	200	
Mechanical parameters						
Moment of inertia of the rotor	J_M	kgm ²	49.0 x 10 ⁻⁴			
Theoretical maximum torque	M_{max}	Nm	66,0			
Minimum strand cross-section ⁴⁾	S	mm ²	1,5	1,5	1,5	
time constant	T_{th}	min	40	40	20	
Maximum speed	n_{max}	min^{-1}	4000			
Motor mass ^{3) 5)}	m	kg	19,0			
Perm. stor. a. transport temperature	T_L	°C	-20 to +80			
Permissible ambient temperature ⁶⁾	T_{um}	°C	0 to 40			
Maximum setup height ⁶⁾	h	m	1000 above MSL			
Degree of protection ⁷⁾			IP65			
Insulation class (according to DIN VDE 0530 Part 1)			F			
Housing varnish			Prime coat black in a/w RAL 9005			
¹⁾ K_m is to be used for calculations with crest values (I_{dN} , I_{max}). For calculations with root-mean-square values (rated data), the torque constant K_m must be multiplied by a factor of $\sqrt{2}$. ²⁾ Values determined according to EN 60034-1. Current and voltage specified as root-mean-square values. ³⁾ Without holding brake. ⁴⁾ Applicable to Bosch Rexroth cables. Rated according to VDE0298-4 (1992) and installation type B2 according to EN 60204-1 (1993) at an ambient temperature of 40 °C. ⁵⁾ Without blower unit. ⁶⁾ If the limits specified are exceeded, the performance data must be reduced if necessary. For reduction factors, refer to the chapter entitled "Environmental Conditions". ⁷⁾ Provided the power and encoder cables are mounted properly.						

Fig. 10-4: Technical data of MHD095B-024

Description	Symbol	Unit	MHD095B-035			
Type of cooling			Natural	Natural	Surface	Liquid
Motor overtemperature			60K	100 K	60 K/100	60 K/100
Electric parameters						
Characteristic motor speed	n_K	min^{-1}	3000			
Continuous torque at standstill	M_{dN}	Nm	17.0	18.5	25.5	
Continuous current at standstill	I_{dN}	A	16.1	17.5	24.2	
Peak current	I_{max}	A	72.5			
Torque constant at 20 °C ¹⁾	K_m	Nm/A	1.16			
Voltage constant at 20 °C	$K_{E(\text{eff})}$	V/1000min ⁻¹	101			
Winding resistance at 20 °C	R12	Ω	0.92			
Winding inductivity	L12	mH	5.7			
Number of pole pairs	p		4			
Rated data ²⁾						
Rated speed	n_N	min^{-1}	3000	3000	3000	
Rated torque	M_N	Nm	4.9	7.2	18.6	
Rated current	I_N	A	3.2	4.8	11.6	
Rated performance	P_N	kW	1.7	2.6	6.8	
Rated voltage	U_N	V	307	309	327	
Rated frequency	f_N	Hz	200	200	200	
Mechanical parameters						
Moment of inertia of the rotor	J_M	kgm^2	49.0×10^{-4}			
Theoretical maximum torque	M_{max}	Nm	66.0			
Minimum strand cross-section ⁴⁾	S	mm^2	1.5	1.5	1.5	
time constant	T_{th}	min	40	40	20	
Maximum speed	n_{max}	min^{-1}	4000			
Motor mass ^{3) 5)}	m	kg	19.0			
Perm. stor. a. transport temperature	T_L	°C	-20 to +80			
Permissible ambient temperature ⁶⁾	T_{um}	°C	0 to 40			
Maximum setup height ⁶⁾	h	m	1000 above MSL			
Degree of protection ⁷⁾			IP65			
Insulation class (according to DIN VDE 0530 Part 1)			F			
Housing varnish			Prime coat black in a/w RAL 9005			
¹⁾ K_m is to be used for calculations with crest values (I_{dN} , I_{max}). For calculations with root-mean-square values (rated data), the torque constant K_m must be multiplied by a factor of $\sqrt{2}$. ²⁾ Values determined according to EN 60034-1. Current and voltage specified as root-mean-square values. ³⁾ Without holding brake. ⁴⁾ Applicable to Bosch Rexroth cables. Rated according to VDE0298-4 (1992) and installation type B2 according to EN 60204-1 (1993) at an ambient temperature of 40 °C. ⁵⁾ Without blower unit. ⁶⁾ If the limits specified are exceeded, the performance data must be reduced if necessary. For reduction factors, refer to the chapter entitled "Environmental Conditions". ⁷⁾ Provided the power and encoder cables are mounted properly.						

Fig. 10-5: Technical data of MHD095B-035

Description	Symbol	Unit	MHD095B-058			
Type of cooling			Natural	Natural	Surface	Liquid
Motor overtemperature			60K	100 K	60 K/100	60 K/100
Electric parameters						
Characteristic motor speed	n_K	min^{-1}	4000			
Continuous torque at standstill	M_{dN}	Nm	17.0	18.5	25.5	
Continuous current at standstill	I_{dN}	A	22.8	24.8	34.2	
Peak current	I_{max}	A	102.6			
Torque constant at 20 °C ¹⁾	K_m	Nm/A	0.82			
Voltage constant at 20 °C	$K_{E(eff)}$	V/1000min ⁻¹	71.3			
Winding resistance at 20 °C	R12	Ω	0.46			
Winding inductivity	L12	mH	2.9			
Number of pole pairs	p		4			
Rated data ²⁾						
Rated speed	n_N	min^{-1}	2000	2000	2000	
Rated torque	M_N	Nm	7.0	12.1	16.5	
Rated current	I_N	A	6.5	11.5	18.5	not
Rated performance	P_N	kW	1.6	2.9	4.8	available
Rated voltage	U_N	V	146	150	157	
Rated frequency	f_N	Hz	133	133	133	
Mechanical parameters						
Moment of inertia of the rotor	J_M	kgm^2	49.0×10^{-4}			
Theoretical maximum torque	M_{max}	Nm	66.0			
Minimum strand cross-section ⁴⁾	S	mm^2	1.5	2.5	4.0	
time constant	T_{th}	min	40	40	20	
Maximum speed	n_{max}	min^{-1}	6000			
Motor mass ^{3) 5)}	m	kg	19.0			
Perm. stor. a. transport temperature	T_L	°C	-20 to +80			
Permissible ambient temperature ⁶⁾	T_{um}	°C	0 to 40			
Maximum setup height ⁶⁾	h	m	1000 above MSL			
Degree of protection ⁷⁾			IP65			
Insulation class (according to DIN VDE 0530 Part 1)			F			
Housing varnish			Prime coat black in a/w RAL 9005			
¹⁾ K_m is to be used for calculations with crest values (I_{dN} , I_{max}). For calculations with root-mean-square values (rated data), the torque constant K_m must be multiplied by a factor of $\sqrt{2}$. ²⁾ Values determined according to EN 60034-1. Current and voltage specified as root-mean-square values. ³⁾ Without holding brake. ⁴⁾ Applicable to Bosch Rexroth cables. Rated according to VDE0298-4 (1992) and installation type B2 according to EN 60204-1 (1993) at an ambient temperature of 40 °C. ⁵⁾ Without blower unit. ⁶⁾ If the limits specified are exceeded, the performance data must be reduced if necessary. For reduction factors, refer to the chapter entitled "Environmental Conditions". ⁷⁾ Provided the power and encoder cables are mounted properly.						

Fig. 10-6: Technical data of MHD095B-058

Description	Symbol	Unit	MHD095C-024			
Type of cooling			Natural	Natural	Surface	Liquid
Motor overtemperature			60K	100 K	60 K/100	60 K/100
Electric parameters						
Characteristic motor speed	n_K	min^{-1}	2000			
Continuous torque at standstill	M_{dN}	Nm	21.0	23.0	31.5	
Continuous current at standstill	I_{dN}	A	14.3	15.7	21.5	
Peak current	I_{max}	A	64.4			
Torque constant at 20 °C ¹⁾	K_m	Nm/A	1.62			
Voltage constant at 20 °C	$K_{E(\text{eff})}$	V/1000min ⁻¹	141			
Winding resistance at 20 °C	R12	Ω	1.25			
Winding inductivity	L12	mH	8.6			
Number of pole pairs	p		4			
Rated data ²⁾						
Rated speed	n_N	min^{-1}	2000	2000	2000	
Rated torque	M_N	Nm	11.3	16.3	25.5	
Rated current	I_N	A	5.4	7.9	12.3	not
Rated performance	P_N	kW	2.7	4.0	6.4	available
Rated voltage	U_N	V	292	297	310	
Rated frequency	f_N	Hz	133	133	133	
Mechanical parameters						
Moment of inertia of the rotor	J_M	kgm^2	61.3×10^{-4}			
Theoretical maximum torque	M_{max}	Nm	88.0			
Minimum strand cross-section ⁴⁾	S	mm^2	1.5	1.5	1.5	
time constant	T_{th}	min	40	40	20	
Maximum speed	n_{max}	min^{-1}	4500			
Motor mass ^{3) 5)}	m	kg	22.5			
Perm. stor. a. transport temperature	T_L	°C	-20 to +80			
Permissible ambient temperature ⁶⁾	T_{um}	°C	0 to 40			
Maximum setup height ⁶⁾	h	m	1000 above MSL			
Degree of protection ⁷⁾			IP65			
Insulation class (according to DIN VDE 0530 Part 1)			F			
Housing varnish			Prime coat black in a/w RAL 9005			
¹⁾ K_m is to be used for calculations with crest values (I_{dN} , I_{max}). For calculations with root-mean-square values (rated data), the torque constant K_m must be multiplied by a factor of $\sqrt{2}$. ²⁾ Values determined according to EN 60034-1. Current and voltage specified as root-mean-square values. ³⁾ Without holding brake. ⁴⁾ Applicable to Bosch Rexroth cables. Rated according to VDE0298-4 (1992) and installation type B2 according to EN 60204-1 (1993) at an ambient temperature of 40 °C. ⁵⁾ Without blower unit. ⁶⁾ If the limits specified are exceeded, the performance data must be reduced if necessary. For reduction factors, refer to the chapter entitled "Environmental Conditions". ⁷⁾ Provided the power and encoder cables are mounted properly.						

Fig. 10-7: Technical data of MHD095C-024

Description	Symbol	Unit	MHD095C-035			
			Natural 60K	Natural 100 K	Surface 60 K/100	Liquid 60 K/100
Type of cooling						
Motor overtemperature			60K	100 K	60 K/100	60 K/100
Electric parameters						
Characteristic motor speed	n_K	min^{-1}	3000			
Continuous torque at standstill	M_{dN}	Nm	21.0	23.0	31.5	
Continuous current at standstill	I_{dN}	A	20.1	22.0	30.2	
Peak current	I_{max}	A	90.5			
Torque constant at 20 °C ¹⁾	K_m	Nm/A	1.15			
Voltage constant at 20 °C	$K_{E(\text{eff})}$	V/1000min ⁻¹	100.0			
Winding resistance at 20 °C	R12	Ω	0.67			
Winding inductivity	L12	mH	4.5			
Number of pole pairs	p		4			
Rated data ²⁾						
Rated speed	n_N	min^{-1}	2000	---	2000	
Rated torque	M_N	Nm	9.6	---	24.5	
Rated current	I_N	A	6.5	---	16.6	not
Rated performance	P_N	kW	2.3	---	6.1	available
Rated voltage	U_N	V	206	---	220	
Rated frequency	f_N	Hz	133	---	133	
Mechanical parameters						
Moment of inertia of the rotor	J_M	kgm^2	61.3×10^{-4}			
Theoretical maximum torque	M_{max}	Nm	88.0			
Minimum strand cross-section ⁴⁾	S	mm^2	1.5	2.5	2.5	
time constant	T_{th}	min	40	40	20	
Maximum speed	n_{max}	min^{-1}	4500			
Motor mass ^{3) 5)}	m	kg	22.5			
Perm. stor. a. transport temperature	T_L	°C	-20 to +80			
Permissible ambient temperature ⁶⁾	T_{um}	°C	0 to 40			
Maximum setup height ⁶⁾	h	m	1000 above MSL			
Degree of protection ⁷⁾			IP65			
Insulation class (according to DIN VDE 0530 Part 1)			F			
Housing varnish			Prime coat black in a/w RAL 9005			
¹⁾ K_m is to be used for calculations with crest values (I_{dN} , I_{max}). For calculations with root-mean-square values (rated data), the torque constant K_m must be multiplied by a factor of $\sqrt{2}$. ²⁾ Values determined according to EN 60034-1. Current and voltage specified as root-mean-square values. ³⁾ Without holding brake. ⁴⁾ Applicable to Bosch Rexroth cables. Rated according to VDE0298-4 (1992) and installation type B2 according to EN 60204-1 (1993) at an ambient temperature of 40 °C. ⁵⁾ Without blower unit. ⁶⁾ If the limits specified are exceeded, the performance data must be reduced if necessary. For reduction factors, refer to the chapter entitled "Environmental Conditions". ⁷⁾ Provided the power and encoder cables are mounted properly.						

Fig. 10-8: Technical data of MHD095C-035

Description	Symbol	Unit	MHD095C-058			
Type of cooling			Natural	Natural	Surface	Liquid
Motor overtemperature			60K	100 K	60 K/100	60 K/100
Electric parameters						
Characteristic motor speed	n_K	min^{-1}	4000			
Continuous torque at standstill	M_{dN}	Nm	21.0	23.0	31.5	
Continuous current at standstill	I_{dN}	A	26.0	28.5	39.0	
Peak current	I_{max}	A	117.0			
Torque constant at 20 °C ¹⁾	K_m	Nm/A	0.89			
Voltage constant at 20 °C	$K_{E(\text{eff})}$	V/1000min ⁻¹	77.4			
Winding resistance at 20 °C	R12	Ω	0.4			
Winding inductivity	L12	mH	2.6			
Number of pole pairs	p		4			
Rated data ²⁾						
Rated speed	n_N	min^{-1}	2000	2000	2000	
Rated torque	M_N	Nm	8.4	17.0	23.8	
Rated current	I_N	A	7.4	14.9	20.8	not
Rated performance	P_N	kW	2.0	4.2	5.9	available
Rated voltage	U_N	V	159	164	169	
Rated frequency	f_N	Hz	133	133	133	
Mechanical parameters						
Moment of inertia of the rotor	J_M	kgm^2	61.3×10^{-4}			
Theoretical maximum torque	M_{max}	Nm	88.0			
Minimum strand cross-section ⁴⁾	S	mm^2	2.5	2.5	4.0	
time constant	T_{th}	min	40	40	20	
Maximum speed	n_{max}	min^{-1}	6000			
Motor mass ^{3) 5)}	m	kg	22.5			
Perm. stor. a. transport temperature	T_L	°C	-20 to +80			
Permissible ambient temperature ⁶⁾	T_{um}	°C	0 to 40			
Maximum setup height ⁶⁾	h	m	1000 above MSL			
Degree of protection ⁷⁾			IP65			
Insulation class (according to DIN VDE 0530 Part 1)			F			
Housing varnish			Prime coat black in a/w RAL 9005			
¹⁾ K_m is to be used for calculations with crest values (I_{dN} , I_{max}). For calculations with root-mean-square values (rated data), the torque constant K_m must be multiplied by a factor of $\sqrt{2}$. ²⁾ Values determined according to EN 60034-1. Current and voltage specified as root-mean-square values. ³⁾ Without holding brake. ⁴⁾ Applicable to Bosch Rexroth cables. Rated according to VDE0298-4 (1992) and installation type B2 according to EN 60204-1 (1993) at an ambient temperature of 40 °C. ⁵⁾ Without blower unit. ⁶⁾ If the limits specified are exceeded, the performance data must be reduced if necessary. For reduction factors, refer to the chapter entitled "Environmental Conditions". ⁷⁾ Provided the power and encoder cables are mounted properly.						

Fig. 10-9: Technical data of MHD095C-058

Holding brake

Description	Symbol	Unit	Holding brake data
Motor type			MHD095
Holding torque	M_4	Nm	22
Rated voltage	U_N	V	DC 24 ± 10%
Rated current	I_N	A	0.71
Moment of inertia	J_B	Kgm ²	3.6×10^{-4}
Connection time	t_1	ms	25
Disconnection time	T_2	ms	50
Mass	m_B	kg	1.1

Fig. 10-10: Technical data of MHD095 holding brake (optional)

10.2 Type Code – Ordering Name

Abbrev. Column	1	2	3	4	5	6	7	8	9	0	1	2	3	4	5	6	7	8	9	0	1	2	3	4	5	6	7	8	9	0	
Example:	M	H	D	0	9	5	C	-	0	3	5	-	P	G	1	-	A	N													

- 1. Product**
 - 1.1 MHD..... = MHD

- 2. Motor size**
 - 2.1 095..... = 095

- 3. Motor length**
 - 3.1 Lengths..... = A, B, C

- 4. Windings code**
 - 4.1 MHD095A..... = 024, 035, 058
 - 4.2 MHD095B..... = 024, 035, 058
 - 4.3 MHD095C..... = 024, 035, 058

- 5. Motor encoder**
 - 5.1 digital servo feedback..... = N
 - 5.2 digital servo feedback with integrated multiturn absolute encoder..... = P

- 6. Driven shaft**
 - 6.1 plain shaft (with shaft sealing ring)..... = G
 - 6.2 Shaft with key per DIN 6885-1 (with shaft sealing ring)..... = P

- 7. Holding brake**
 - 7.1 without holding brake..... = 0
 - 7.2 with holding brake 22 Nm..... = 1

- 8. Output direction of power connection ^①**
 - 8.1 Connector to side A..... = A
 - 8.2 Connector to side B..... = B
 - 8.3 Connector to the left..... = L
 - 8.4 Connector to the right..... = R

- 9. Housing design**
 - 9.1 for natural convection or surface cooling..... = N

- 10. Standard reference**

Standard	Title	Edition
DIN 6885-1	Drive Type with Fastenings without Taper Action; Parallel Keys, Keyways, Deep Pattern	1968-08

Note:
 Looking from front onto driven shaft (see picture 1)

t_mhd095_M02en.fh10

Fig. 10-11: MHD095 type code

10.3 Speed-Torque Curves

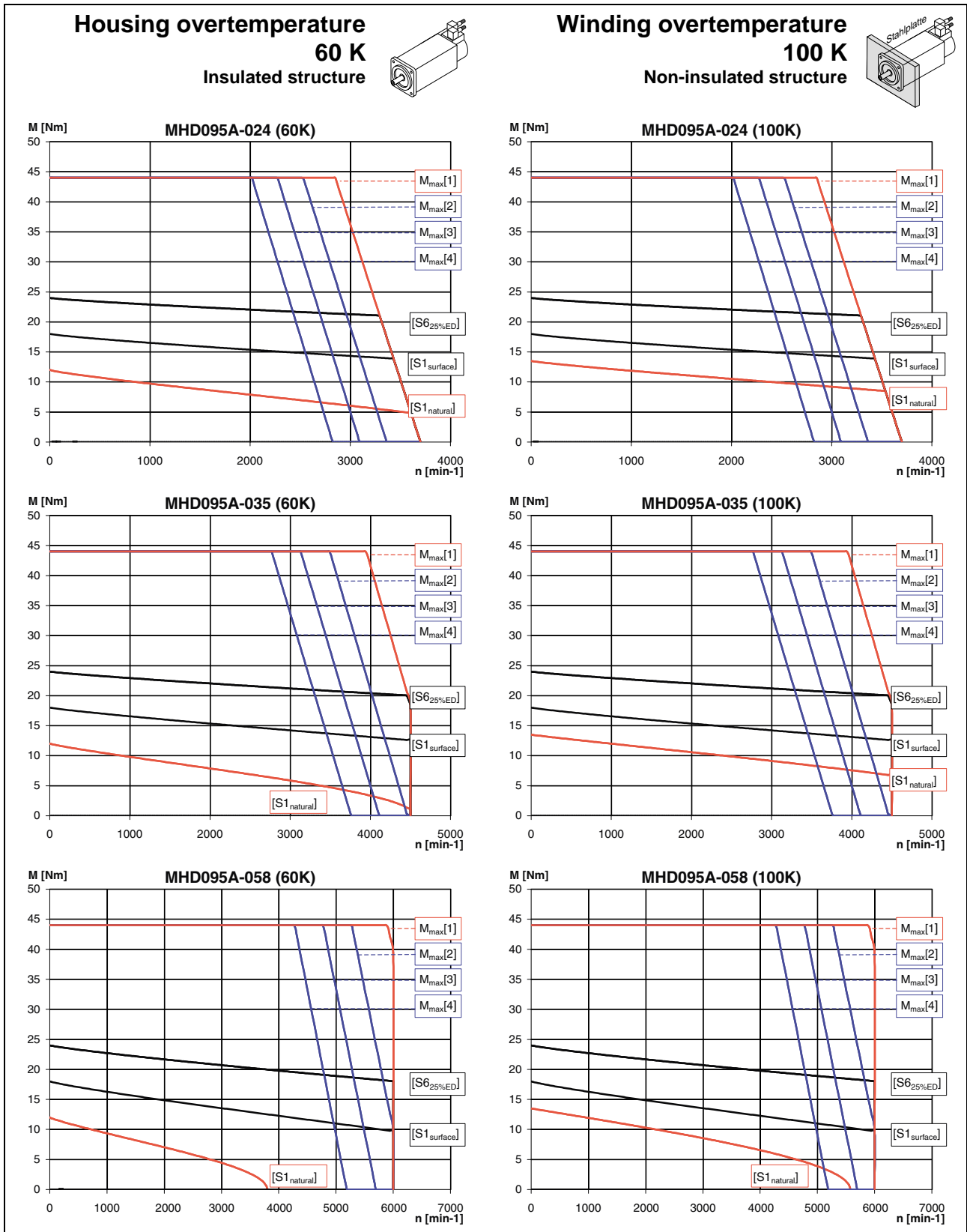

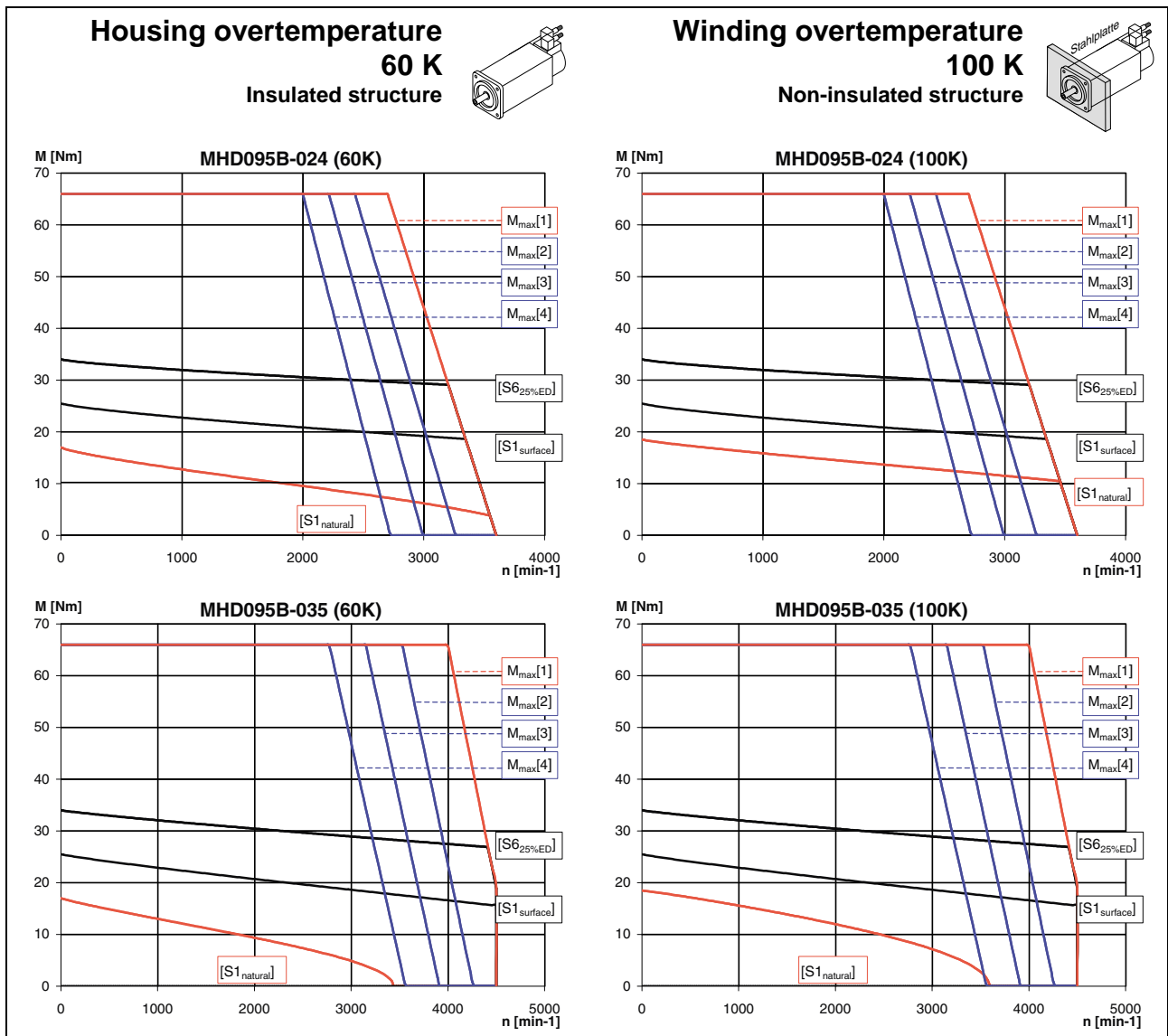

[S1_{natural}]: M_{dN} Natural conv. (S1 continuous operation)
 [S1_{surface}]: M_{dN} Surface cooling (S1 continuous operation)
 [S6]: M_{KB} (S6 intermittent operation)
 M_{max}[1]: HDS to HVR
 M_{max}[2]: HDS to HVE or DKCxx.3 with a power connection of 3 x AC 480 V
 M_{max}[3]: HDS to HVE or DKCxx.3 with a power connection of 3 x AC 440 V
 M_{max}[4]: HDS to HVE or DKCxx.3 with a power connection of 3 x AC 400 V

Fig. 10-12: Characteristic curves

**Housing overtemperature
60 K
Insulated structure**

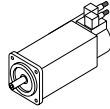

**Winding overtemperature
100 K
Non-insulated structure**

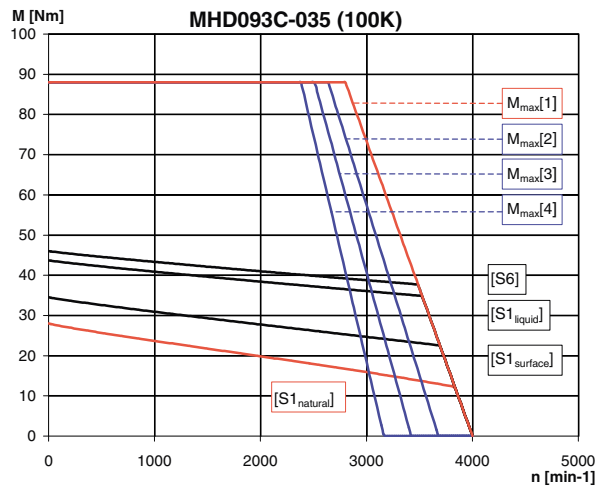
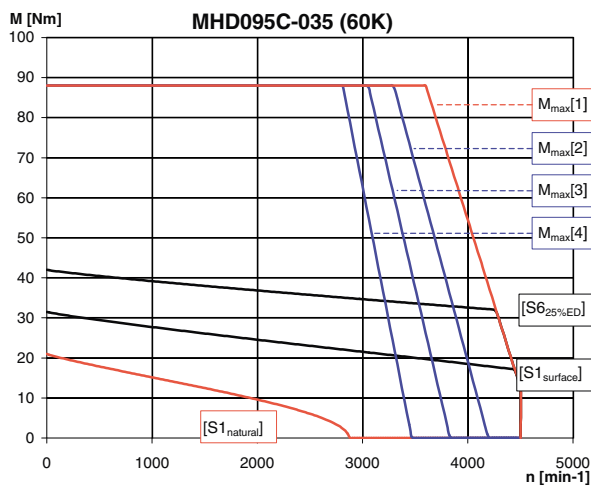
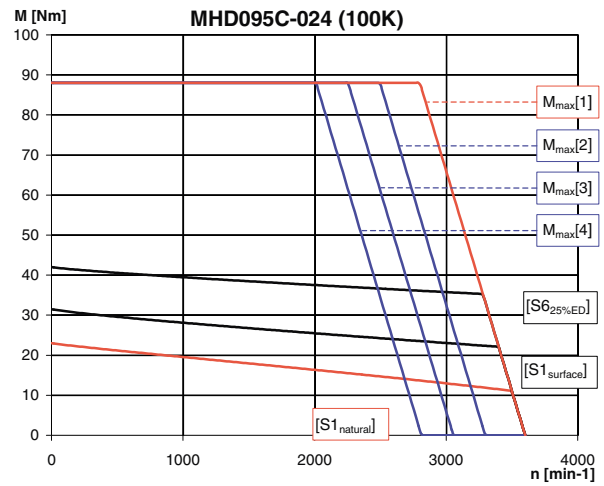
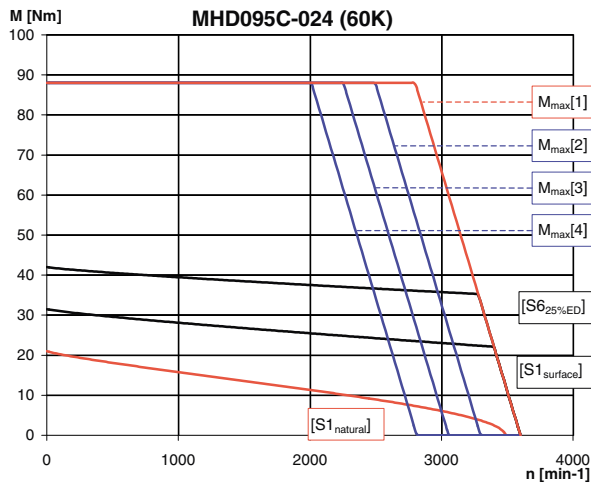
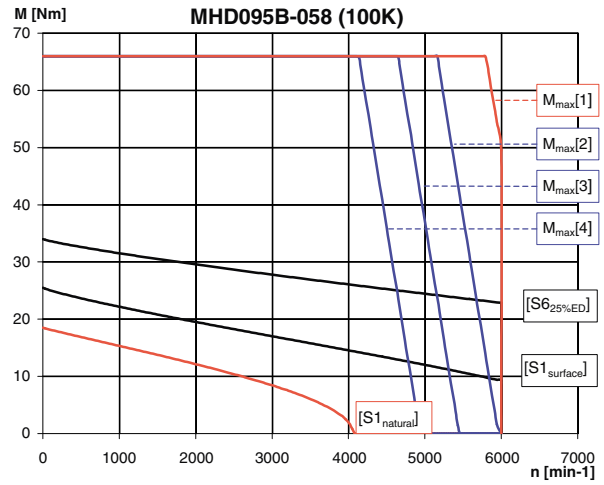
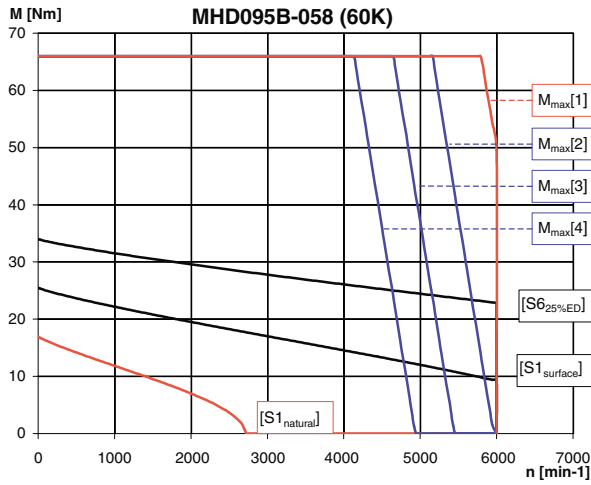
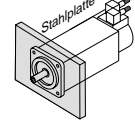

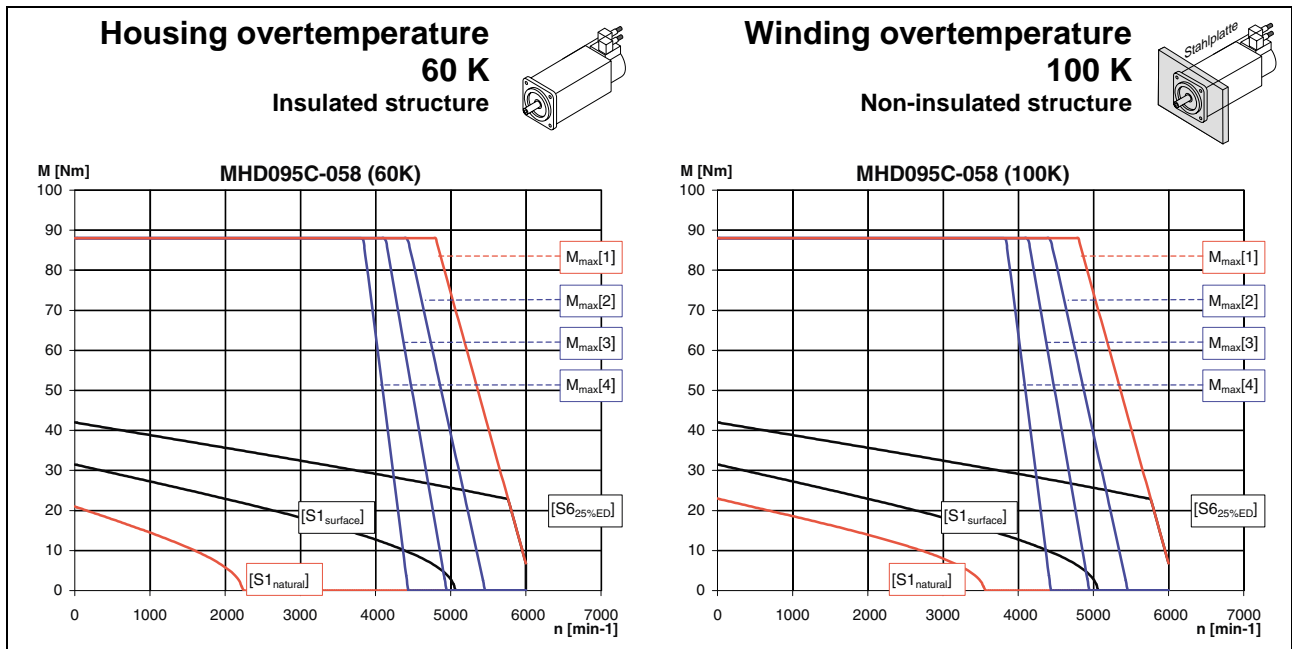

[S1_{natural}]: M_{dN} Natural conv. (S1 continuous operation)
 [S1_{surface}]: M_{dN} Surface cooling (S1 continuous operation)
 [S6]: M_{KB} (S6 intermittent operation)
M_{max}[1]: HDS to HVR
M_{max}[2]: HDS to HVE or DKCxx.3 with a power connection of 3 x AC 480 V
M_{max}[3]: HDS to HVE or DKCxx.3 with a power connection of 3 x AC 440 V
M_{max}[4]: HDS to HVE or DKCxx.3 with a power connection of 3 x AC 400 V

Fig. 10-13: Characteristic curves

10.4 Shaft loads

Permissible maximum radial force $F_{\text{radial_max}}$ and permissible radial force F_{radial}

For explanations refer to Chapter 16.

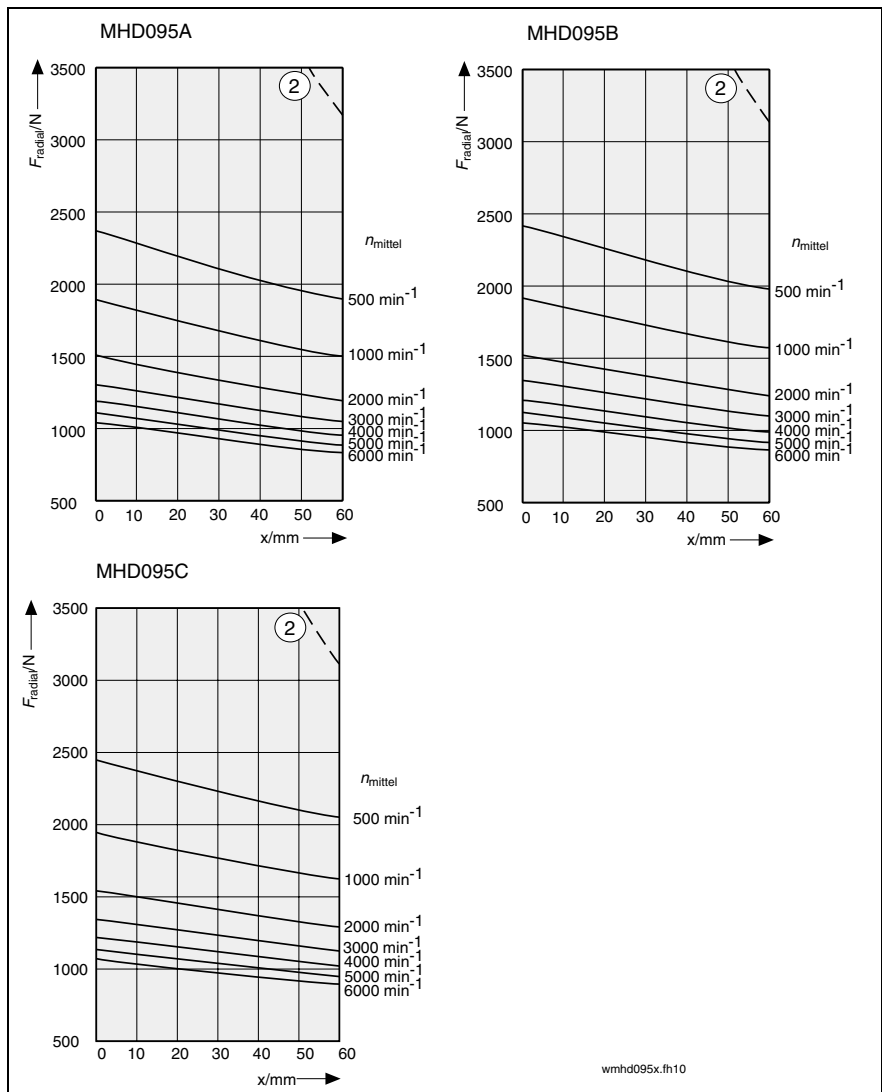

- (1): $F_{\text{radial_max}}$ (plain shaft)
- (2): $F_{\text{radial_max}}$ (shaft with keyway)

Fig. 10-14: MHD095: Permissible maximum radial force $F_{\text{radial_max}}$ and permissible radial force F_{radial}

Permissible axial force F_{axial}

$$F_{\text{axial}} = x \cdot F_{\text{radial}}$$

- x : 0.24 for MHD095A, -B, -C
- F_{axial} : permissible axial force in N
- F_{radial} : permissible radial force in N

Fig. 10-15: MHD095: permissible axial force F_{axial}

10.5 Dimensional Details (Standard Cooling)

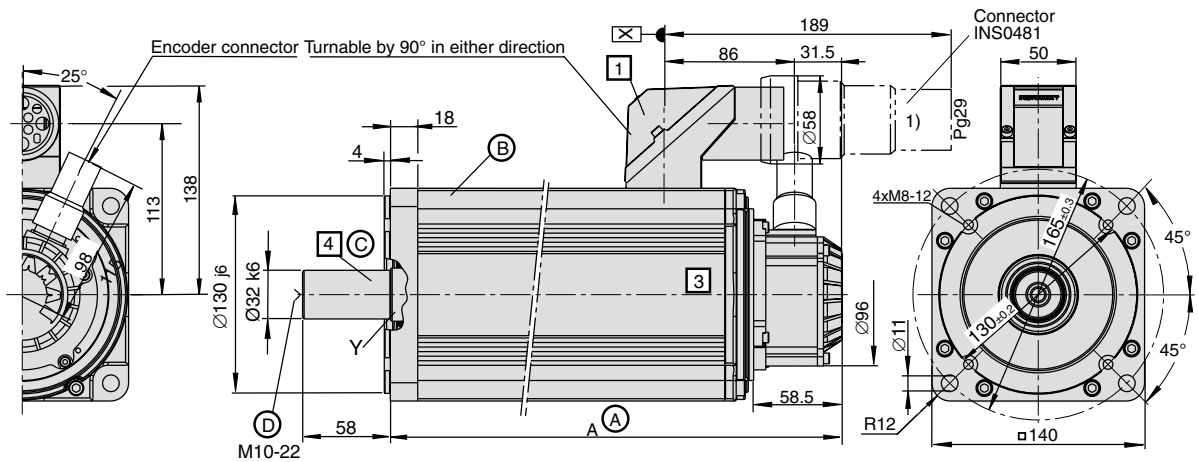

1) Connector not included in the scope of motor delivery

Einzelheit Y:

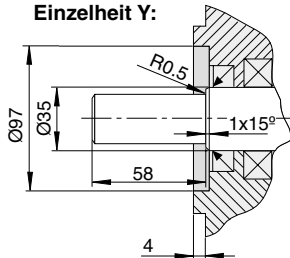

Options:

- 1 Output direction of power connector**
The output direction of the power connector must be selected when ordering. The following output directions are possible:
 - to side A
 - to side B
 - to the right
 - to the left

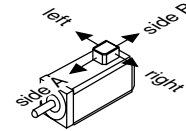

The drawing shows the output direction upon delivery, i.e. to side B. The measures in case of a different output direction are obtained by turning the connector housing theoretically around the X-axis.

A Size table

Frame size	Meas. A
MHD095A	316
MHD095B	356
MHD095C	396

- B** Motor design according to EN 60034-7, 1996-06, B5 for all installation positions
- C**
 - Flange according to DIN 42948, ed. 11.65
 - Positional accuracy with regard to true running, axial running and coaxiality to the shaft according to DIN 42955 Tolerance Class R, ed. 12.81
- D**
 - Shaft end according to DIN 748 Part 3, ed. 07.75, cylindrical
 - Center hole DS M10 according to DIN 332 Part 2, ed. 05.83
 - Max. tightening torque for screw 25.0 Nm
 - Vibration severity grade N according to DIN VDE 0530 Part 14, ed. 02.93

- 2 Motor encoder**
 - Digital servo feedback (HSF)
 - Digital servo feedback (HSF) with integrated multiturn absolute encoder
 Measures are identical.
- 3 Holding brake**
 - Without holding brake
 - With holding brake
 Measures are identical.
- 4 Output shaft**
 - Plain shaft (preferred type)
 - With keyway according to DIN 6885 Sheet 1, ed. 08.68 (Caution! Balanced with entire keyway!)

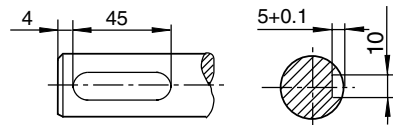

Matching keyway, DIN 6885-A 10 x 8 x 45, Not part of general delivery.

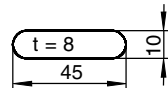

M02MH095_A.fh10

Fig. 10-16: Dimensional details of MHD095.-...-N

10.6 Blower Units

MHD motors can also be delivered with optional blower units. Please refer to the "Surface" column of the data sheets for performance data of surface-cooled motors. The mechanical dimensions of the blower units are represented in the dimension drawings. The possibilities of combining motor and blower unit and the technical data of the blowers are represented in the table below.

Motor	Ordering name of blower unit			
	LEMD-RB090B1XX	LEMD-RB090B2XX	LEMH-AB093B1XX	LEMH-AB093B2XX
MHD095A-xxx-xxx-Nxxxx	---	---	x	x
MHD095B-xxx-xxx-Nxxxx	x	x	x	x
MHD095C-xxx-xxx-Nxxxx	x	x	x	x
--- Blower installation <u>not</u> possible; x Blower installation possible				

Technical data of blower unit			LEMD-RB090B1XX	LEMD-RB090B2XX	LEMH-AB093B1XX	LEMH-AB093B2XX
Description	Symbol	Unit				
Type of cooling			Radial		axial	
Air flow			B ⇒A blowing		B ⇒A blowing	
Rated voltage	U_n	V	230 V, ±15% 50 / 60 Hz	115 V, ±10% 50 / 60 Hz	230 V, ±15% 50 / 60 Hz	115 V, ±10% 50 / 60 Hz
Power consumption	S_n	VA	45 / 43	40 / 39	45 / 43	40 / 39
Rated current	I	A	0.31 / 0.25	0.53 / 0.46	0.31 / 0.25	0.53 / 0.46
Mean air volume	V	m ³ /h	340	390	340	390
Blower unit mass	m_L	kg	1.2	1.1	1.2	1.1
Noise level		dB(A)	48 / 52	48 / 52	48 / 52	48 / 52

Fig. 10-17: Technical data of MHD095 blower units (optional)

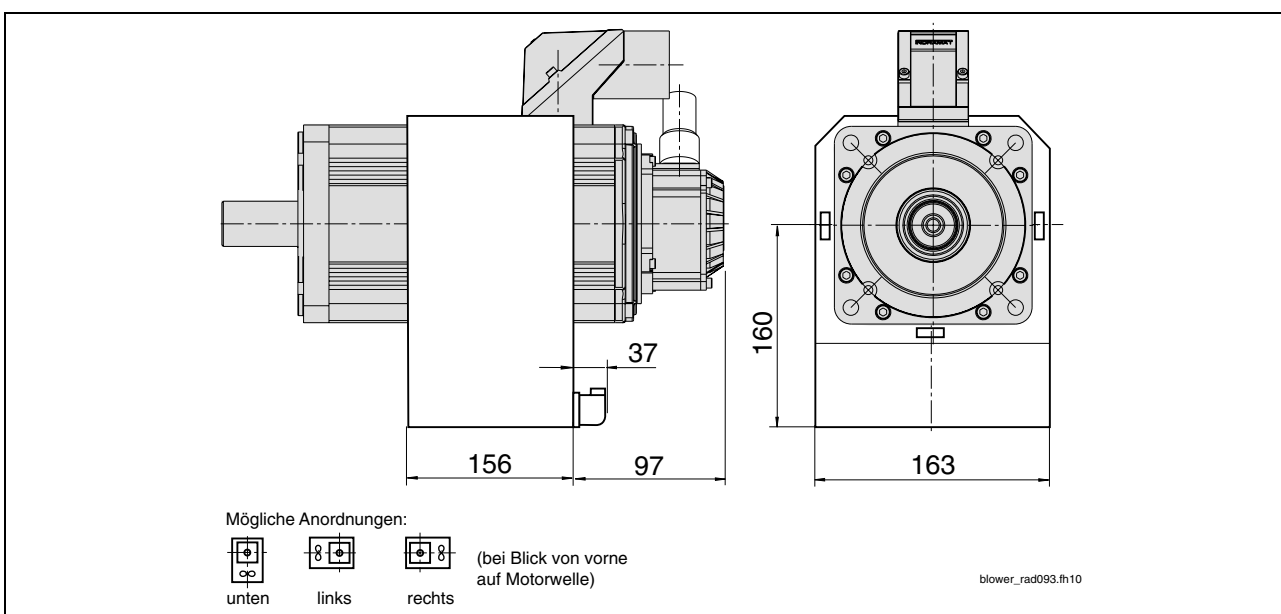

Fig. 10-18: Dimensional details of MHD095 with radial blower

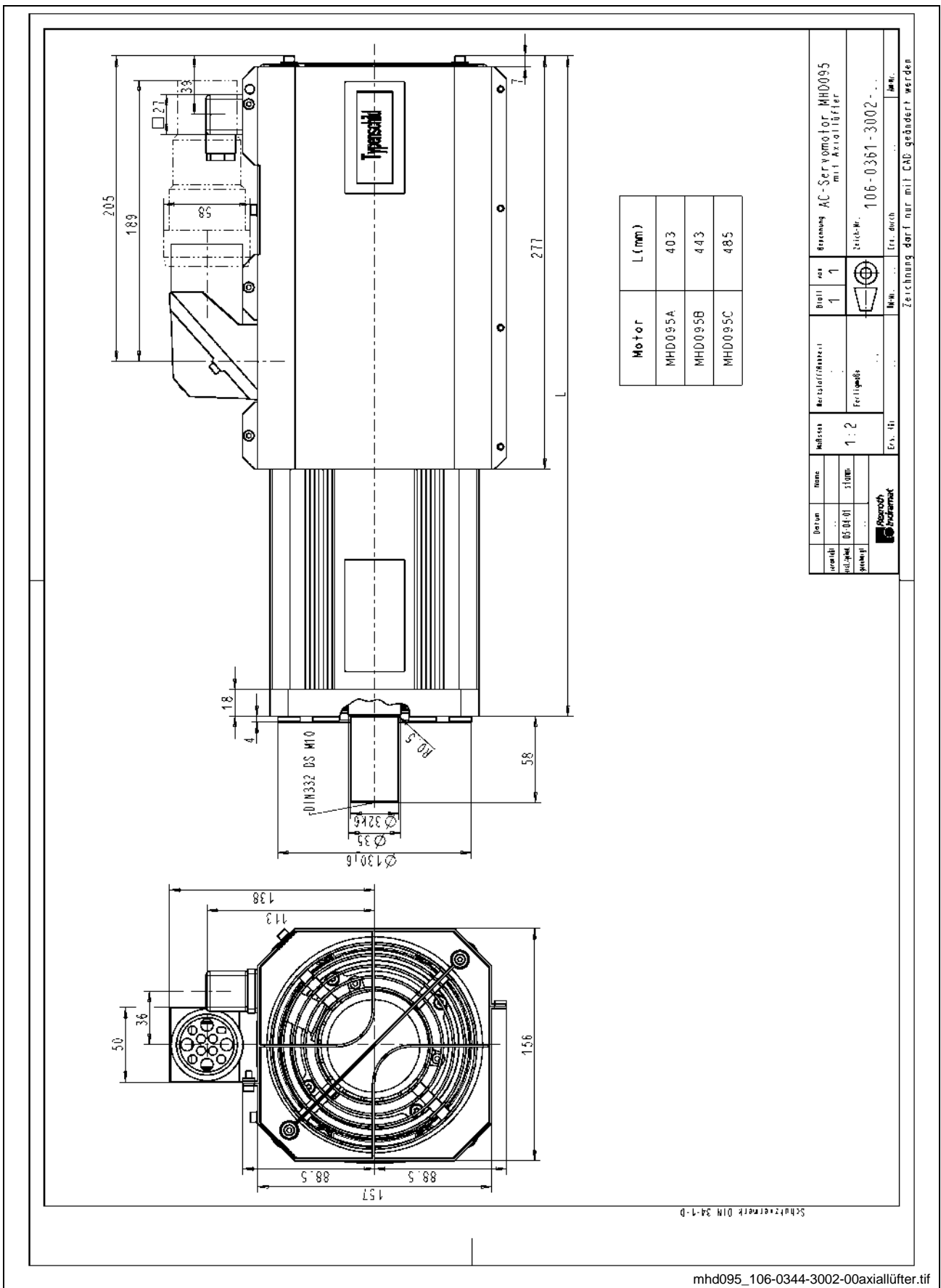

Fig. 10-19: Dimensional details of MHD095 with axial blower

11 MHD112

11.1 Technical data

Description	Symbol	Unit	MHD112A-024			
			Natural 60K	Natural 100 K	Surface 60 K/100	Liquid 60 K/100
Type of cooling			Natural 60K	Natural 100 K	Surface 60 K/100	Liquid 60 K/100
Motor overtemperature						
Electric parameters						
Characteristic motor speed	n_K	min^{-1}	2000			
Continuous torque at standstill	M_{dN}	Nm	15.0	17.0	22.5	not
Continuous current at standstill	I_{dN}	A	13.1	15.9	19.7	available
Peak current	I_{max}	A	59.0			
Torque constant at 20 °C ¹⁾	K_m	Nm/A	1.28			
Voltage constant at 20 °C	$K_{E(\text{eff})}$	V/1000min ⁻¹	116.4			
Winding resistance at 20 °C	R12	Ω	1.45			
Winding inductivity	L12	mH	14.0			
Number of pole pairs	p		4			
Rated data ²⁾						
Rated speed	n_N	min^{-1}	2500	2500	2500	
Rated torque	M_N	Nm	10.1	13.8	19.4	
Rated current	I_N	A	6.2	9.1	12.0	not
Rated performance	P_N	kW	3.2	4.8	6.4	available
Rated voltage	U_N	V	314	332	355	
Rated frequency	f_N	Hz	167	167	167	
Mechanical parameters						
Moment of inertia of the rotor	J_M	kgm^2	110 x 10 ⁻⁴			
Theoretical maximum torque	M_{max}	Nm	54.0			
Minimum strand cross-section ⁴⁾	S	mm^2	1.5	in	1.5	not
time constant	T_{th}	min	40	Vorbereitung	20	lieferbar
Maximum speed	n_{max}	min^{-1}	4000			
Motor mass ^{3) 5)}	m	kg	23.0			
Perm. stor. a. transport temperature	T_L	°C	-20 to +80			
Permissible ambient temperature ⁶⁾	T_{um}	°C	0 to 40			
Maximum setup height ⁶⁾	h	m	1000 above MSL			
Degree of protection ⁷⁾			IP65			
Insulation class (according to DIN VDE 0530 Part 1)			F			
Housing varnish			Prime coat black in a/w RAL 9005			
¹⁾ K_m is to be used for all calculations with crest values (I_{dN} , I_{max}). $K_{mE} = K_m \cdot \sqrt{2}$; K_{mE} is to be used for all calculations with root-mean-square currents (I_N); ²⁾ Values determined according to EN 60034-1. Current and voltage specified as root-mean-square values. ³⁾ Without holding brake. ⁴⁾ Applicable to Bosch Rexroth cables. Rated according to VDE0298-4 (1992) and installation type B2 according to EN 60204-1 (1993) at an ambient temperature of 40 °C. ⁵⁾ Without blower unit. ⁶⁾ If the limits specified are exceeded, the performance data must be reduced if necessary. For reduction factors, refer to the chapter entitled "Environmental Conditions". ⁷⁾ Provided the power and encoder cables are mounted properly.						

Fig. 11-1: Technical data of MHD112A-024

Description	Symbol	Unit	MHD112A-035			
Type of cooling			Natural	Natural	Surface	Liquid
Motor overtemperature			60K	100 K	60 K/100	60 K/100
Electric parameters						
Characteristic motor speed	n_K	min^{-1}	3000			
Continuous torque at standstill	M_{dN}	Nm	15.0	17.0	22.5	not
Continuous current at standstill	I_{dN}	A	14.6	16.6	21.9	available
Peak current	I_{max}	A	65.7			
Torque constant at 20 °C ¹⁾	K_m	Nm/A	1.19			
Voltage constant at 20 °C	$K_{E(\text{eff})}$	V/1000min ⁻¹	103.0			
Winding resistance at 20 °C	R12	Ω	1.1			
Winding inductivity	L12	mH	10.9			
Number of pole pairs	p		4			
Rated data ²⁾						
Rated speed	n_N	min^{-1}	3000	3000	3000	
Rated torque	M_N	Nm	7.8	13.2	18.0	
Rated current	I_N	A	5.4	9.11	12.4	not
Rated performance	P_N	kW	2.9	5.0	6.9	available
Rated voltage	U_N	V	323	343	365	
Rated frequency	f_N	Hz	200	200	200	
Mechanical parameters						
Moment of inertia of the rotor	J_M	kgm^2	110.0×10^{-4}			
Theoretical maximum torque	M_{max}	Nm	54.0			
Minimum strand cross-section ⁴⁾	S	mm^2	1.5	1.5	1.5	not
time constant	T_{th}	min	40	40	20	lieferbar
Maximum speed	n_{max}	min^{-1}	4000			
Motor mass ^{3) 5)}	m	kg	23.0			
Perm. stor. a. transport temperature	T_L	°C	-20 to +80			
Permissible ambient temperature ⁶⁾	T_{um}	°C	0 to 40			
Maximum setup height ⁶⁾	h	m	1000 above MSL			
Degree of protection ⁷⁾			IP65			
Insulation class (according to DIN VDE 0530 Part 1)			F			
Housing varnish			Prime coat black in a/w RAL 9005			
¹⁾ K_m is to be used for calculations with crest values (I_{dN} , I_{max}). For calculations with root-mean-square values (rated data), the torque constant K_m must be multiplied by a factor of $\sqrt{2}$. ²⁾ Values determined according to EN 60034-1. Current and voltage specified as root-mean-square values. ³⁾ Without holding brake. ⁴⁾ Applicable to Bosch Rexroth cables. Rated according to VDE0298-4 (1992) and installation type B2 according to EN 60204-1 (1993) at an ambient temperature of 40 °C. ⁵⁾ Without blower unit. ⁶⁾ If the limits specified are exceeded, the performance data must be reduced if necessary. For reduction factors, refer to the chapter entitled "Environmental Conditions". ⁷⁾ Provided the power and encoder cables are mounted properly.						

Fig. 11-2: Technical data of MHD112A-035

Description	Symbol	Unit	MHD112A-058			
Type of cooling			Natural	Natural	Surface	Liquid
Motor overtemperature			60K	100 K	60 K/100	60 K/100
Electric parameters						
Characteristic motor speed	n_K	min^{-1}	4000			
Continuous torque at standstill	M_{dN}	Nm	15.0	17.0	22.5	not
Continuous current at standstill	I_{dN}	A	17.1	20.1	25.7	available
Peak current	I_{max}	A	77.0			
Torque constant at 20 °C ¹⁾	K_m	Nm/A	0.98			
Voltage constant at 20 °C	$K_{E(\text{eff})}$	V/1000 min^{-1}	89.0			
Winding resistance at 20 °C	R12	Ω	0.86			
Winding inductivity	L12	mH	7.8			
Number of pole pairs	p		4			
Rated data ²⁾						
Rated speed	n_N	min^{-1}	3500	3500	3500	
Rated torque	M_N	Nm	7.3	13.0	17.8	
Rated current	I_N	A	5.9	10.9	14.4	not
Rated performance	P_N	kW	3.2	6.0	8.1	available
Rated voltage	U_N	V	324	344	363	
Rated frequency	f_N	Hz	233	233	233	
Mechanical parameters						
Moment of inertia of the rotor	J_M	kgm^2	110.0×10^{-4}			
Theoretical maximum torque	M_{max}	Nm	54.0			
Minimum strand cross-section ⁴⁾	S	mm^2	1.5	1.5	2.5	not
time constant	T_{th}	min	40	40	20	lieferbar
Maximum speed	n_{max}	min^{-1}	4500			
Motor mass ^{3) 5)}	m	kg	23.0			
Perm. stor. a. transport temperature	T_L	°C	-20 to +80			
Permissible ambient temperature ⁶⁾	T_{um}	°C	0 to 40			
Maximum setup height ⁶⁾	h	m	1000 above MSL			
Degree of protection ⁷⁾			IP65			
Insulation class (according to DIN VDE 0530 Part 1)			F			
Housing varnish			Prime coat black in a/w RAL 9005			
¹⁾ K_m is to be used for calculations with crest values (I_{dN} , I_{max}). For calculations with root-mean-square values (rated data), the torque constant K_m must be multiplied by a factor of $\sqrt{2}$. ²⁾ Values determined according to EN 60034-1. Current and voltage specified as root-mean-square values. ³⁾ Without holding brake. ⁴⁾ Applicable to Bosch Rexroth cables. Rated according to VDE0298-4 (1992) and installation type B2 according to EN 60204-1 (1993) at an ambient temperature of 40 °C. ⁵⁾ Without blower unit. ⁶⁾ If the limits specified are exceeded, the performance data must be reduced if necessary. For reduction factors, refer to the chapter entitled "Environmental Conditions". ⁷⁾ Provided the power and encoder cables are mounted properly.						

Fig. 11-3: Technical data of MHD112A-058

Description	Symbol	Unit	MHD112B-024			
Type of cooling			Natural	Natural	Surface	Liquid
Motor overtemperature			60K	100 K	60 K/100	60 K/100
Electric parameters						
Characteristic motor speed	n_K	min^{-1}	2000			
Continuous torque at standstill	M_{dN}	Nm	28.0	33.0	42.0	not
Continuous current at standstill	I_{dN}	A	21.9	26.8	32.9	available
Peak current	I_{max}	A	98.5			
Torque constant at 20 °C ¹⁾	K_m	Nm/A	1.43			
Voltage constant at 20 °C	$K_{E(\text{eff})}$	V/1000min ⁻¹	130.0			
Winding resistance at 20 °C	R12	Ω	0.58			
Winding inductivity	L12	mH	7.6			
Number of pole pairs	p		4			
Rated data ²⁾						
Rated speed	n_N	min^{-1}	3500	3500	3500	
Rated torque	M_N	Nm	8.8	21.6	31.0	
Rated current	I_N	A	4.9	12.4	17.2	not
Rated performance	P_N	kW	3.9	9.9	13.8	available
Rated voltage	U_N	V	461	483	503	
Rated frequency	f_N	Hz	233	233	233	
Mechanical parameters						
Moment of inertia of the rotor	J_M	kgm^2	192.0×10^{-4}			
Theoretical maximum torque	M_{max}	Nm	102.0			
Minimum strand cross-section ⁴⁾	S	mm^2	1.5	2.5	4.0	not
time constant	T_{th}	min	40	40	20	lieferbar
Maximum speed	n_{max}	min^{-1}	4000			
Motor mass ^{3) 5)}	m	kg	34.0			
Perm. stor. a. transport temperature	T_L	°C	-20 to +80			
Permissible ambient temperature ⁶⁾	T_{um}	°C	0 to 40			
Maximum setup height ⁶⁾	h	m	1000 above MSL			
Degree of protection ⁷⁾			IP65			
Insulation class (according to DIN VDE 0530 Part 1)			F			
Housing varnish			Prime coat black in a/w RAL 9005			
¹⁾ K_m is to be used for calculations with crest values (I_{dN} , I_{max}). For calculations with root-mean-square values (rated data), the torque constant K_m must be multiplied by a factor of $\sqrt{2}$. ²⁾ Values determined according to EN 60034-1. Current and voltage specified as root-mean-square values. ³⁾ Without holding brake. ⁴⁾ Applicable to Bosch Rexroth cables. Rated according to VDE0298-4 (1992) and installation type B2 according to EN 60204-1 (1993) at an ambient temperature of 40 °C. ⁵⁾ Without blower unit. ⁶⁾ If the limits specified are exceeded, the performance data must be reduced if necessary. For reduction factors, refer to the chapter entitled "Environmental Conditions". ⁷⁾ Provided the power and encoder cables are mounted properly.						

Fig. 11-4: Technical data of MHD112B-024

Description	Symbol	Unit	MHD112B-035			
Type of cooling			Natural	Natural	Surface	Liquid
Motor overtemperature			60K	100 K	60 K/100	60 K/100
Electric parameters						
Characteristic motor speed	n_K	min^{-1}	3000			
Continuous torque at standstill	M_{dN}	Nm	28.0	33.0	42.0	not
Continuous current at standstill	I_{dN}	A	26.0	31.7	39.0	available
Peak current	I_{max}	A	117.0			
Torque constant at 20 °C ¹⁾	K_m	Nm/A	1.25			
Voltage constant at 20 °C	$K_{E(\text{eff})}$	V/1000min ⁻¹	108.5			
Winding resistance at 20 °C	R12	Ω	0.43			
Winding inductivity	L12	mH	5.5			
Number of pole pairs	p		4			
Rated data ²⁾						
Rated speed	n_N	min^{-1}	2500	2500	2500	
Rated torque	M_N	Nm	13.5	24.4	33.1	
Rated current	I_N	A	8.9	16.6	21.7	not
Rated performance	P_N	kW	4.2	8.0	10.1	available
Rated voltage	U_N	V	280	294	307	
Rated frequency	f_N	Hz	167	167	167	
Mechanical parameters						
Moment of inertia of the rotor	J_M	kgm^2	192×10^{-4}			
Theoretical maximum torque	M_{max}	Nm	102.0			
Minimum strand cross-section ⁴⁾	S	mm^2	2.5	2.5	4.0	not
time constant	T_{th}	min	40	40	20	lieferbar
Maximum speed	n_{max}	min^{-1}	4000			
Motor mass ^{3) 5)}	m	kg	34.0			
Perm. stor. a. transport temperature	T_L	°C	-20 to +80			
Permissible ambient temperature ⁶⁾	T_{um}	°C	0 to 40			
Maximum setup height ⁶⁾	h	m	1000 above MSL			
Degree of protection ⁷⁾			IP65			
Insulation class (according to DIN VDE 0530 Part 1)			F			
Housing varnish			Prime coat black in a/w RAL 9005			
¹⁾ K_m is to be used for calculations with crest values (I_{dN} , I_{max}). For calculations with root-mean-square values (rated data), the torque constant K_m must be multiplied by a factor of $\sqrt{2}$. ²⁾ Values determined according to EN 60034-1. Current and voltage specified as root-mean-square values. ³⁾ Without holding brake. ⁴⁾ Applicable to Bosch Rexroth cables. Rated according to VDE0298-4 (1992) and installation type B2 according to EN 60204-1 (1993) at an ambient temperature of 40 °C. ⁵⁾ Without blower unit. ⁶⁾ If the limits specified are exceeded, the performance data must be reduced if necessary. For reduction factors, refer to the chapter entitled "Environmental Conditions". ⁷⁾ Provided the power and encoder cables are mounted properly.						

Fig. 11-5: Technical data of MHD112B-035

Description	Symbol	Unit	MHD112B-048			
Type of cooling			Natural	Natural	Surface	Liquid
Motor overtemperature			60K	100 K	60 K/100	60 K/100
Electric parameters						
Characteristic motor speed	n_K	min^{-1}	3500			
Continuous torque at standstill	M_{dN}	Nm	28.0	33.0	42.0	not
Continuous current at standstill	I_{dN}	A	35.6	43.5	53.4	available
Peak current	I_{max}	A	160.0			
Torque constant at 20 °C ¹⁾	K_m	Nm/A	0.88			
Voltage constant at 20 °C	$K_{E(\text{eff})}$	V/1000min ⁻¹	80.0			
Winding resistance at 20 °C	R12	Ω	0.22			
Winding inductivity	L12	mH	3.1			
Number of pole pairs	p		4			
Rated data ²⁾						
Rated speed	n_N	min^{-1}	2800	2800	2800	
Rated torque	M_N	Nm	7.7	18.1	30.6	
Rated current	I_N	A	6.9	16.9	27.5	not
Rated performance	P_N	kW	2.7	6.7	11.0	available
Rated voltage	U_N	V	227	236	251	
Rated frequency	f_N	Hz	187	187	187	
Mechanical parameters						
Moment of inertia of the rotor	J_M	kgm^2	192.0×10^{-4}			
Theoretical maximum torque	M_{max}	Nm	102.0			
Minimum strand cross-section ⁴⁾	S	mm^2	4.0	6.0	6.0	not
time constant	T_{th}	min	40	40	20	lieferbar
Maximum speed	n_{max}	min^{-1}	4500			
Motor mass ^{3) 5)}	m	kg	34.0			
Perm. stor. a. transport temperature	T_L	°C	-20 to +80			
Permissible ambient temperature ⁶⁾	T_{um}	°C	0 to 40			
Maximum setup height ⁶⁾	h	m	1000 above MSL			
Degree of protection ⁷⁾			IP65			
Insulation class (according to DIN VDE 0530 Part 1)			F			
Housing varnish			Prime coat black in a/w RAL 9005			
¹⁾ K_m is to be used for calculations with crest values (I_{dN} , I_{max}). For calculations with root-mean-square values (rated data), the torque constant K_m must be multiplied by a factor of $\sqrt{2}$. ²⁾ Values determined according to EN 60034-1. Current and voltage specified as root-mean-square values. ³⁾ Without holding brake. ⁴⁾ Applicable to Bosch Rexroth cables. Rated according to VDE0298-4 (1992) and installation type B2 according to EN 60204-1 (1993) at an ambient temperature of 40 °C. ⁵⁾ Without blower unit. ⁶⁾ If the limits specified are exceeded, the performance data must be reduced if necessary. For reduction factors, refer to the chapter entitled "Environmental Conditions". ⁷⁾ Provided the power and encoder cables are mounted properly.						

Fig. 11-6: Technical data of MHD112B-048

Description	Symbol	Unit	MHD112B-058			
Type of cooling			Natural	Natural	Surface	Liquid
Motor overtemperature			60K	100 K	60 K/100	60 K/100
Electric parameters						
Characteristic motor speed	n_K	min^{-1}	4000			
Continuous torque at standstill	M_{dN}	Nm	28.0	33.0	42.0	not
Continuous current at standstill	I_{dN}	A	40.7	51.4	61.0	available
Peak current	I_{max}	A	183.0			
Torque constant at 20 °C ¹⁾	K_m	Nm/A	0.77			
Voltage constant at 20 °C	$K_{E(\text{eff})}$	V/1000 min^{-1}	70.0			
Winding resistance at 20 °C	R12	Ω	0.17			
Winding inductivity	L12	mH	2.2			
Number of pole pairs	p		4			
Rated data ²⁾						
Rated speed	n_N	min^{-1}	3000	4000	4000	
Rated torque	M_N	Nm	6.2	11.9	26.0	
Rated current	I_N	A	6.4	13.1	26.7	not
Rated performance	P_N	kW	2.3	6.4	13.2	available
Rated voltage	U_N	V	212	286	301	
Rated frequency	f_N	Hz	200	267	267	
Mechanical parameters						
Moment of inertia of the rotor	J_M	kgm^2	192×10^{-4}			
Theoretical maximum torque	M_{max}	Nm	102.0			
Minimum strand cross-section ⁴⁾	S	mm^2	4.0	6.0	10.0	not
time constant	T_{th}	min	40	40	20	lieferbar
Maximum speed	n_{max}	min^{-1}	4500			
Motor mass ^{3) 5)}	m	kg	34.0			
Perm. stor. a. transport temperature	T_L	°C	-20 to +80			
Permissible ambient temperature ⁶⁾	T_{um}	°C	0 to 40			
Maximum setup height ⁶⁾	h	m	1000 above MSL			
Degree of protection ⁷⁾			IP65			
Insulation class (according to DIN VDE 0530 Part 1)			F			
Housing varnish			Prime coat black in a/w RAL 9005			
¹⁾ K_m is to be used for calculations with crest values (I_{dN} , I_{max}). For calculations with root-mean-square values (rated data), the torque constant K_m must be multiplied by a factor of $\sqrt{2}$. ²⁾ Values determined according to EN 60034-1. Current and voltage specified as root-mean-square values. ³⁾ Without holding brake. ⁴⁾ Applicable to Bosch Rexroth cables. Rated according to VDE0298-4 (1992) and installation type B2 according to EN 60204-1 (1993) at an ambient temperature of 40 °C. ⁵⁾ Without blower unit. ⁶⁾ If the limits specified are exceeded, the performance data must be reduced if necessary. For reduction factors, refer to the chapter entitled "Environmental Conditions". ⁷⁾ Provided the power and encoder cables are mounted properly.						

Fig. 11-7: Technical data of MHD112B-058

Description	Symbol	Unit	MHD112C-024			
Type of cooling			Natural	Natural	Surface	Liquid
Motor overtemperature			60K	100 K	60 K/100	60 K/100
Electric parameters						
Characteristic motor speed	n_K	min^{-1}	2000			
Continuous torque at standstill	M_{dN}	Nm	38.0	43.5	57.0	not
Continuous current at standstill	I_{dN}	A	26.6	32.6	39.9	available
Peak current	I_{max}	A	120.0			
Torque constant at 20 °C ¹⁾	K_m	Nm/A	1.6			
Voltage constant at 20 °C	$K_{E(\text{eff})}$	V/1000 min^{-1}	145.5			
Winding resistance at 20 °C	R12	Ω	0.44			
Winding inductivity	L12	mH	6.7			
Number of pole pairs	p		4			
Rated data ²⁾						
Rated speed	n_N	min^{-1}	2500	2500	2500	
Rated torque	M_N	Nm	16.6	32.6	44.1	
Rated current	I_N	A	8.2	17.3	21.8	not
Rated performance	P_N	kW	5.2	11.1	14.1	available
Rated voltage	U_N	V	372	391	404	
Rated frequency	f_N	Hz	167	167	167	
Mechanical parameters						
Moment of inertia of the rotor	J_M	kgm^2	273×10^{-4}			
Theoretical maximum torque	M_{max}	Nm	148.0			
Minimum strand cross-section ⁴⁾	S	mm^2	2.5	4.0	4.0	not
time constant	T_{th}	min	90	90	40	lieferbar
Maximum speed	n_{max}	min^{-1}	4000			
Motor mass ^{3) 5)}	m	kg	45.0			
Perm. stor. a. transport temperature	T_L	°C	-20 to +80			
Permissible ambient temperature ⁶⁾	T_{um}	°C	0 to 40			
Maximum setup height ⁶⁾	h	m	1000 above MSL			
Degree of protection ⁷⁾			IP65			
Insulation class (according to DIN VDE 0530 Part 1)			F			
Housing varnish			Prime coat black in a/w RAL 9005			
¹⁾ K_m is to be used for calculations with crest values (I_{dN} , I_{max}). For calculations with root-mean-square values (rated data), the torque constant K_m must be multiplied by a factor of $\sqrt{2}$. ²⁾ Values determined according to EN 60034-1. Current and voltage specified as root-mean-square values. ³⁾ Without holding brake. ⁴⁾ Applicable to Bosch Rexroth cables. Rated according to VDE0298-4 (1992) and installation type B2 according to EN 60204-1 (1993) at an ambient temperature of 40 °C. ⁵⁾ Without blower unit. ⁶⁾ If the limits specified are exceeded, the performance data must be reduced if necessary. For reduction factors, refer to the chapter entitled "Environmental Conditions". ⁷⁾ Provided the power and encoder cables are mounted properly.						

Fig. 11-8: Technical data of MHD112C-024

Description	Symbol	Unit	MHD112C-035			
Type of cooling			Natural	Natural	Surface	Liquid
Motor overtemperature			60K	100 K	60 K/100	60 K/100
Electric parameters						
Characteristic motor speed	n_K	min^{-1}	3000			
Continuous torque at standstill	M_{dN}	Nm	38.0	43.5	57.0	not
Continuous current at standstill	I_{dN}	A	31.0	38.1	46.5	available
Peak current	I_{max}	A	139.5			
Torque constant at 20 °C ¹⁾	K_m	Nm/A	1.37			
Voltage constant at 20 °C	$K_{E(\text{eff})}$	V/1000min ⁻¹	119.1			
Winding resistance at 20 °C	R12	Ω	0.3			
Winding inductivity	L12	mH	4.2			
Number of pole pairs	p		4			
Rated data ²⁾						
Rated speed	n_N	min^{-1}	2500	2500	2500	
Rated torque	M_N	Nm	15.8	27.6	43.7	
Rated current	I_N	A	9.1	17.1	25.2	not
Rated performance	P_N	kW	4.7	9.0	13.3	available
Rated voltage	U_N	V	303	312	325	
Rated frequency	f_N	Hz	167	167	167	
Mechanical parameters						
Moment of inertia of the rotor	J_M	kgm^2	273×10^{-4}			
Theoretical maximum torque	M_{max}	Nm	148.0			
Minimum strand cross-section ⁴⁾	S	mm^2	2.5	4.0	6.0	not
time constant	T_{th}	min	90	90	40	lieferbar
Maximum speed	n_{max}	min^{-1}	4000			
Motor mass ^{3) 5)}	m	kg	45.0			
Perm. stor. a. transport temperature	T_L	°C	-20 to +80			
Permissible ambient temperature ⁶⁾	T_{um}	°C	0 to 40			
Maximum setup height ⁶⁾	h	m	1000 above MSL			
Degree of protection ⁷⁾			IP65			
Insulation class (according to DIN VDE 0530 Part 1)			F			
Housing varnish			Prime coat black in a/w RAL 9005			
¹⁾ K_m is to be used for calculations with crest values (I_{dN} , I_{max}). For calculations with root-mean-square values (rated data), the torque constant K_m must be multiplied by a factor of $\sqrt{2}$. ²⁾ Values determined according to EN 60034-1. Current and voltage specified as root-mean-square values. ³⁾ Without holding brake. ⁴⁾ Applicable to Bosch Rexroth cables. Rated according to VDE0298-4 (1992) and installation type B2 according to EN 60204-1 (1993) at an ambient temperature of 40 °C. ⁵⁾ Without blower unit. ⁶⁾ If the limits specified are exceeded, the performance data must be reduced if necessary. For reduction factors, refer to the chapter entitled "Environmental Conditions". ⁷⁾ Provided the power and encoder cables are mounted properly.						

Fig. 11-9: Technical data of MHD112C-035

Description	Symbol	Unit	MHD112C-058			
			Natural 60K	Natural 100 K	Surface 60 K/100	Liquid 60 K/100
Type of cooling						
Motor overtemperature			60K	100 K	60 K/100	60 K/100
Electric parameters						
Characteristic motor speed	n_K	min^{-1}	4000			
Continuous torque at standstill	M_{dN}	Nm	38.0	43.5	57.0	not
Continuous current at standstill	I_{dN}	A	53.2	65.3	79.8	available
Peak current	I_{max}	A	239.0			
Torque constant at 20 °C ¹⁾	K_m	Nm/A	0.8			
Voltage constant at 20 °C	$K_{E(\text{eff})}$	V/1000 min^{-1}	72.7			
Winding resistance at 20 °C	R12	Ω	0.12			
Winding inductivity	L12	mH	1.5			
Number of pole pairs	p		4			
Rated data ²⁾						
Rated speed	n_N	min^{-1}	2000	3500	3500	
Rated torque	M_N	Nm	15.3	16.9	43.5	
Rated current	I_N	A	15.2	17.9	43.0	not
Rated performance	P_N	kW	3.9	8.0	19.4	available
Rated voltage	U_N	V	148	260	276	
Rated frequency	f_N	Hz	133	233	233	
Mechanical parameters						
Moment of inertia of the rotor	J_M	kgm^2	273×10^{-4}			
Theoretical maximum torque	M_{max}	Nm	148.0			
Minimum strand cross-section ⁴⁾	S	mm^2	6.0	10.0	16.0	not
time constant	T_{th}	min	90	90	40	lieferbar
Maximum speed	n_{max}	min^{-1}	4500			
Motor mass ^{3) 5)}	m	kg	45.0			
Perm. stor. a. transport temperature	T_L	°C	-20 to +80			
Permissible ambient temperature ⁶⁾	T_{um}	°C	0 to 40			
Maximum setup height ⁶⁾	h	m	1000 above MSL			
Degree of protection ⁷⁾			IP65			
Insulation class (according to DIN VDE 0530 Part 1)			F			
Housing varnish			Prime coat black in a/w RAL 9005			
¹⁾ K_m is to be used for calculations with crest values (I_{dN} , I_{max}). For calculations with root-mean-square values (rated data), the torque constant K_m must be multiplied by a factor of $\sqrt{2}$. ²⁾ Values determined according to EN 60034-1. Current and voltage specified as root-mean-square values. ³⁾ Without holding brake. ⁴⁾ Applicable to Bosch Rexroth cables. Rated according to VDE0298-4 (1992) and installation type B2 according to EN 60204-1 (1993) at an ambient temperature of 40 °C. ⁵⁾ Without blower unit. ⁶⁾ If the limits specified are exceeded, the performance data must be reduced if necessary. For reduction factors, refer to the chapter entitled "Environmental Conditions". ⁷⁾ Provided the power and encoder cables are mounted properly.						

Fig. 11-10: Technical data of MHD112C-058

Description	Symbol	Unit	MHD112D-012 (preliminary data)			
Type of cooling			Natural	Natural	Surface	Liquid
Motor overtemperature			60K	100 K	60 K/100	60 K/100
Electric parameters						
Characteristic motor speed	n_K	min^{-1}	1000			
Continuous torque at standstill	M_{dN}	Nm	48.0		72.0	not
Continuous current at standstill	I_{dN}	A	18.4		27.6	available
Peak current	I_{max}	A	82.8			
Torque constant at 20 °C ¹⁾	K_m	Nm/A	3.03			
Voltage constant at 20 °C	$K_{E(\text{eff})}$	V/1000min ⁻¹	26			
Winding resistance at 20 °C	R12	Ω	0.99			
Winding inductivity	L12	mH	15.0			
Number of pole pairs	p		4			
Rated data ²⁾						
Rated speed	n_N	min^{-1}				
Rated torque	M_N	Nm				
Rated current	I_N	A	in	in	in	not
Rated performance	P_N	kW	Preparation	Preparation	Preparation	available
Rated voltage	U_N	V				
Rated frequency	f_N	Hz				
Mechanical parameters						
Moment of inertia of the rotor	J_M	kgm^2	350×10^{-4}			
Theoretical maximum torque	M_{max}	Nm	187.0			
Minimum strand cross-section ⁴⁾	S	mm^2	1.5		2.5	not
time constant	T_{th}	min	90		40	available
Maximum speed	n_{max}	min^{-1}	2000			
Motor mass ³⁾ ⁵⁾	m	kg	45.0			
Perm. stor. a. transport temperature	T_L	°C	-20 to +80			
Permissible ambient temperature ⁶⁾	T_{um}	°C	0 to 40			
Maximum setup height ⁶⁾	h	m	1000 above MSL			
Degree of protection ⁷⁾			IP65			
Insulation class (according to DIN VDE 0530 Part 1)			F			
Housing varnish			Prime coat black in a/w RAL 9005			
¹⁾ K_m is to be used for calculations with crest values (I_{dN} , I_{max}). For calculations with root-mean-square values (rated data), the torque constant K_m must be multiplied by a factor of $\sqrt{2}$. ²⁾ Values determined according to EN 60034-1. Current and voltage specified as root-mean-square values. ³⁾ Without holding brake. ⁴⁾ Applicable to Bosch Rexroth cables. Rated according to VDE0298-4 (1992) and installation type B2 according to EN 60204-1 (1993) at an ambient temperature of 40 °C. ⁵⁾ Without blower unit. ⁶⁾ If the limits specified are exceeded, the performance data must be reduced if necessary. For reduction factors, refer to the chapter entitled "Environmental Conditions". ⁷⁾ Provided the power and encoder cables are mounted properly.						

Fig. 11-11: Technical data of MHD112D-012

Description	Symbol	Unit	MHD112D-027			
			Natural 60K	Natural 100 K	Surface 60 K/100	Liquid 60 K/100
Type of cooling						
Motor overtemperature			60K	100 K	60 K/100	60 K/100
Electric parameters						
Characteristic motor speed	n_K	min^{-1}	3000			
Continuous torque at standstill	M_{dN}	Nm	48.0	57.0	72.0	not
Continuous current at standstill	I_{dN}	A	31.6	40.2	47.4	available
Peak current	I_{max}	A	142.2			
Torque constant at 20 °C ¹⁾	K_m	Nm/A	1.7			
Voltage constant at 20 °C	$K_{E(\text{eff})}$	V/1000min ⁻¹	154.5			
Winding resistance at 20 °C	R12	Ω	0.35			
Winding inductivity	L12	mH	5.65			
Number of pole pairs	p		4			
Rated data ²⁾						
Rated speed	n_N	min^{-1}	2000	2000	2000	
Rated torque	M_N	Nm	27.3	41.5	59.2	
Rated current	I_N	A	12.7	20.7	27.6	not
Rated performance	P_N	kW	6.9	11.3	15.2	available
Rated voltage	U_N	V	319	331	344	
Rated frequency	f_N	Hz	133	133	133	
Mechanical parameters						
Moment of inertia of the rotor	J_M	kgm^2	350×10^{-4}			
Theoretical maximum torque	M_{max}	Nm	187.0			
Minimum strand cross-section ⁴⁾	S	mm^2	2.5	4.0	6.0	not
time constant	T_{th}	min	90	90	40	available
Maximum speed	n_{max}	min^{-1}	3000			
Motor mass ^{3) 5)}	m	kg	56.0			
Perm. stor. a. transport temperature	T_L	°C	-20 to +80			
Permissible ambient temperature ⁶⁾	T_{um}	°C	0 to 40			
Maximum setup height ⁶⁾	h	m	1000 above MSL			
Degree of protection ⁷⁾			IP65			
Insulation class (according to DIN VDE 0530 Part 1)			F			
Housing varnish			Prime coat black in a/w RAL 9005			
¹⁾ K_m is to be used for calculations with crest values (I_{dN} , I_{max}). For calculations with root-mean-square values (rated data), the torque constant K_m must be multiplied by a factor of $\sqrt{2}$. ²⁾ Values determined according to EN 60034-1. Current and voltage specified as root-mean-square values. ³⁾ Without holding brake. ⁴⁾ Applicable to Bosch Rexroth cables. Rated according to VDE0298-4 (1992) and installation type B2 according to EN 60204-1 (1993) at an ambient temperature of 40 °C. ⁵⁾ Without blower unit. ⁶⁾ If the limits specified are exceeded, the performance data must be reduced if necessary. For reduction factors, refer to the chapter entitled "Environmental Conditions". ⁷⁾ Provided the power and encoder cables are mounted properly.						

Fig. 11-12: Technical data of MHD112D-027

Holding brake

Description	Symbol	Unit	Holding brake 1	Holding brake 2	Holding brake 3
Motor type			MHD112A MHD112B		MHD112C MHD112D
Holding torque	M_4	Nm	22.0	32.0	70.0
Rated voltage	U_N	V	DC 24 ± 10%	DC 24 ± 10%	DC 24 ± 10%
Rated current	I_N	A	0.71	0.93	1.29
Moment of inertia	J_B	kgm ²	3.6×10^{-4}	12.4×10^{-4}	30×10^{-4}
Connection time	t_1	ms	25	15	53
Disconnection time	t_2	ms	50	115	97
Mass	m_B	kg	1.1	2.4	3.8

Fig. 11-13: Technical data of MHD112 holding brake (optional)

11.2 Type Code – Ordering Name

Abbrev. Column	1	2	3	4	5	6	7	8	9	0	1	2	3	4	5	6	7	8	9	0	1	2	3	4	5	6	7	8	9	0						
Example:	M	H	D	1	1	2	C	-	0	2	4	-	N	G	0	-	A	N																		
1. Product																																				
1.1	MHD..... = MHD																																			
2. Motor size																																				
2.1	112..... = 112																																			
3. Motor length																																				
3.1	Lengths..... = A, B, C, D																																			
4. Windings code																																				
4.1	MHD112A..... = 024, 035, 058																																			
4.2	MHD112B..... = 024, 035, 048, 058																																			
4.3	MHD112C..... = 024, 035, 058																																			
4.4	MHD112D..... = 027																																			
5. Motor encoder																																				
5.1	digital servo feedback..... = N																																			
5.2	digital servo feedback with integrated multiturn absolute encoder..... = P																																			
6. Driven shaft																																				
6.1	plain shaft (with shaft sealing ring)..... = G																																			
6.2	Shaft with key per DIN 6885-1 (with shaft sealing ring)..... = P																																			
7. Holding brake ①																																				
7.1	without holding brake..... = 0																																			
7.2	holding brake 22 Nm..... = 1																																			
7.3	holding brake 32 Nm..... = 2																																			
7.4	holding brake 70 Nm..... = 3																																			
8. Output direction of power connection ②																																				
8.1	Connector to side A..... = A																																			
8.2	Connector to side B..... = B																																			
8.3	Connector to the left..... = L																																			
8.4	Connector to the right..... = R																																			
9. Housing design																																				
9.1	for natural convection or surface cooling..... = N																																			
9.2	for natural convection or surface cooling with protection mode IP68..... = P③																																			
10. Standard reference																																				
	Standard	Title																										Edition								
	DIN 6885-1	Drive Type with Fastenings without Taper Action; Parallel Keys, Keyways, Deep Pattern																										1968-08								
	DIN EN 60529	Degrees of protection provided by enclosures (IP code) (IEC 60529:1989 + A1:1999); German version EN 60529:1991 + A1:2000																										2000-09								

Fig. 11-14: Type code MHD112 (page 1)

Note:

- ① Holding brake "1" and "2" is only available with motor length "A" and "B"
Holding brake "3" is only available with motor length "C" and "D"
- ② Looking from front onto driven shaft (see picture 1)
- ③ Housing design "P" is only available with motor length "B" and "C"
See project manual for definition of protection mode IP68

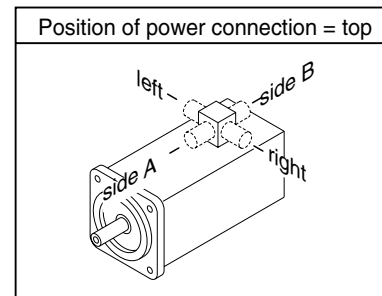
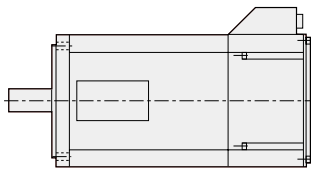
Illustration example: MHD112**Picture 1**

t_mhd112_M15de2.fh10

Fig. 11-15: MDH112 type code (page 2)

11.3 Speed-Torque Curves

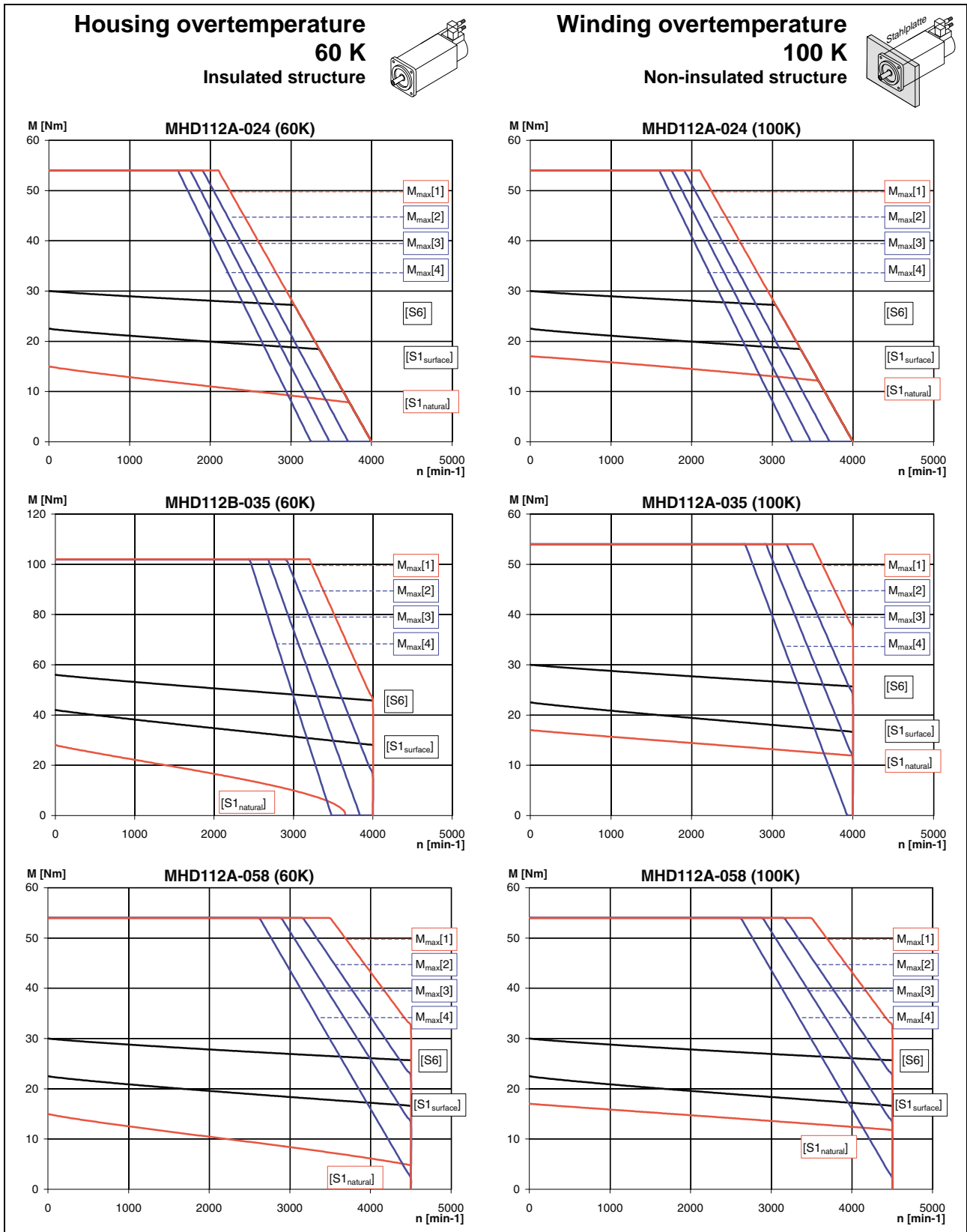

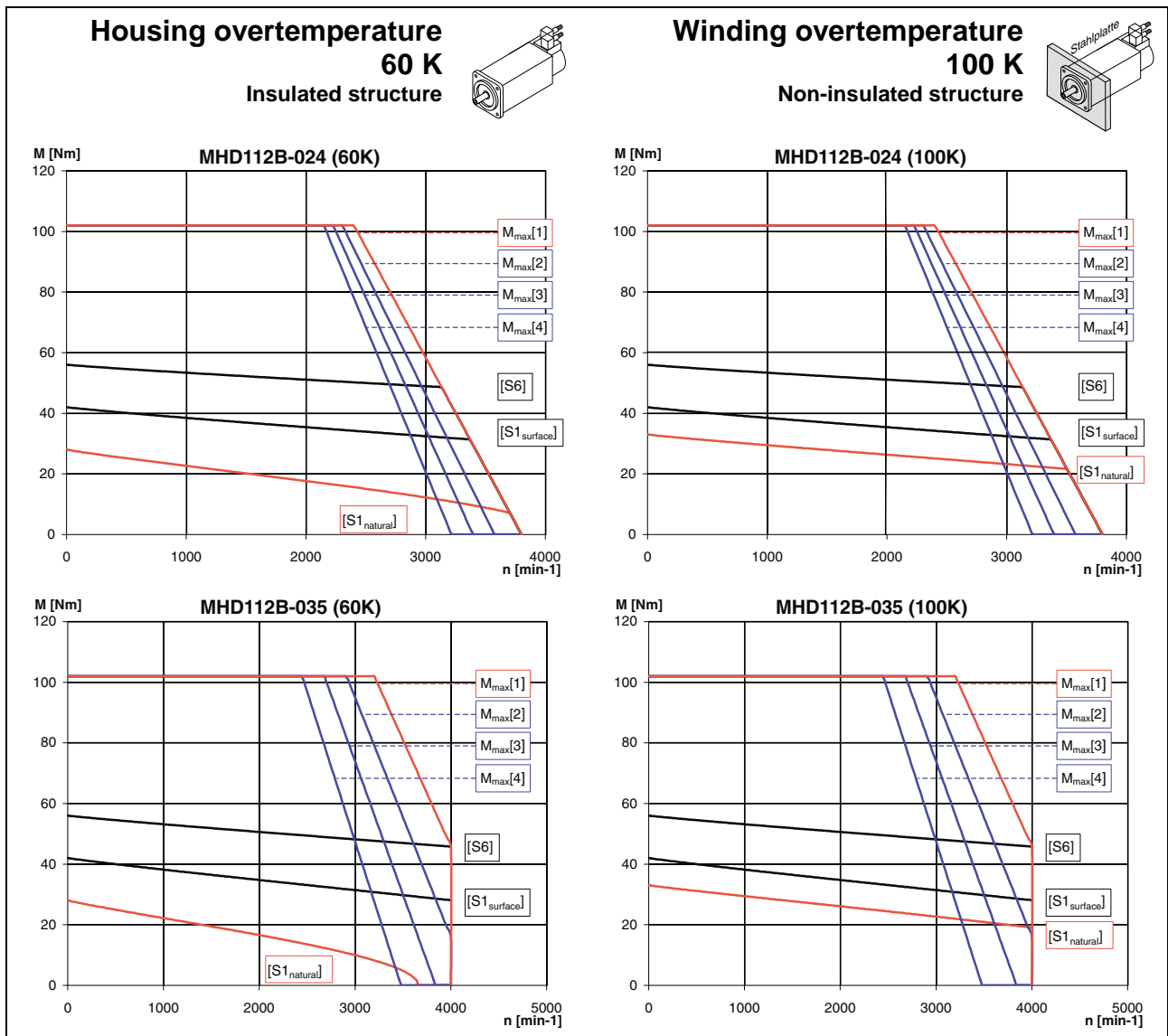

[S1_{natural}]: M_{dN} Natural conv. (S1 continuous operation)
 [S1_{surface}]: M_{dN} Surface cooling (S1 continuous operation)
 [S6]: M_{KB} (S6 intermittent operation)
 $M_{max}[1]$: HDS to HVR
 $M_{max}[2]$: HDS to HVE or DKCxx.3 with a power connection of 3 x AC 480 V
 $M_{max}[3]$: HDS to HVE or DKCxx.3 with a power connection of 3 x AC 440 V
 $M_{max}[4]$: HDS to HVE or DKCxx.3 with a power connection of 3 x AC 400 V

Fig. 11-16: Characteristic curves

**Housing overtemperature
60 K
Insulated structure**

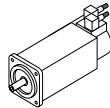

**Winding overtemperature
100 K
Non-insulated structure**

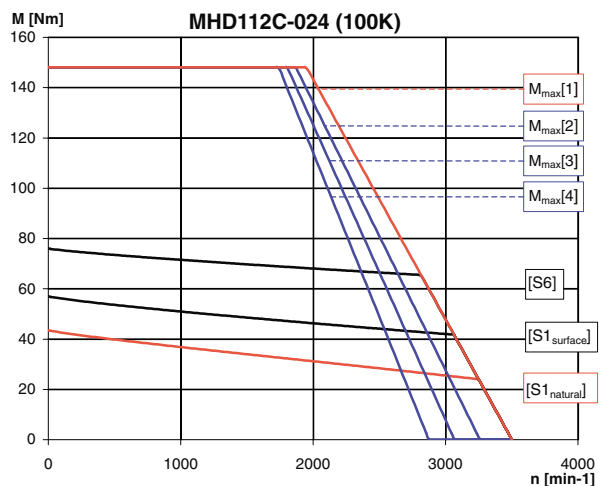
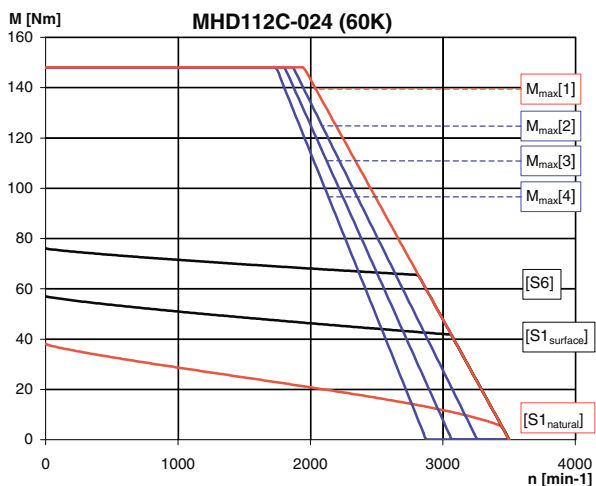
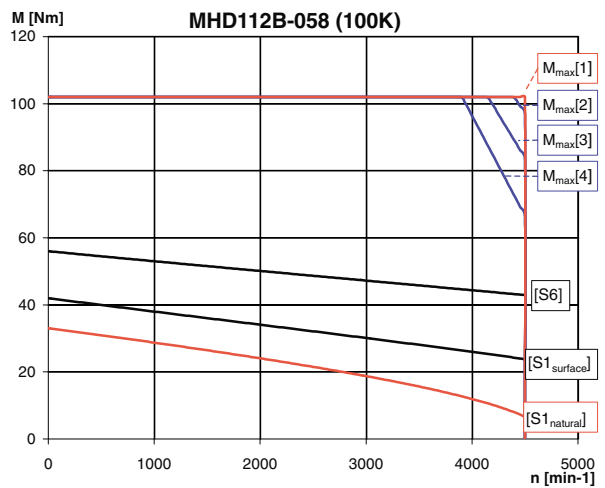
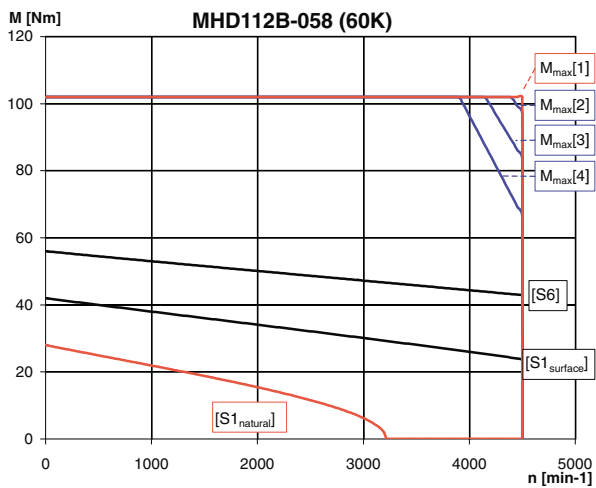
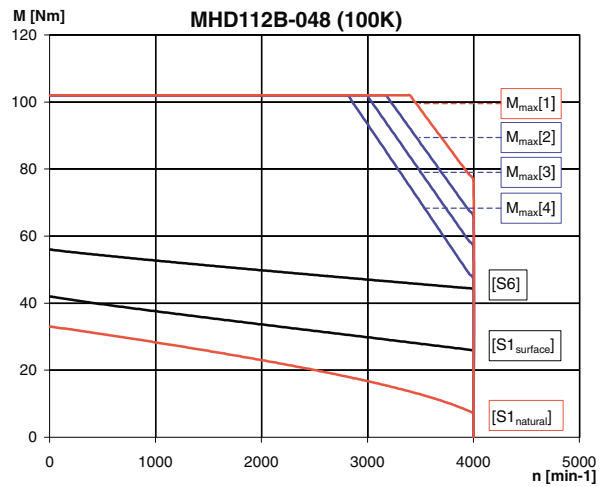
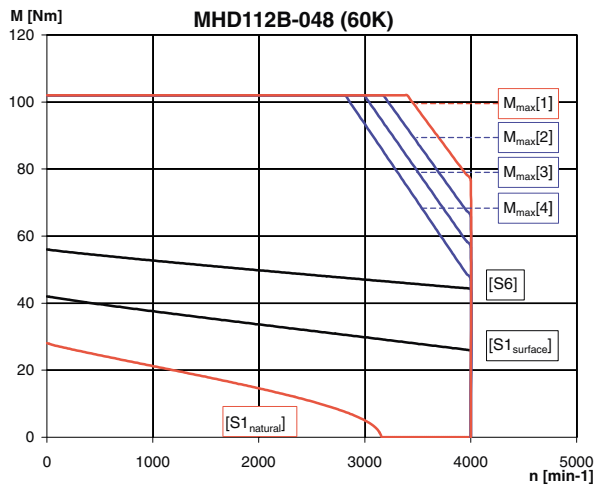
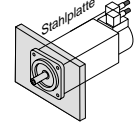

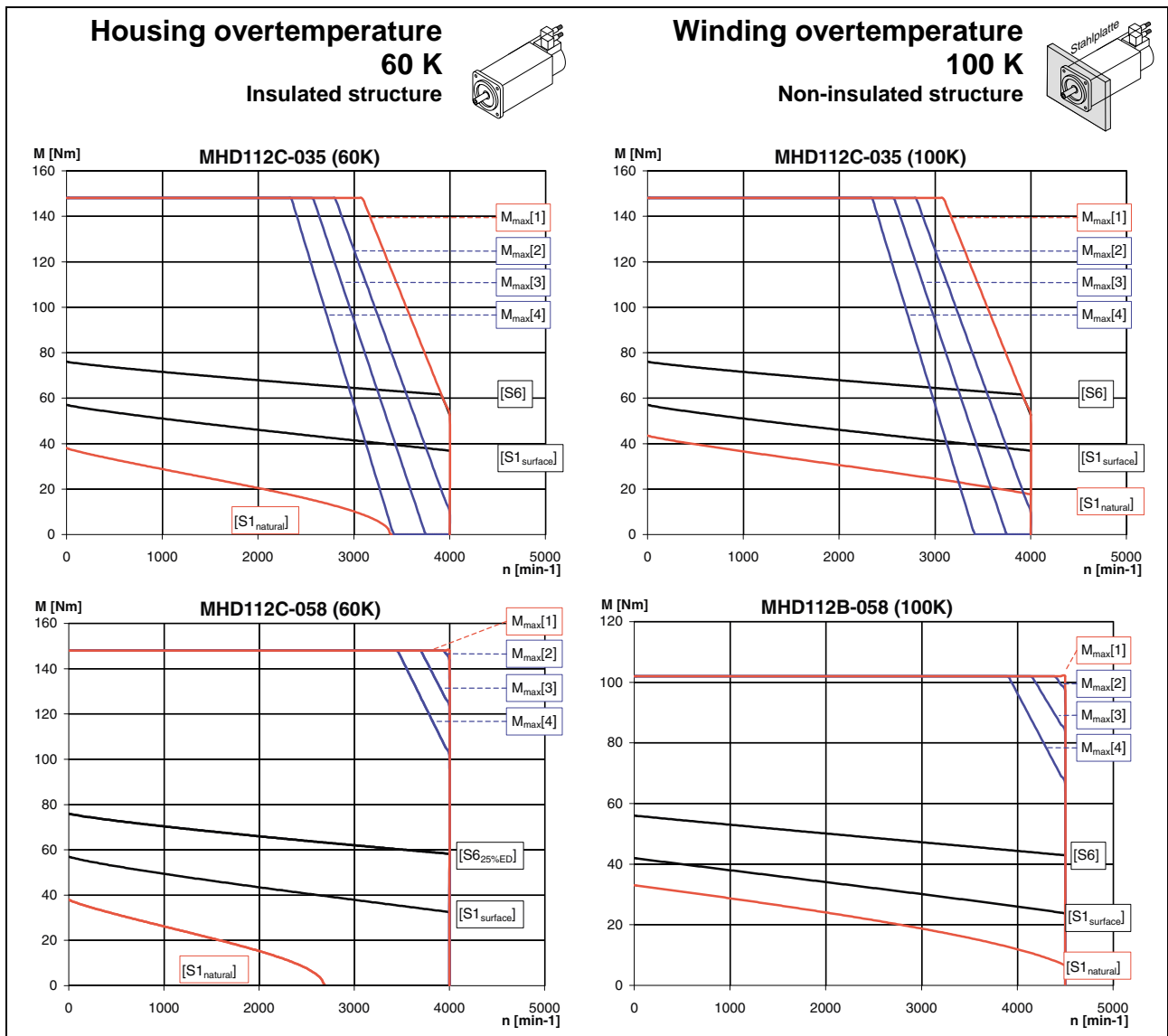

[S1_{natural}]: M_{dN} Natural conv. (S1 continuous operation)
 [S1_{surface}]: M_{dN} Surface cooling (S1 continuous operation)
 [S6]: M_{KB} (S6 intermittent operation)
 M_{max}[1]: HDS to HVR
 M_{max}[2]: HDS to HVE or DKCxx.3 with a power connection of 3 x AC 480 V
 M_{max}[3]: HDS to HVE or DKCxx.3 with a power connection of 3 x AC 440 V
 M_{max}[4]: HDS to HVE or DKCxx.3 with a power connection of 3 x AC 400 V

Fig. 11-17: Characteristic curves

Housing overtemperature 60 K
Insulated structure

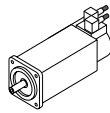

Winding overtemperature 100 K
Non-insulated structure

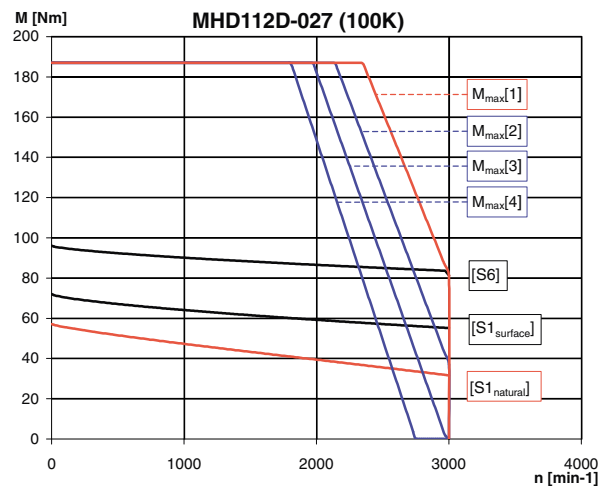
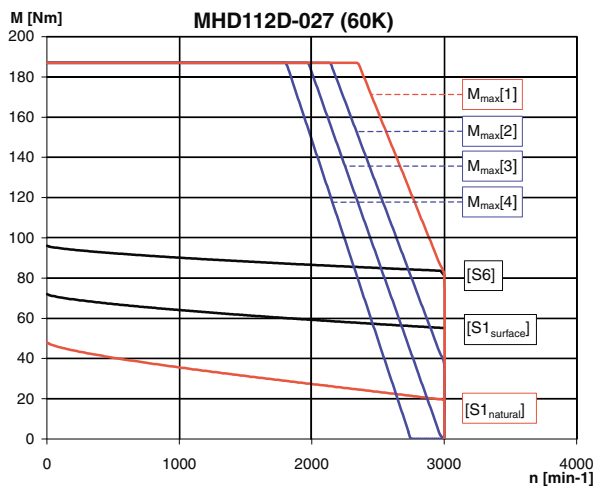
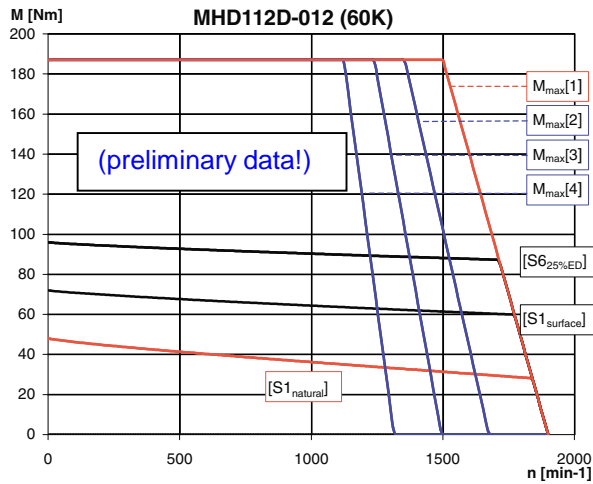
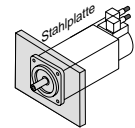

- [S1_{natural}]: M_{dN} Natural conv. (S1 continuous operation)
- [S1_{surface}]: M_{dN} Surface cooling (S1 continuous operation)
- [S6]: M_{KB} (S6 intermittent operation)
- M_{max}[1]**: HDS to HVR
- M_{max}[2]**: HDS to HVE or DKCxx.3 with a power connection of 3 x AC 480 V
- M_{max}[3]**: HDS to HVE or DKCxx.3 with a power connection of 3 x AC 440 V
- M_{max}[4]**: HDS to HVE or DKCxx.3 with a power connection of 3 x AC 400 V

Fig. 11-18: Characteristic curves

11.4 Shaft loads

Permissible maximum radial force $F_{\text{radial_max}}$ and permissible radial force F_{radial}

For explanations refer to Chapter 16.

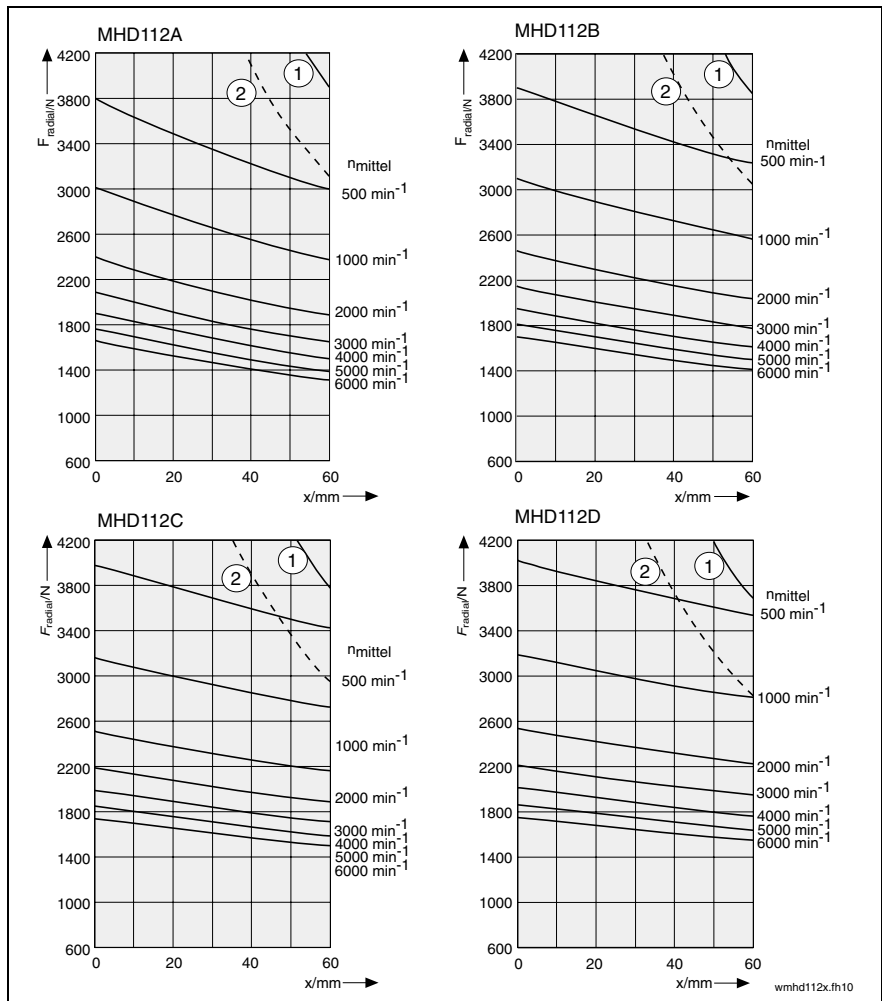

- (1): $F_{\text{radial_max}}$ (plain shaft)
- (2): $F_{\text{radial_max}}$ (shaft with keyway)

Fig. 11-19: MHD112: Permissible maximum radial force $F_{\text{radial_max}}$ and permissible radial force F_{radial}

Permissible axial force F_{axial}

$$F_{\text{axial}} = x \cdot F_{\text{radial}}$$

- x: **0.36** for MHD112A, -B
- x: **0.35** for MHD112C, -D
- F_{axial} : permissible axial force in N
- F_{radial} : permissible radial force in N

Fig. 11-20: MHD112: permissible axial force F_{axial}

11.5 Dimensional Details

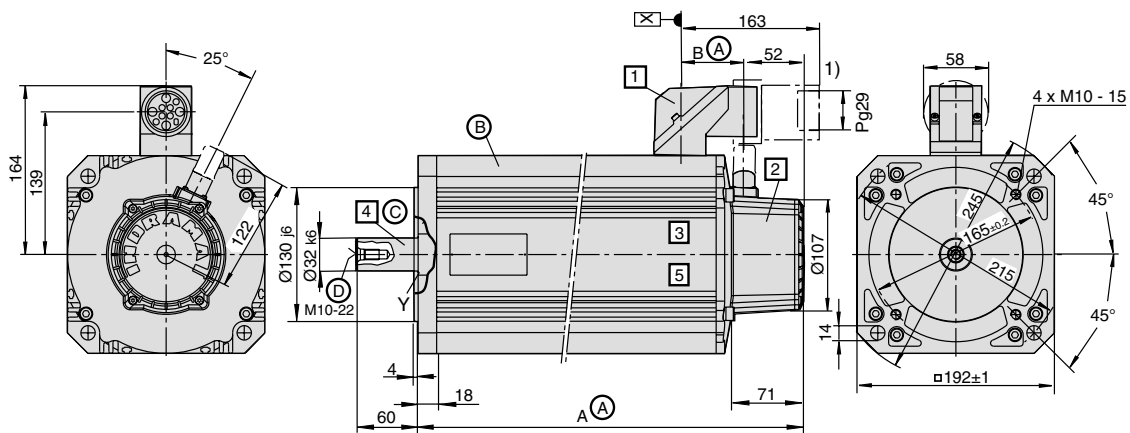

1) Connector not included in the scope of motor delivery

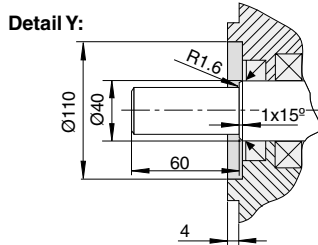

Options:

- 1) Output direction of power connector**
 The output direction of the power connector must be selected when ordering. The following output directions are possible:
- to side A
 - to side B
 - to the right
 - to the left

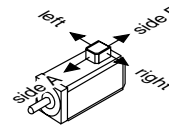

The drawing shows the output direction upon delivery, i.e. to side B. The measures in case of a different output direction are obtained by turning the connector housing theoretically around the X-axis.

(A) Size table

Frame size	Meas. A	Meas. B
MHD 112A	309	67
MHD 112B	375	67
MHD 112C	458	96
MHD 112D	526	96

Measure A: total motor frame length
 Measure B: power connector

- (B)** Motor design according to EN 60034-7, 1996-06, B5 for all installation positions
- (C)**
- Flange according to DIN 42948, ed. 11.65
 - Positional accuracy with regard to true running, axial running and coaxiality to the shaft according to DIN 42955 Tolerance Class R, ed. 12.81
- (D)**
- Shaft end according to DIN 748 Part 3, ed. 07.75, cylindrical
 - Center hole DS M10 according to DIN 332 Part 2, ed. 05.83
 Max. tightening torque for screw 25.0 Nm
 - Vibration severity grade R according to DIN VDE 0530 Part 14, ed. 02.93

- 2) Motor encoder**
- Digital servo feedback (HSF)
 - Digital servo feedback (HSF) with integrated multiturn absolute encoder
 Measures are identical.
- 3) Holding brake**
- Without holding brake
 - With holding brake
 Measures are identical.
- 4) Output shaft**
- Plain shaft (preferred type)
 - With keyway according to DIN 6885 Sheet 1, ed. 08.68
 (Caution! Balanced with entire keyway!)

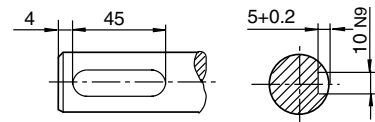

Matching keyway, DIN 6885-A 10 x 8 x 45, Not part of general delivery.

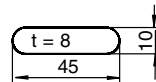

M01MH112.fh10

Fig. 11-21: Dimensional details of MHD112A, MHD112B, MHD112C¹⁾, MHD112D
 1) not applicable to MHD112C-058

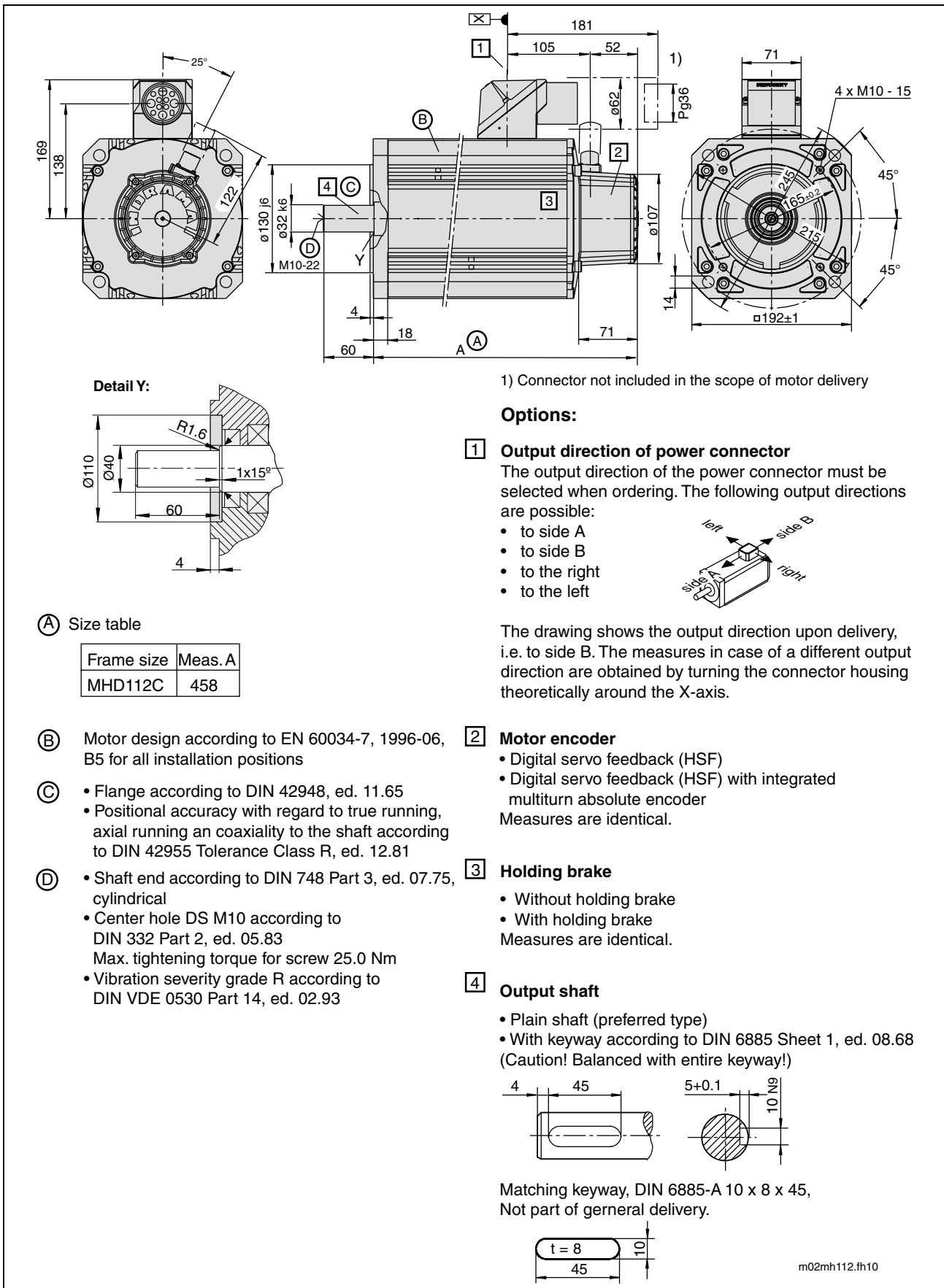

Fig. 11-22: Dimensional details of MHD112C-058

11.6 Blower Units

MHD motors can also be delivered with optional blower units. Please refer to the "Surface" column of the data sheets for performance data of surface-cooled motors. The mechanical dimensions of the blower units are represented in the dimension drawings. The possibilities of combining motor and blower unit and the technical data of the blowers are represented in the table below.

Motor	Ordering name of blower unit			
	LEM – RB112C1XX	LEM – RB112C2XX	LEM – AB112X121	LEM – AB112X221
MHD112A	---	---	x	x
MHD112B, -C, -D	x	x	x	x
--- Blower installation <u>not</u> possible; x Blower installation possible				

Technical data of blower unit			LEM – RB112C1XX	LEM – RB112C2XX	LEM – AB112X121	LEM – AB112X221
Description	Symbol	Unit				
Type of cooling			Radial		axial	
Air flow			B ⇒A blowing		B ⇒A blowing	
Rated voltage	U_n	V	230 V, ±15% 50 / 60 Hz	115 V, ±10% 50 / 60 Hz	230 V, ±15% 50 / 60 Hz	115 V, ±10% 50 / 60 Hz
Power consumption	S_n	VA	45 / 43	40 / 39	45 / 43	40 / 39
Rated current	I	A	0.31 / 0.25	0.53 / 0.46	0.31 / 0.25	0.53 / 0.46
Mean air volume	V	m ³ /h	340	390	340	390
Blower unit mass	m_L	kg	1.2	1.1	1.2	1.1
Noise level		dB(A)	48 / 52	48 / 52	48 / 52	48 / 52

Fig. 11-23: Technical data of MHD112 blower units (optional)

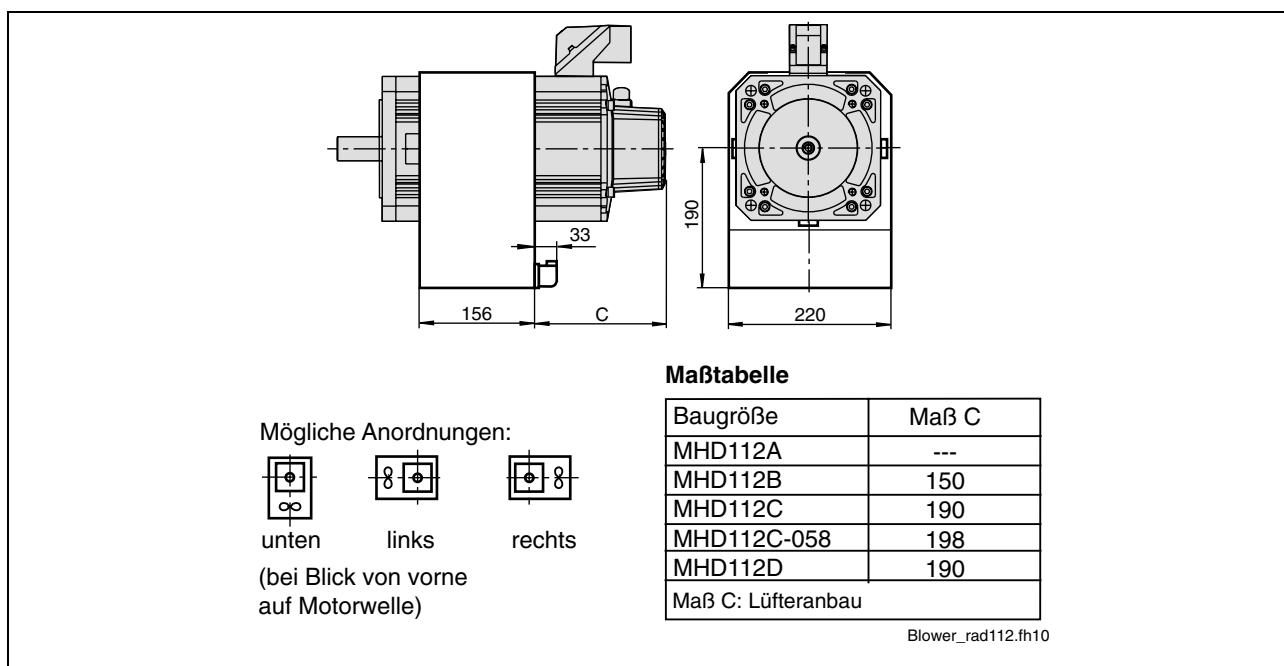
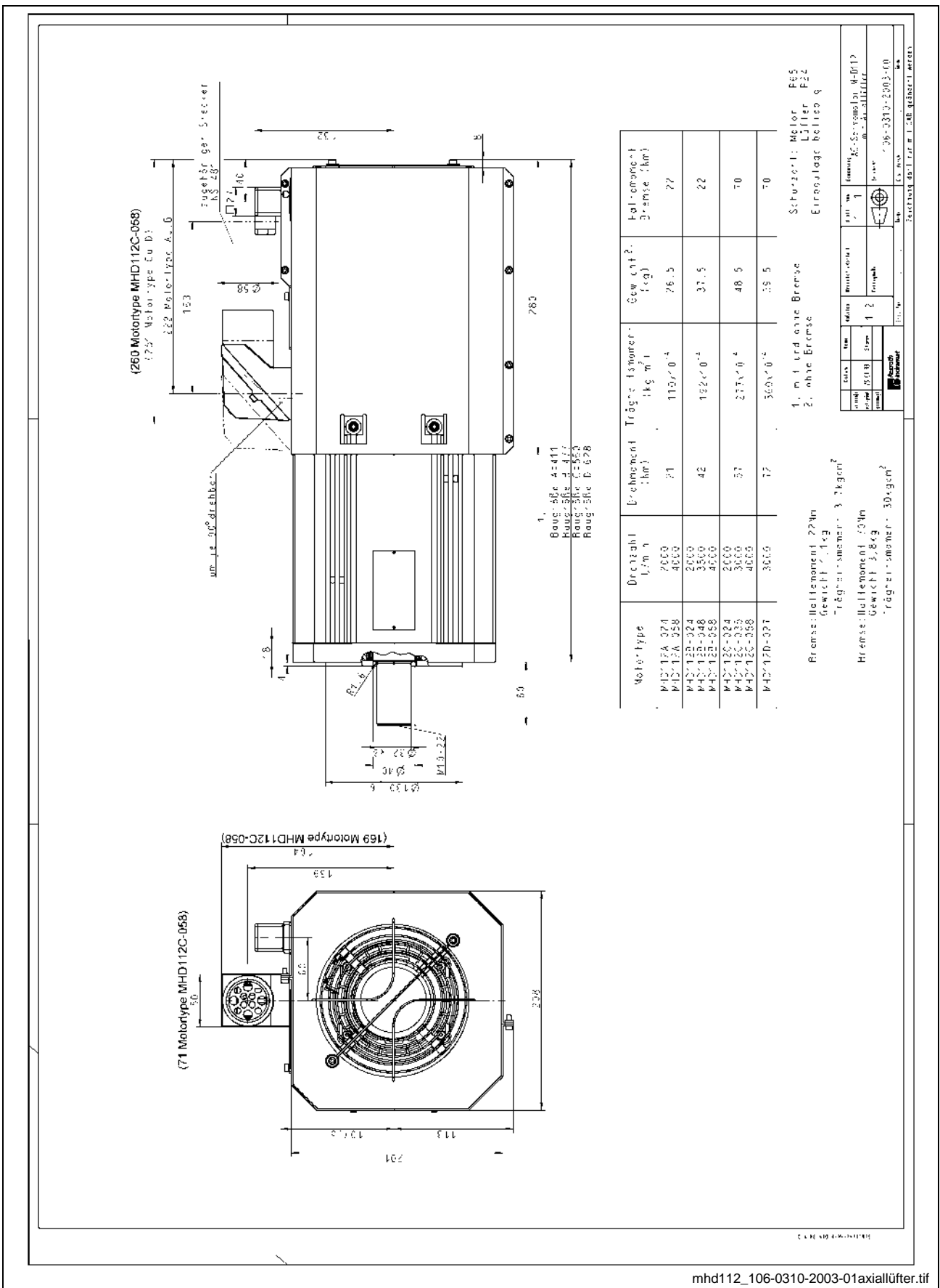

Fig. 11-24: : Dimensional details of MHD112 with radial blower



mhd112_106-0310-2003-01axiallüfter.tif

Fig. 11-25: Dimensional details of MHD112 with axial blower

12 MHD115

12.1 Technical data

Description	Symbol	Unit	MHD115A-024			
			Natural 60K	Natural 100 K	Surface 60 K/100	Liquid 60 K/100
Type of cooling			Natural 60K	Natural 100 K	Surface 60 K/100	Liquid 60 K/100
Motor overtemperature						
Electric parameters						
Characteristic motor speed	n_K	min^{-1}	2000			
Continuous torque at standstill	M_{dN}	Nm	32.0	36.5	48.0	60.8
Continuous current at standstill	I_{dN}	A	21.7	25.0	32.6	41.2
Peak current	I_{max}	A	98.0			
Torque constant at 20 °C ¹⁾	K_m	Nm/A	1.65			
Voltage constant at 20 °C	$K_{E(eff)}$	V/1000min ⁻¹	150.0			
Winding resistance at 20 °C	R12	Ω	0.66			
Winding inductivity	L12	mH	8.6			
Number of pole pairs	p		4			
Rated data ²⁾						
Rated speed	n_N	min^{-1}	2000	2000	2000	2000
Rated torque	M_N	Nm	14.9	24.9	37.5	52.6
Rated current	I_N	A	7.1	12.1	18.0	25.2
Rated performance	P_N	kW	3.8	6.4	9.7	13.8
Rated voltage	U_N	V	309	320	338	365
Rated frequency	f_N	Hz	133	133	133	133
Mechanical parameters						
Moment of inertia of the rotor	J_M	kgm^2	65.0×10^{-4}			
Theoretical maximum torque	M_{max}	Nm	110.0			
Minimum strand cross-section ⁴⁾	S	mm^2	1.5	2.5	4.0	4.0
time constant Zeitkonstante	T_{th}	min	60	60	30	20
Maximum speed	n_{max}	min^{-1}	4000			
Motor mass ^{3) 5)}	m	kg	30.0			
Perm. stor. a. transport temperature	T_L	°C	-20 to +80			
Permissible ambient temperature ⁶⁾	T_{um}	°C	0 to 40			
Maximum setup height ⁶⁾	h	m	1000 above MSL			
Degree of protection ⁷⁾			IP65			
Insulation class (according to DIN VDE 0530 Part 1)			F			
Housing varnish			Prime coat black in a/w RAL 9005			
¹⁾ K_m is to be used for calculations with crest values (I_{dN} , I_{max}). For calculations with root-mean-square values (rated data), the torque constant K_m must be multiplied by a factor of $\sqrt{2}$. ²⁾ Values determined according to EN 60034-1. Current and voltage specified as root-mean-square values. ³⁾ Without holding brake. ⁴⁾ Applicable to Bosch Rexroth cables. Rated according to VDE0298-4 (1992) and installation type B2 according to EN 60204-1 (1993) at an ambient temperature of 40 °C. ⁵⁾ Without fan unit. ⁶⁾ If the limits specified are exceeded, the performance data must be reduced if necessary. For reduction factors, refer to the chapter entitled "Environmental Conditions". ⁷⁾ Provided the power and encoder cables are mounted properly.						

Fig. 12-1: Technical data of MHD115A-024

Description	Symbol	Unit	MHD115A-035			
			Natural 60K	Natural 100 K	Surface 60 K/100	Liquid 60 K/100
Type of cooling						
Motor overtemperature			60K	100 K	60 K/100	60 K/100
Electric parameters						
Characteristic motor speed	n_K	min^{-1}	3000			
Continuous torque at standstill	M_{dN}	Nm	32.0	36.5	48.0	60.8
Continuous current at standstill	I_{dN}	A	26.9	31.5	40.4	51.1
Peak current	I_{max}	A	121.0			
Torque constant at 20 °C ¹⁾	K_m	Nm/A	1.31			
Voltage constant at 20 °C	$K_{E(\text{eff})}$	V/1000min ⁻¹	113.9			
Winding resistance at 20 °C	R12	Ω	0.46			
Winding inductivity	L12	mH	5.8			
Number of pole pairs	p		4			
Rated data ²⁾						
Rated speed	n_N	min^{-1}	3000	3000	3000	3000
Rated torque	M_N	Nm	8.5	21.7	34.8	50.5
Rated current	I_N	A	5.1	13.2	20.7	30.0
Rated performance	P_N	kW	3.0	8.0	12.6	18.4
Rated voltage	U_N	V	345	360	381	417
Rated frequency	f_N	Hz	200	200	200	200
Mechanical parameters						
Moment of inertia of the rotor	J_M	kgm^2	65.0×10^{-4}			
Theoretical maximum torque	M_{max}	Nm	110.0			
Minimum strand cross-section ⁴⁾	S	mm^2	2.5	4.0	4.0	6.0
time constant Zeitkonstante	T_{th}	min	60	60	30	20
Maximum speed	n_{max}	min^{-1}	4500			
Motor mass ^{3) 5)}	m	kg	30.0			
Perm. stor. a. transport temperature	T_L	°C	-20 to +80			
Permissible ambient temperature ⁶⁾	T_{um}	°C	0 to 40			
Maximum setup height ⁶⁾	h	m	1000 above MSL			
Degree of protection ⁷⁾			IP65			
Insulation class (according to DIN VDE 0530 Part 1)			F			
Housing varnish			Prime coat black in a/w RAL 9005			
¹⁾ K_m is to be used for calculations with crest values (I_{dN} , I_{max}). For calculations with root-mean-square values (rated data), the torque constant K_m must be multiplied by a factor of $\sqrt{2}$. ²⁾ Values determined according to EN 60034-1. Current and voltage specified as root-mean-square values. ³⁾ Without holding brake. ⁴⁾ Applicable to Bosch Rexroth cables. Rated according to VDE0298-4 (1992) and installation type B2 according to EN 60204-1 (1993) at an ambient temperature of 40 °C. ⁵⁾ Without fan unit. ⁶⁾ If the limits specified are exceeded, the performance data must be reduced if necessary. For reduction factors, refer to the chapter entitled "Environmental Conditions". ⁷⁾ Provided the power and encoder cables are mounted properly.						

Fig. 12-2: Technical data of MHD115A-035

Description	Symbol	Unit	MHD115A-058			
			Natural 60K	Natural 100 K	Surface 60 K/100	Liquid 60 K/100
Type of cooling						
Motor overtemperature			60K	100 K	60 K/100	60 K/100
Electric parameters						
Characteristic motor speed	n_K	min^{-1}	4000			
Continuous torque at standstill	M_{dN}	Nm	32.0	36.5	48.0	60.8
Continuous current at standstill	I_{dN}	A	36.6	42.1	54.9	69.5
Peak current	I_{max}	A	164.7			
Torque constant at 20 °C ¹⁾	K_m	Nm/A	0.98			
Voltage constant at 20 °C	$K_{E(eff)}$	V/1000min ⁻¹	89.1			
Winding resistance at 20 °C	R12	Ω	0.21			
Winding inductivity	L12	mH	2.88			
Number of pole pairs	p		4			
Rated data ²⁾						
Rated speed	n_N	min^{-1}	2000	3000	3000	3000
Rated torque	M_N	Nm	7.1	12.2	27.8	45.4
Rated current	I_N	A	5.7	10.0	22.5	36.7
Rated performance	P_N	kW	1.8	4.6	10.6	17.5
Rated voltage	U_N	V	180	272	284	305
Rated frequency	f_N	Hz	133	200	200	200
Mechanical parameters						
Moment of inertia of the rotor	J_M	kgm^2	65.0×10^{-4}			
Theoretical maximum torque	M_{max}	Nm	110.0			
Minimum strand cross-section ⁴⁾	S	mm^2	6.0	6.0	10.0	10.0
time constant Zeitkonstante	T_{th}	min	60	60	30	20
Maximum speed	n_{max}	min^{-1}	6000			
Motor mass ^{3) 5)}	m	kg	30.0			
Perm. stor. a. transport temperature	T_L	°C	-20 to +80			
Permissible ambient temperature ⁶⁾	T_{um}	°C	0 to 40			
Maximum setup height ⁶⁾	h	m	1000 above MSL			
Degree of protection ⁷⁾			IP65			
Insulation class (according to DIN VDE 0530 Part 1)			F			
Housing varnish			Prime coat black in a/w RAL 9005			
¹⁾ K_m is to be used for calculations with crest values (I_{dN} , I_{max}). For calculations with root-mean-square values (rated data), the torque constant K_m must be multiplied by a factor of $\sqrt{2}$. ²⁾ Values determined according to EN 60034-1. Current and voltage specified as root-mean-square values. ³⁾ Without holding brake. ⁴⁾ Applicable to Bosch Rexroth cables. Rated according to VDE0298-4 (1992) and installation type B2 according to EN 60204-1 (1993) at an ambient temperature of 40 °C. ⁵⁾ Without fan unit. ⁶⁾ If the limits specified are exceeded, the performance data must be reduced if necessary. For reduction factors, refer to the chapter entitled "Environmental Conditions". ⁷⁾ Provided the power and encoder cables are mounted properly.						

Fig. 12-3: Technical data of MHD115A-058

Description	Symbol	Unit	MHD115B-024			
			Natural 60K	Natural 100 K	Surface 60 K/100	Liquid 60 K/100
Type of cooling						
Motor overtemperature			60K	100 K	60 K/100	60 K/100
Electric parameters						
Characteristic motor speed	n_K	min^{-1}	4000			
Continuous torque at standstill	M_{dN}	Nm	50.0	57.0	75.0	95.0
Continuous current at standstill	I_{dN}	A	32.3	37.9	48.5	61.4
Peak current	I_{max}	A	145.0			
Torque constant at 20 °C ¹⁾	K_m	Nm/A	1.7			
Voltage constant at 20 °C	$K_{E(\text{eff})}$	V/1000min ⁻¹	154.0			
Winding resistance at 20 °C	R12	Ω	0.36			
Winding inductivity	L12	mH	5.3			
Number of pole pairs	p		4			
Rated data ²⁾						
Rated speed	n_N	min^{-1}	2000	2000	2000	2000
Rated torque	M_N	Nm	17.9	32.3	56.1	80.3
Rated current	I_N	A	8.2	15.2	25.7	36.7
Rated performance	P_N	kW	4.4	8.3	14.4	20.4
Rated voltage	U_N	V	313	321	337	360
Rated frequency	f_N	Hz	133	133	133	133
Mechanical parameters						
Moment of inertia of the rotor	J_M	kgm^2	93.2×10^{-4}			
Theoretical maximum torque	M_{max}	Nm	160.0			
Minimum strand cross-section ⁴⁾	S	mm^2	6.0	6.0	6.0	10.0
time constant Zeitkonstante	T_{th}	min	100	100	45	30
Maximum speed	n_{max}	min^{-1}	4000			
Motor mass ^{3) 5)}	m	kg	40.0			
Perm. stor. a. transport temperature	T_L	°C	-20 to +80			
Permissible ambient temperature ⁶⁾	T_{um}	°C	0 to 40			
Maximum setup height ⁶⁾	h	m	1000 above MSL			
Degree of protection ⁷⁾			IP65			
Insulation class (according to DIN VDE 0530 Part 1)			F			
Housing varnish			Prime coat black in a/w RAL 9005			
¹⁾ K_m is to be used for calculations with crest values (I_{dN} , I_{max}). For calculations with root-mean-square values (rated data), the torque constant K_m must be multiplied by a factor of $\sqrt{2}$. ²⁾ Values determined according to EN 60034-1. Current and voltage specified as root-mean-square values. ³⁾ Without holding brake. ⁴⁾ Applicable to Bosch Rexroth cables. Rated according to VDE0298-4 (1992) and installation type B2 according to EN 60204-1 (1993) at an ambient temperature of 40 °C. ⁵⁾ Without fan unit. ⁶⁾ If the limits specified are exceeded, the performance data must be reduced if necessary. For reduction factors, refer to the chapter entitled "Environmental Conditions". ⁷⁾ Provided the power and encoder cables are mounted properly.						

Fig. 12-4: Technical data of MHD115B-024

Description	Symbol	Unit	MHD115B-035			
Type of cooling			Natural	Natural	Surface	Liquid
Motor overtemperature			60K	100 K	60 K/100	60 K/100
Electric parameters						
Characteristic motor speed	n_K	min^{-1}	3000			
Continuous torque at standstill	M_{dN}	Nm	50.0	57.0	75.0	95.0
Continuous current at standstill	I_{dN}	A	43.3	49.4	65.0	82.3
Peak current	I_{max}	A	195.0			
Torque constant at 20 °C ¹⁾	K_m	Nm/A	1.27			
Voltage constant at 20 °C	$K_{E(eff)}$	V/1000min ⁻¹	110.8			
Winding resistance at 20 °C	R12	Ω	0.2			
Winding inductivity	L12	mH	3.01			
Number of pole pairs	p		4			
Rated data ²⁾						
Rated speed	n_N	min^{-1}	2000	2000	2000	2000
Rated torque	M_N	Nm	8.5	25.2	53.1	78.0
Rated current	I_N	A	5.2	15.4	32.5	47.8
Rated performance	P_N	kW	2.0	6.0	12.9	19.1
Rated voltage	U_N	V	223	228	242	261
Rated frequency	f_N	Hz	133	133	133	133
Mechanical parameters						
Moment of inertia of the rotor	J_M	kgm^2	93.0×10^{-4}			
Theoretical maximum torque	M_{max}	Nm	160.0			
Minimum strand cross-section ⁴⁾	S	mm^2	6.0	6.0	10.0	16.0
time constant Zeitkonstante	T_{th}	min	100	100	45	30
Maximum speed	n_{max}	min^{-1}	4500			
Motor mass ^{3) 5)}	m	kg	40.0			
Perm. stor. a. transport temperature	T_L	°C	-20 to +80			
Permissible ambient temperature ⁶⁾	T_{um}	°C	0 to 40			
Maximum setup height ⁶⁾	h	m	1000 above MSL			
Degree of protection ⁷⁾			IP65			
Insulation class (according to DIN VDE 0530 Part 1)			F			
Housing varnish			Prime coat black in a/w RAL 9005			
¹⁾ K_m is to be used for calculations with crest values (I_{dN} , I_{max}). For calculations with root-mean-square values (rated data), the torque constant K_m must be multiplied by a factor of $\sqrt{2}$. ²⁾ Values determined according to EN 60034-1. Current and voltage specified as root-mean-square values. ³⁾ Without holding brake. ⁴⁾ Applicable to Bosch Rexroth cables. Rated according to VDE0298-4 (1992) and installation type B2 according to EN 60204-1 (1993) at an ambient temperature of 40 °C. ⁵⁾ Without fan unit. ⁶⁾ If the limits specified are exceeded, the performance data must be reduced if necessary. For reduction factors, refer to the chapter entitled "Environmental Conditions". ⁷⁾ Provided the power and encoder cables are mounted properly.						

Fig. 12-5: Technical data of MHD115B-035

Description	Symbol	Unit	MHD115B-058			
			Natural 60K	Natural 100 K	Surface 60 K/100	Liquid 60 K/100
Type of cooling						
Motor overtemperature			60K	100 K	60 K/100	60 K/100
Electric parameters						
Characteristic motor speed	n_K	min^{-1}	4000			
Continuous torque at standstill	M_{dN}	Nm	50.0	57.0	75.0	95.0
Continuous current at standstill	I_{dN}	A	62.2	71.6	93.3	118.2
Peak current	I_{max}	A	280.0			
Torque constant at 20 °C ¹⁾	K_m	Nm/A	0.9			
Voltage constant at 20 °C	$K_{E(eff)}$	V/1000min ⁻¹	81.8			
Winding resistance at 20 °C	R12	Ω	0.11			
Winding inductivity	L12	mH	1.6			
Number of pole pairs	p		4			
Rated data ²⁾						
Rated speed	n_N	min^{-1}	1500	1500	4000	4000
Rated torque	M_N	Nm	17.0	33.8	18.1	56.4
Rated current	I_N	A	15.0	30.0	15.9	49.6
Rated performance	P_N	kW	3.2	6.6	9.1	28.6
Rated voltage	U_N	V	125	130	332	358
Rated frequency	f_N	Hz	100	100	267	267
Mechanical parameters						
Moment of inertia of the rotor	J_M	kgm^2	93.2×10^{-4}			
Theoretical maximum torque	M_{max}	Nm	160.0			
Minimum strand cross-section ⁴⁾	S	mm^2	10.0	10.0	16.0	25.0
time constant Zeitkonstante	T_{th}	min	100	100	45	30
Maximum speed	n_{max}	min^{-1}	6000			
Motor mass ^{3) 5)}	m	kg	40.0			
Perm. stor. a. transport temperature	T_L	°C	-20 to +80			
Permissible ambient temperature ⁶⁾	T_{um}	°C	0 to 40			
Maximum setup height ⁶⁾	h	m	1000 above MSL			
Degree of protection ⁷⁾			IP65			
Insulation class (according to DIN VDE 0530 Part 1)			F			
Housing varnish			Prime coat black in a/w RAL 9005			
¹⁾ K_m is to be used for calculations with crest values (I_{dN} , I_{max}). For calculations with root-mean-square values (rated data), the torque constant K_m must be multiplied by a factor of $\sqrt{2}$. ²⁾ Values determined according to EN 60034-1. Current and voltage specified as root-mean-square values. ³⁾ Without holding brake. ⁴⁾ Applicable to Bosch Rexroth cables. Rated according to VDE0298-4 (1992) and installation type B2 according to EN 60204-1 (1993) at an ambient temperature of 40 °C. ⁵⁾ Without fan unit. ⁶⁾ If the limits specified are exceeded, the performance data must be reduced if necessary. For reduction factors, refer to the chapter entitled "Environmental Conditions". ⁷⁾ Provided the power and encoder cables are mounted properly.						

Fig. 12-6: Technical data of MHD115B-058

Description	Symbol	Unit	MHD115C-024			
			Natural 60K	Natural 100 K	Surface 60 K/100	Liquid 60 K/100
Type of cooling						
Motor overtemperature			60K	100 K	60 K/100	60 K/100
Electric parameters						
Characteristic motor speed	n_K	min^{-1}	2000			
Continuous torque at standstill	M_{dN}	Nm	70.0	80.5	105.0	133.0
Continuous current at standstill	I_{dN}	A	47.5	55.1	71.3	90.3
Peak current	I_{max}	A	214.0			
Torque constant at 20 °C ¹⁾	K_m	Nm/A	1.65			
Voltage constant at 20 °C	$K_{E(\text{eff})}$	V/1000min ⁻¹	150.0			
Winding resistance at 20 °C	R12	Ω	0.185			
Winding inductivity	L12	mH	3.0			
Number of pole pairs	p		4			
Rated data ²⁾						
Rated speed	n_N	min^{-1}	1500	2000	2000	2000
Rated torque	M_N	Nm	21.6	26.0	68.6	104.9
Rated current	I_N	A	10.3	12.6	32.9	50.4
Rated performance	P_N	kW	4.1	6.6	17.5	27.0
Rated voltage	U_N	V	228	304	317	334
Rated frequency	f_N	Hz	100	133	133	133
Mechanical parameters						
Moment of inertia of the rotor	J_M	kgm^2	138×10^{-4}			
Theoretical maximum torque	M_{max}	Nm	231			
Minimum strand cross-section ⁴⁾	S	mm^2	6.0	10.0	10.0	16.0
time constant Zeitkonstante	T_{th}	min	100	100	45	30
Maximum speed	n_{max}	min^{-1}	4000			
Motor mass ^{3) 5)}	m	kg	55.0			
Perm. stor. a. transport temperature	T_L	°C	-20 to +80			
Permissible ambient temperature ⁶⁾	T_{um}	°C	0 to 40			
Maximum setup height ⁶⁾	h	m	1000 above MSL			
Degree of protection ⁷⁾			IP65			
Insulation class (according to DIN VDE 0530 Part 1)			F			
Housing varnish			Prime coat black in a/w RAL 9005			
¹⁾ K_m is to be used for calculations with crest values (I_{dN} , I_{max}). For calculations with root-mean-square values (rated data), the torque constant K_m must be multiplied by a factor of $\sqrt{2}$. ²⁾ Values determined according to EN 60034-1. Current and voltage specified as root-mean-square values. ³⁾ Without holding brake. ⁴⁾ Applicable to Bosch Rexroth cables. Rated according to VDE0298-4 (1992) and installation type B2 according to EN 60204-1 (1993) at an ambient temperature of 40 °C. ⁵⁾ Without fan unit. ⁶⁾ If the limits specified are exceeded, the performance data must be reduced if necessary. For reduction factors, refer to the chapter entitled "Environmental Conditions". ⁷⁾ Provided the power and encoder cables are mounted properly.						

Fig. 12-7: Technical data of MHD115C-024

Description	Symbol	Unit	MHD115C-035			
			Natural 60K	Natural 100 K	Surface 60 K/100	Liquid 60 K/100
Type of cooling						
Motor overtemperature			60K	100 K	60 K/100	60 K/100
Electric parameters						
Characteristic motor speed	n_K	min^{-1}	3000			
Continuous torque at standstill	M_{dN}	Nm	70.0	80.5	105.0	133.0
Continuous current at standstill	I_{dN}	A	58.8	67.6	88.2	111.7
Peak current	I_{max}	A	265.0			
Torque constant at 20 °C ¹⁾	K_m	Nm/A	1.31			
Voltage constant at 20 °C	$K_{E(\text{eff})}$	V/1000min ⁻¹	113.8			
Winding resistance at 20 °C	R12	Ω	0.12			
Winding inductivity	L12	mH	1.96			
Number of pole pairs	p		4			
Rated data ²⁾						
Rated speed	n_N	min^{-1}	1000	2000	2000	2000
Rated torque	M_N	Nm	35.6	25.2	61.6	99.9
Rated current	I_N	A	21.2	15.0	36.6	59.3
Rated performance	P_N	kW	4.3	6.0	14.7	24.1
Rated voltage	U_N	V	118	231	240	254
Rated frequency	f_N	Hz	67	133	133	133
Mechanical parameters						
Moment of inertia of the rotor	J_M	kgm^2	138.0×10^{-4}			
Theoretical maximum torque	M_{max}	Nm	231			
Minimum strand cross-section ⁴⁾	S	mm^2	10.0	10.0	16.0	25.0
time constant Zeitkonstante	T_{th}	min	100	100	45	30
Maximum speed	n_{max}	min^{-1}	4500			
Motor mass ^{3) 5)}	m	kg	55.8			
Perm. stor. a. transport temperature	T_L	°C	-20 to +80			
Permissible ambient temperature ⁶⁾	T_{um}	°C	0 to 40			
Maximum setup height ⁶⁾	h	m	1000 above MSL			
Degree of protection ⁷⁾			IP65			
Insulation class (according to DIN VDE 0530 Part 1)			F			
Housing varnish			Prime coat black in a/w RAL 9005			
¹⁾ K_m is to be used for calculations with crest values (I_{dN} , I_{max}). For calculations with root-mean-square values (rated data), the torque constant K_m must be multiplied by a factor of $\sqrt{2}$. ²⁾ Values determined according to EN 60034-1. Current and voltage specified as root-mean-square values. ³⁾ Without holding brake. ⁴⁾ Applicable to Bosch Rexroth cables. Rated according to VDE0298-4 (1992) and installation type B2 according to EN 60204-1 (1993) at an ambient temperature of 40 °C. ⁵⁾ Without fan unit. ⁶⁾ If the limits specified are exceeded, the performance data must be reduced if necessary. For reduction factors, refer to the chapter entitled "Environmental Conditions". ⁷⁾ Provided the power and encoder cables are mounted properly.						

Fig. 12-8: Technical data of MHD115C-035

Description	Symbol	Unit	MHD115C-058			
			Natural 60K	Natural 100 K	Surface 60 K/100	Liquid 60 K/100
Type of cooling						
Motor overtemperature			60K	100 K	60 K/100	60 K/100
Electric parameters						
Characteristic motor speed	n_K	min^{-1}	4000			
Continuous torque at standstill	M_{dN}	Nm	70.0	80.5	105.0	133.0
Continuous current at standstill	I_{dN}	A	82.5	95.6	123.8	156.8
Peak current	I_{max}	A	371			
Torque constant at 20 °C ¹⁾	K_m	Nm/A	0.95			
Voltage constant at 20 °C	$K_{E(\text{eff})}$	V/1000 min^{-1}	86.4			
Winding resistance at 20 °C	R12	Ω	0.06			
Winding inductivity	L12	mH	0.9			
Number of pole pairs	p		4			
Rated data ²⁾						
Rated speed	n_N	min^{-1}	1000	1000	2000	2000
Rated torque	M_N	Nm	19.2	50.8	30.7	82.0
Rated current	I_N	A	16.0	42.7	25.6	68.4
Rated performance	P_N	kW	2.4	6.6	7.7	20.9
Rated voltage	U_N	V	88	90	175	184
Rated frequency	f_N	Hz	67	67	133	133
Mechanical parameters						
Moment of inertia of the rotor	J_M	kgm^2	138×10^{-4}			
Theoretical maximum torque	M_{max}	Nm	231			
Minimum strand cross-section ⁴⁾	S	mm^2	16.0	16.0	25.0	35.0
time constant Zeitkonstante	T_{th}	min	100	100	45	30
Maximum speed	n_{max}	min^{-1}	6000			
Motor mass ^{3) 5)}	m	kg	55.0			
Perm. stor. a. transport temperature	T_L	°C	-20 to +80			
Permissible ambient temperature ⁶⁾	T_{um}	°C	0 to 40			
Maximum setup height ⁶⁾	h	m	1000 above MSL			
Degree of protection ⁷⁾			IP65			
Insulation class (according to DIN VDE 0530 Part 1)			F			
Housing varnish			Prime coat black in a/w RAL 9005			
¹⁾ K_m is to be used for calculations with crest values (I_{dN} , I_{max}). For calculations with root-mean-square values (rated data), the torque constant K_m must be multiplied by a factor of $\sqrt{2}$. ²⁾ Values determined according to EN 60034-1. Current and voltage specified as root-mean-square values. ³⁾ Without holding brake. ⁴⁾ Applicable to Bosch Rexroth cables. Rated according to VDE0298-4 (1992) and installation type B2 according to EN 60204-1 (1993) at an ambient temperature of 40 °C. ⁵⁾ Without fan unit. ⁶⁾ If the limits specified are exceeded, the performance data must be reduced if necessary. For reduction factors, refer to the chapter entitled "Environmental Conditions". ⁷⁾ Provided the power and encoder cables are mounted properly.						

Fig. 12-9: Technical data of MHD115C-058

Holding brake

Description	Symbol	Unit	Holding brake data
Motor type			MHD115
Holding torque	M_4	Nm	70.0
Rated voltage	U_N	V	DC 24 ± 10%
Rated current	I_N	A	1.29
Moment of inertia	J_B	Kgm ²	30×10^{-4}
Connection time	t_1	ms	53
Disconnection time	t_2	ms	97
Mass	m_B	kg	3.8

Fig. 12-10: Technical data of MHD115 holding brake (optional)

Technical Data liquid coolant

Description	Symbol	Unit	Data		
			MHD115A	MHD115B	MHD115C
motor type			MHD115A	MHD115B	MHD115C
Nominal power loss	P_{vN}	W	1100	1200	1300
Coolant inlet temperature ¹⁾	$\vartheta_{###\text{ein}}$	°C	+10 ... +40		
Coolant temperature raise at P_{vN}	$\Delta\vartheta_N$	°C	10		
Minimum necessary coolant discharge at $\Delta\vartheta_N$ ²⁾	Q_N	l/min	1.5	1.7	1.8
Pressure decrease at Q_N ²⁾³⁾	Δp_N	bar	0.8	0.9	1.0
Maximum system pressure	p_{\max}	bar	3.0		
Volume liquid cooling duct	V	l	0.09	0.11	0.14
pH-value coolant			6 - 8		
Materials with coolant contact			Description		
Flange, end shield			Al Mg 5 F32		
Profile			Al Mg Si 0,5 F22		
O-ring			Viton		
1) Notice the combination between coolant inlet temperature and real environmental temperature: the coolant inlet temperature should be max. 5°C under the real environmental temperature (otherwise danger of condensation exists)! 2) at coolant water 3) for deviating discharge values notice the discharge diagram (see chapter 16.5)					

Fig. 12-11: Technical data liquid coolant at MHD115

12.2 Type Code – Ordering Name

Abbrev. Column	1	2	3	4	5	6	7	8	9	0	1	2	3	4	5	6	7	8	9	0	1	2	3	4	5	6	7	8	9	0	
Example:	M	H	D	1	1	5	B	-	0	2	4	-	N	G	0	-	B	N													

- 1. Product**
 - 1.1 MHD = MHD

- 2. Motor size**
 - 2.1 115 = 115

- 3. Motor length**
 - 3.1 Lengths = A, B, C

- 4. Windings code**
 - 4.1 MHD115A = 024, 035, 058, 059
 - 4.2 MHD115B = 024, 035, 058, 059
 - 4.3 MHD115C = 024, 035, 058, 059

- 5. Motor encoder**
 - 5.1 digital servo feedback. = N
 - 5.2 digital servo feedback with integrated multiturm absolute encoder. = P

- 6. Driven shaft**
 - 6.1 plain shaft (with shaft sealing ring). = G
 - 6.2 Shaft with key per DIN 6885-1 (with shaft sealing ring) = P

- 7. Holding brake**
 - 7.1 without holding brake = 0
 - 7.2 with holding brake 70 Nm = 1

- 8. Output direction of power connection ①**
 - 8.1 Connector to side A = A
 - 8.2 Connector to side B. = B
 - 8.3 Connector to the left = L
 - 8.4 Connector to the right = R

- 9. Housing type**
 - 9.1 for natural convection and surface cooling. = A
 - 9.2 for natural convection and liquid cooling. = N

- 10. Standard reference**

<u>Standard</u>	<u>Title</u>	<u>Edition</u>
DIN 6885-1	Drive Type Fastenings without Taper Action; Parallel Keys, Keyways, Deep Pattern	1968-08

Note:
 ① Looking from front onto driven shaft

t_mhd115_M11en.fh10

Fig. 12-12: Type code MHD115

12.3 Speed-Torque Curves

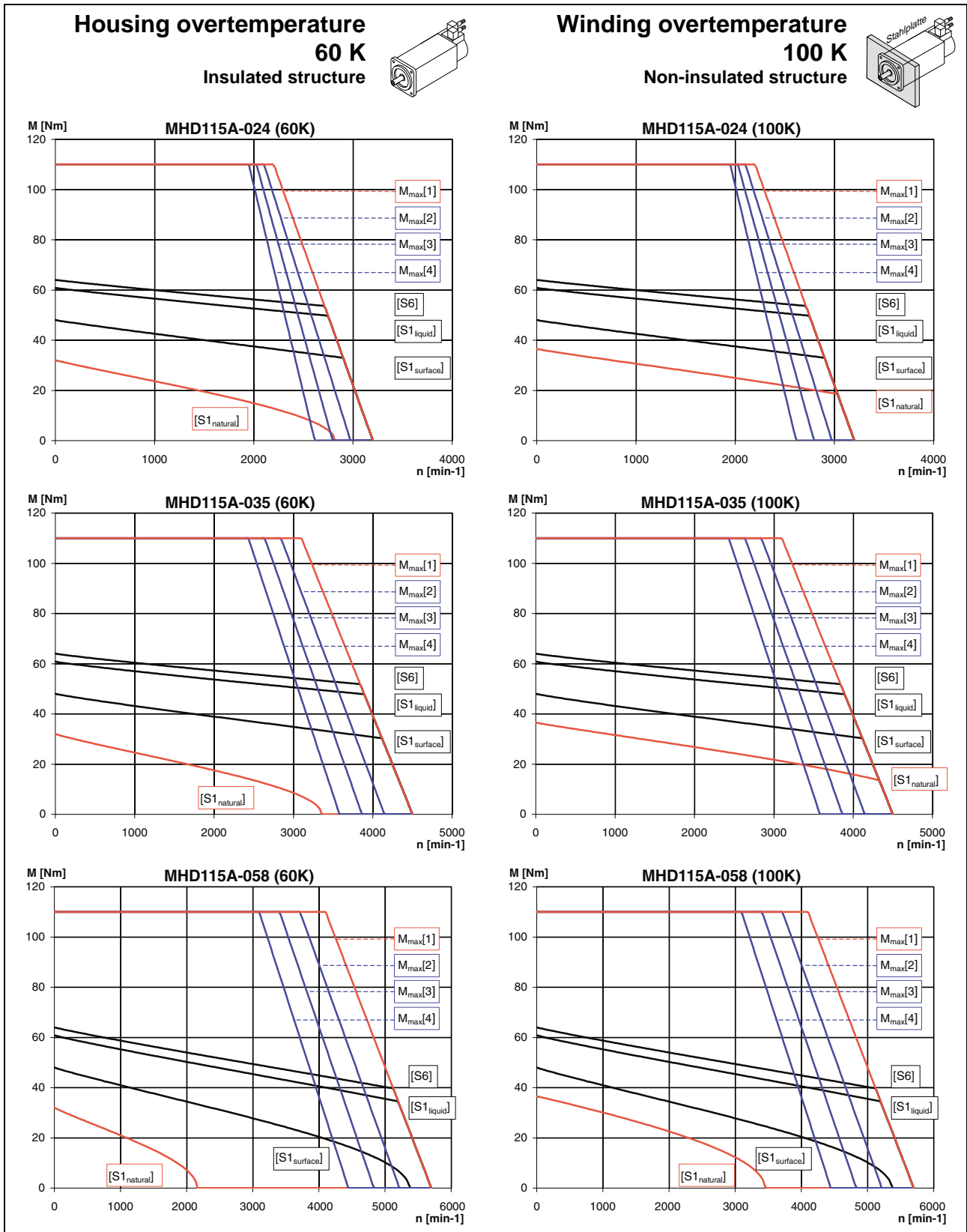

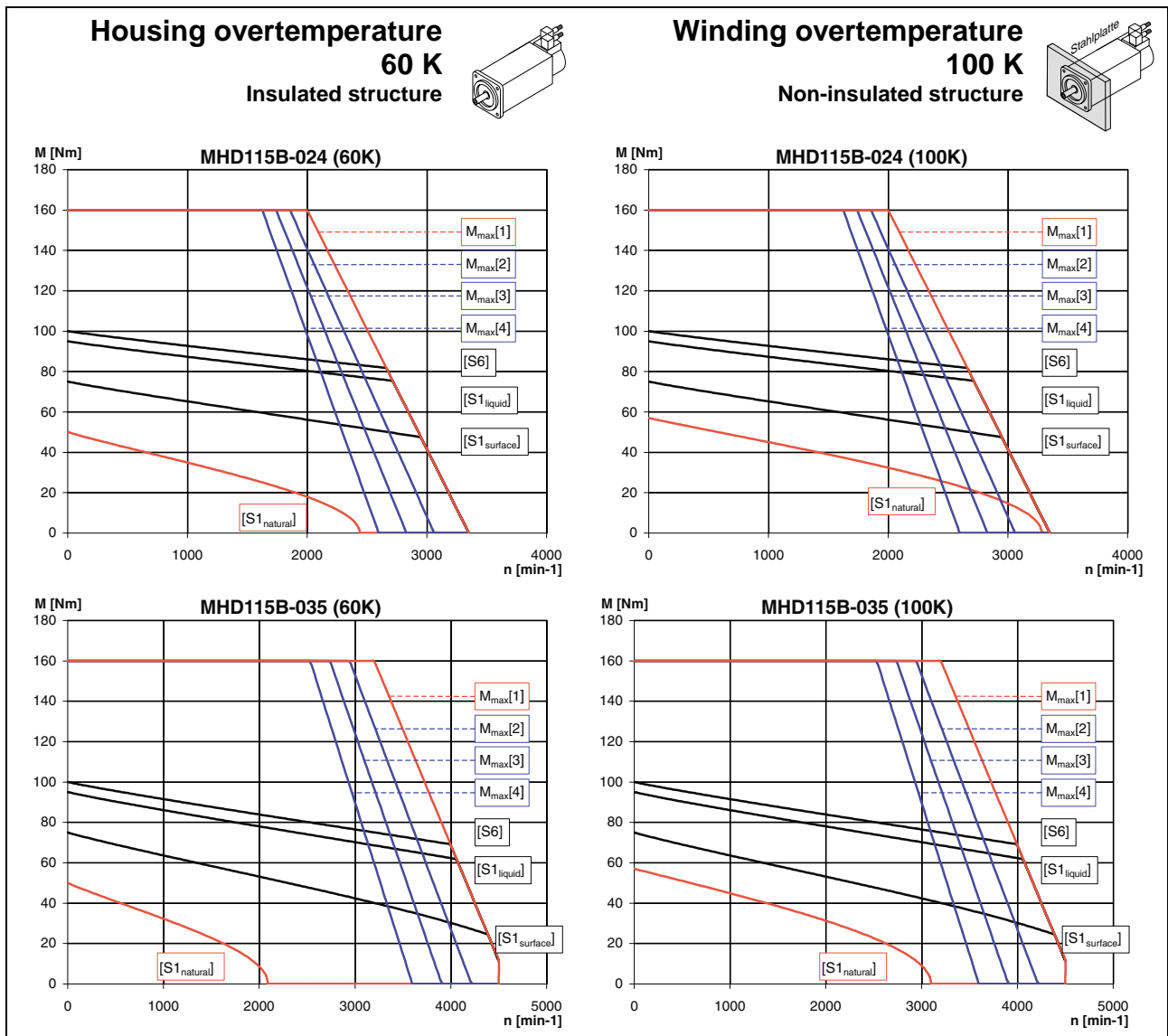

[S1_{natural}]: M_{dN} Natural conv. (S1 continuous operation)
 [S1_{surface}]: M_{dN} Surface cooling (S1 continuous operation)
 [S1_{liquid}]: M_{dN} Liquid cooling (S1 continuous operation)
 [S6]: M_{KB} (S6 intermittent operation)
 M_{max}[1]: HDS to HVR
 M_{max}[2]: HDS to HVE or DKCxx.3 with a power connection of 3 x AC 480 V
 M_{max}[3]: HDS to HVE or DKCxx.3 with a power connection of 3 x AC 440 V
 M_{max}[4]: HDS to HVE or DKCxx.3 with a power connection of 3 x AC 400 V

Fig. 12-13: Characteristic curves

Housing overtemperature 60 K
Insulated structure

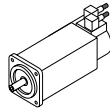

Winding overtemperature 100 K
Non-insulated structure

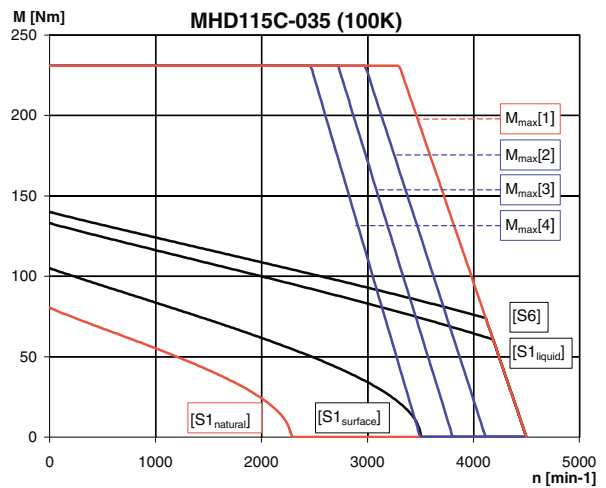
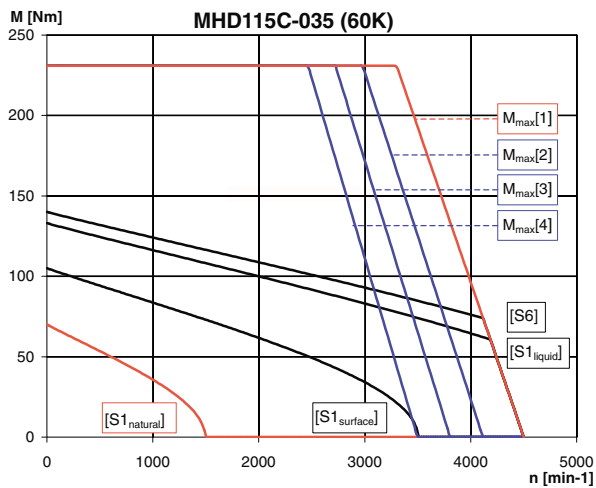
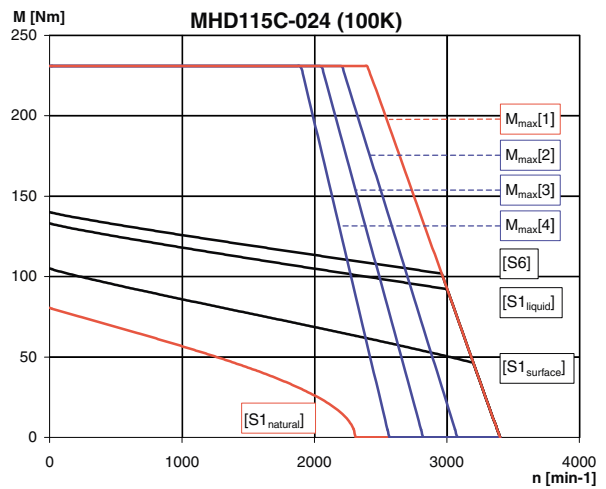
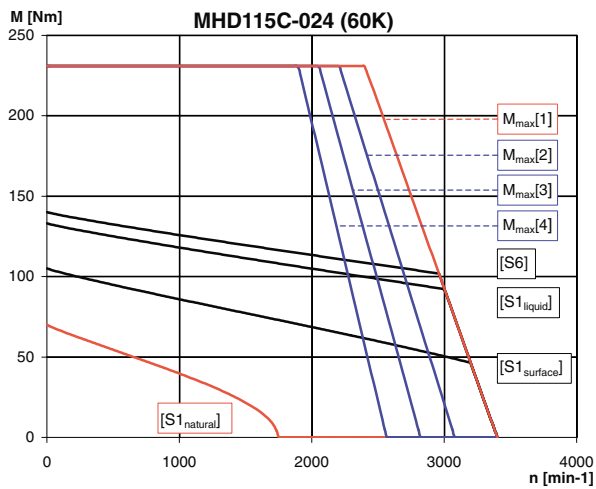
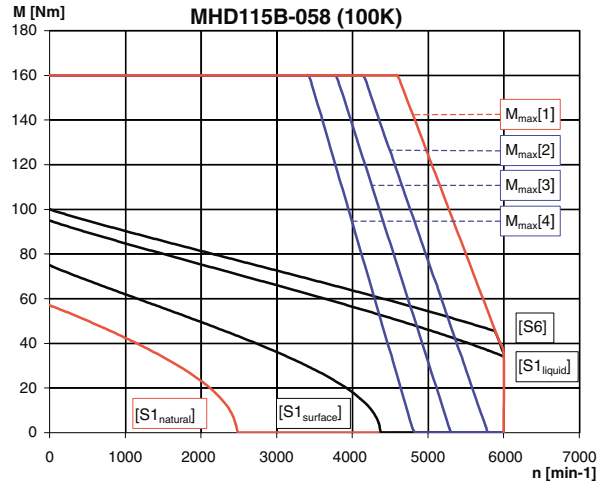
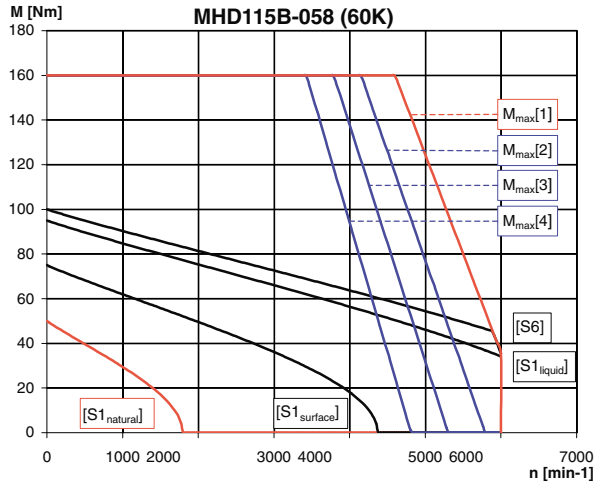
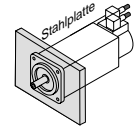

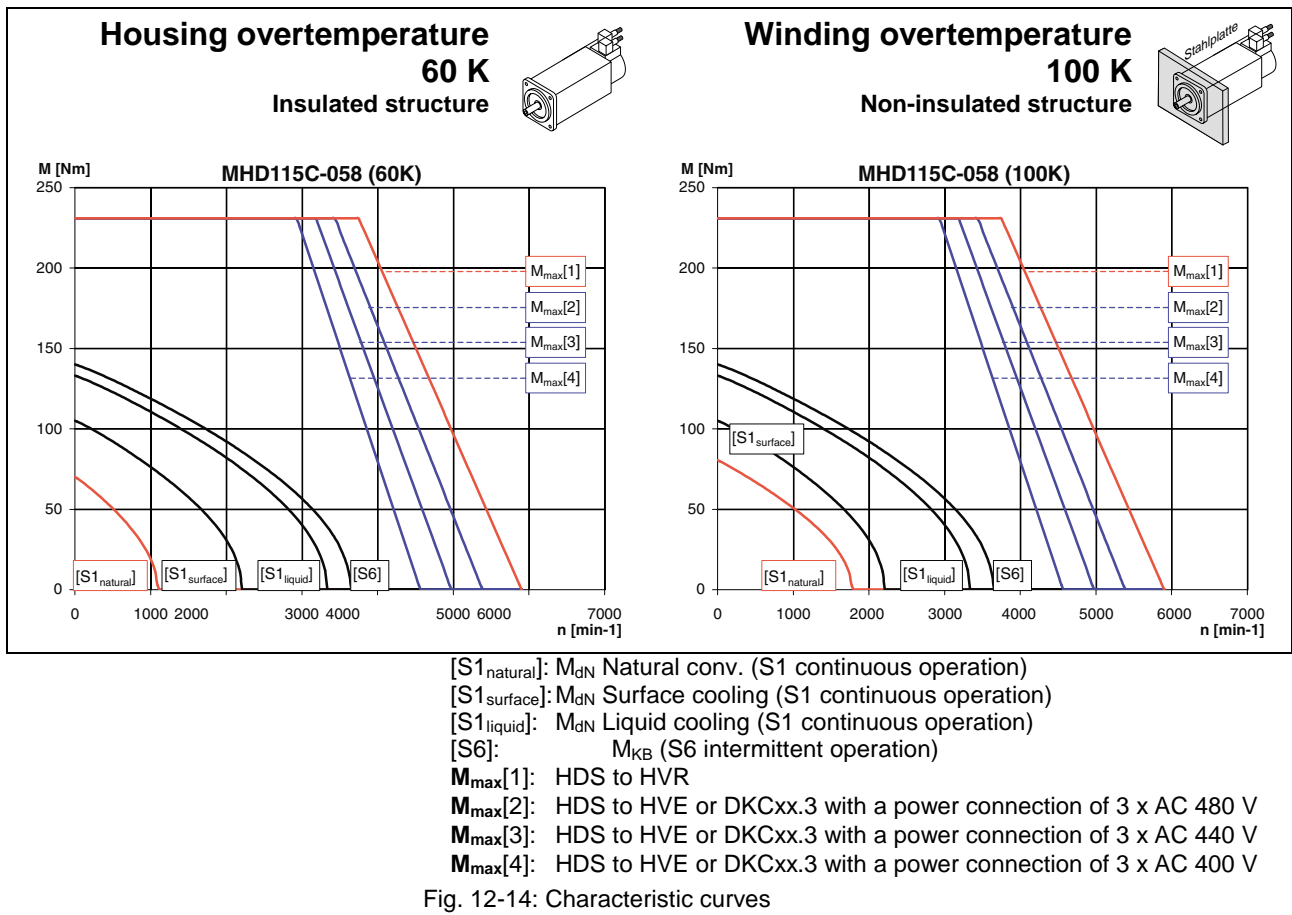

12.4 Shaft loads

Permissible maximum radial force $F_{\text{radial_max}}$ and permissible radial force F_{radial}

For explanations refer to Chapter 16.

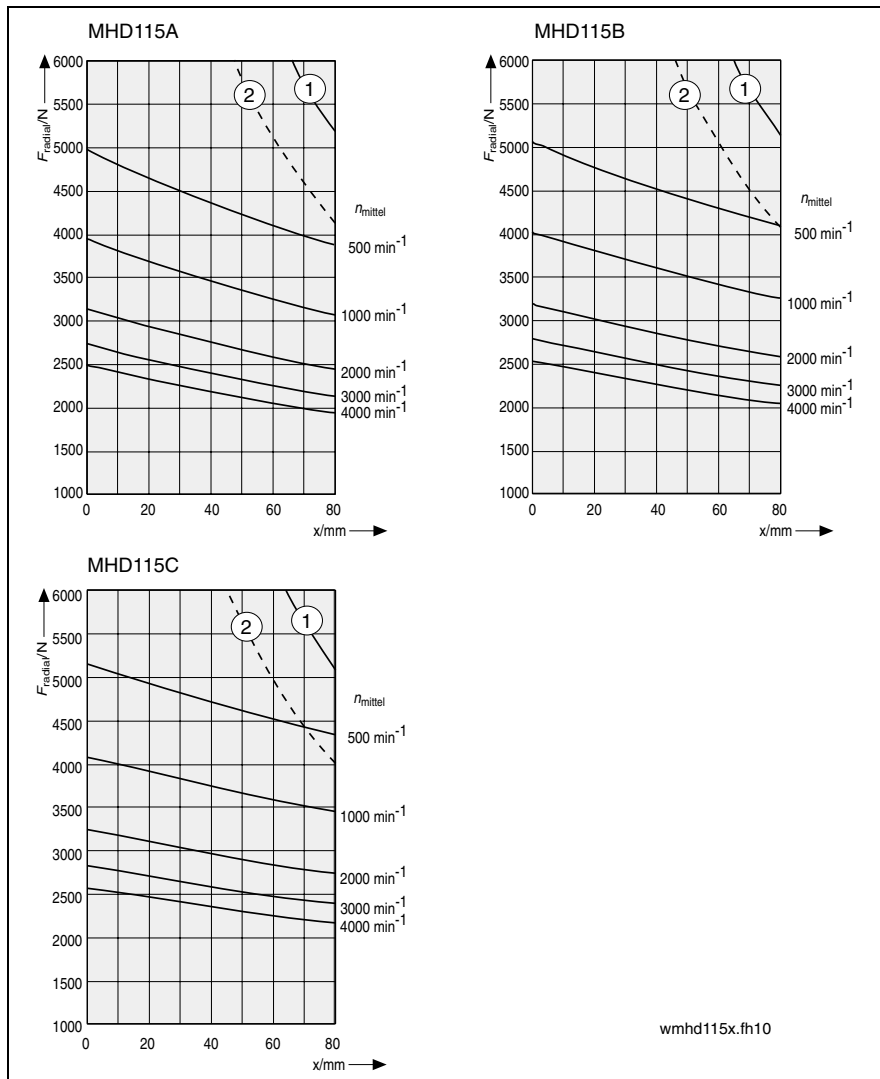

- (1): $F_{\text{radial_max}}$ (plain shaft)
- (2): $F_{\text{radial_max}}$ (shaft with keyway)

Fig. 12-15: MHD115: Permissible maximum radial force $F_{\text{radial_max}}$ and permissible radial force F_{radial}

Permissible axial force F_{axial}

$$F_{\text{axial}} = x \cdot F_{\text{radial}}$$

- x: **0.26** for MHD112A, -B, -C
- F_{axial} : permissible axial force in N
- F_{radial} : permissible radial force in N

Fig. 12-16: MHD115: permissible axial force F_{axial}

12.5 Dimensional Details

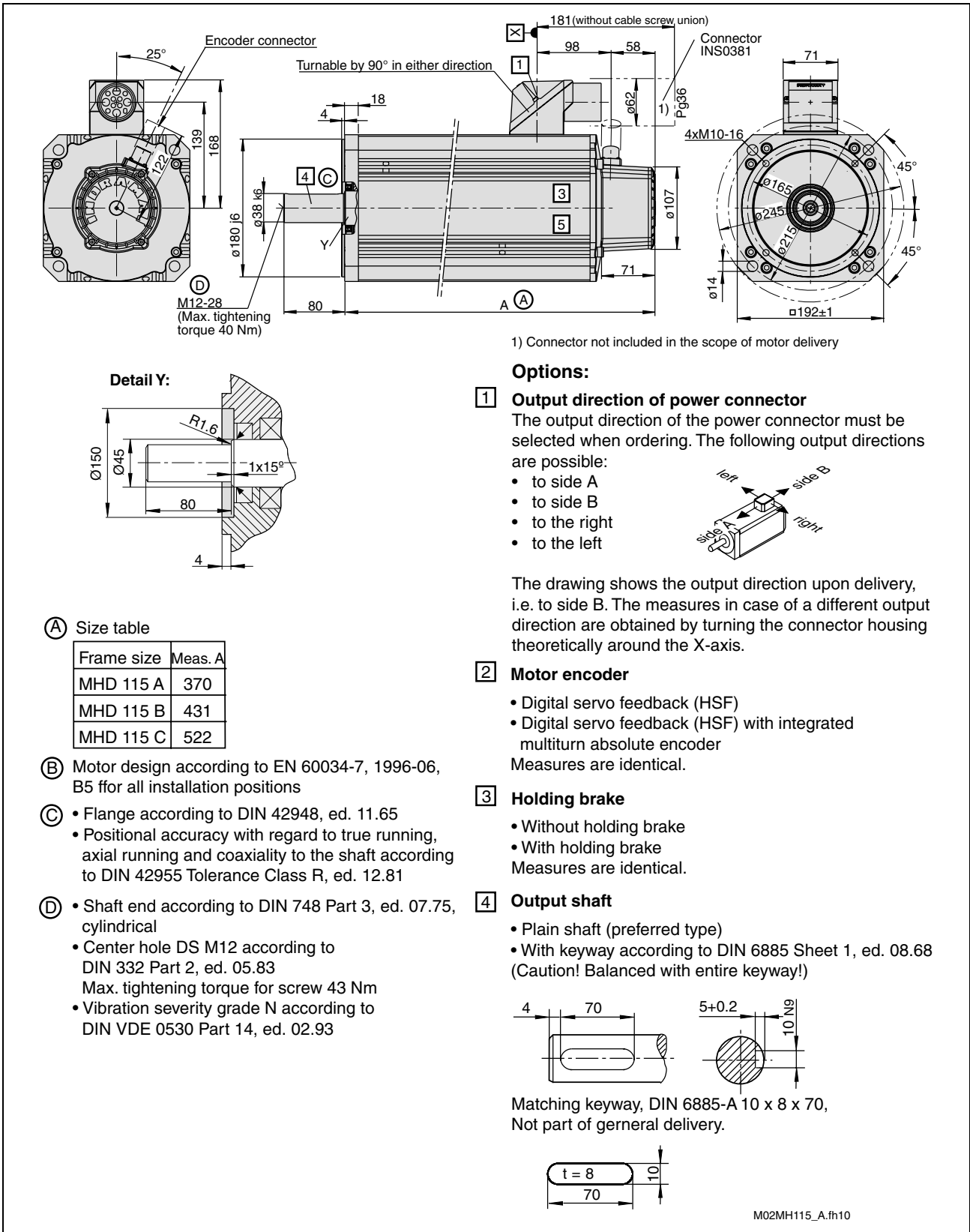

Fig. 12-17: Dimensional details of MHD115.-...-A

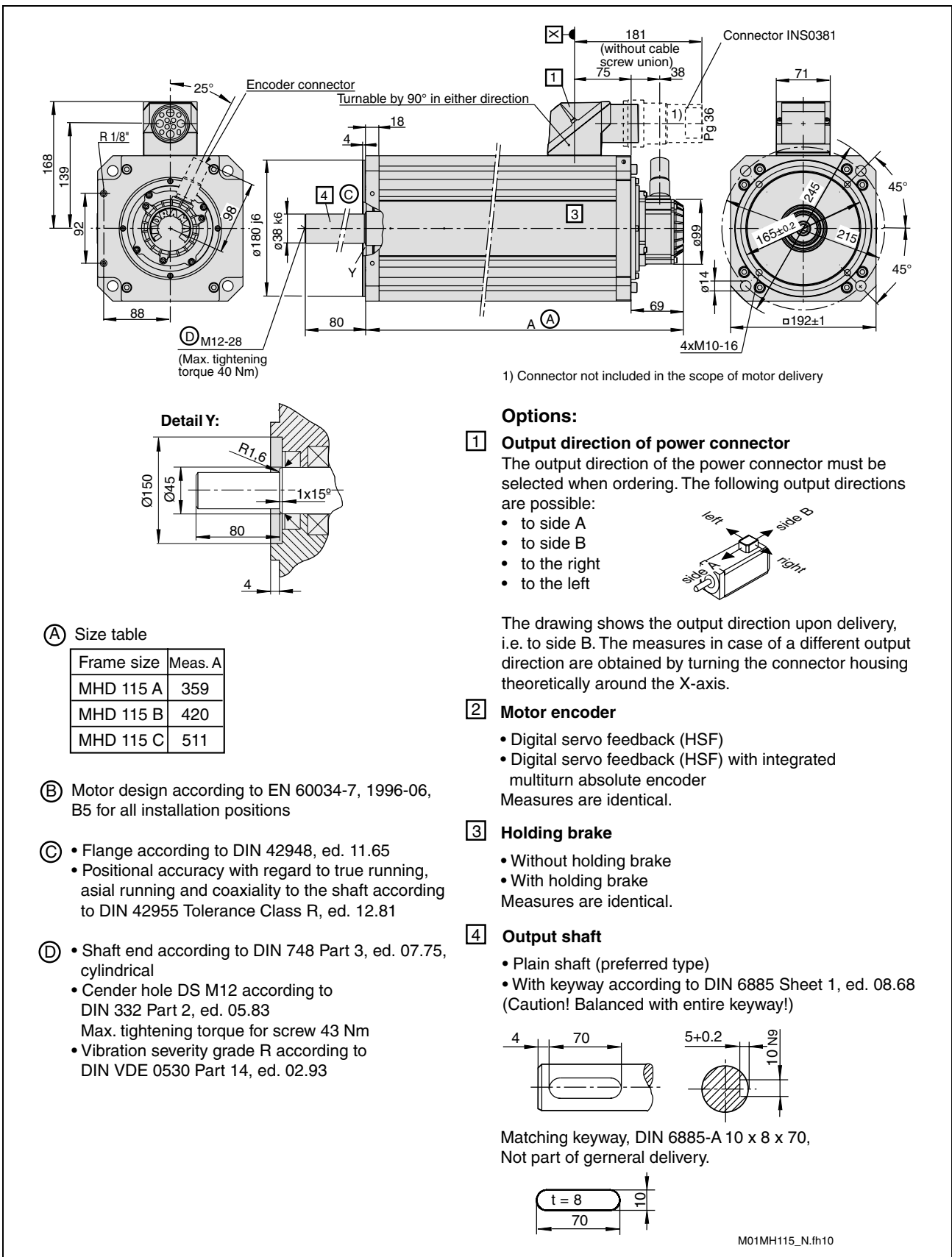

Fig. 12-18: Dimensional details of MHD115.-...-N

12.6 Blower Units

MHD motors can also be delivered with optional fan units. Please refer to the "Surface" column of the data sheets for performance data of surface-cooled motors. The mechanical dimensions of the fan units are represented in the dimension drawings. The possibilities of combining motor and fan unit and the technical data of the fans are represented in the table below.

Motor	Ordering name of fan unit			
	LEM – RB112C1XX	LEM – RB112C2XX	LEM – AB112X121	LEM – AB112X221
MHD115A-xxx-xxx-Axxxx	---	---	x	x
MHD115B-xxx-xxx-Axxxx	x	x	x	x
MHD115C-xxx-xxx-Axxxx	x	x	x	x
--- Fan installation <u>not</u> possible; x Fan installation possible				

Technical data of fan unit			LEM – RB112C1XX	LEM – RB112C2XX	LEM – AB112X121	LEM – AB112X221
Description	Symbol	Unit				
Type of cooling			Radial		axial	
Air flow			B ⇒A blowing		B ⇒A blowing	
Rated voltage	U _n	V	230 V, ±15% 50 / 60 Hz	115 V, ±10% 50 / 60 Hz	230 V, ±15% 50 / 60 Hz	115 V, ±10% 50 / 60 Hz
Power consumption	S _n	VA	45 / 43	40 / 39	45 / 43	40 / 39
Rated current	I	A	0.31 / 0.25	0.53 / 0.46	0.31 / 0.25	0.53 / 0.46
Mean air volume	V	m ³ /h	340	390	340	390
Fan unit mass	m _L	kg	1.2	1.1	1.2	1.1
Noise level		dB(A)	48 / 52	48 / 52	48 / 52	48 / 52

Fig. 12-19: Technical data of MHD115 fan units (optional)

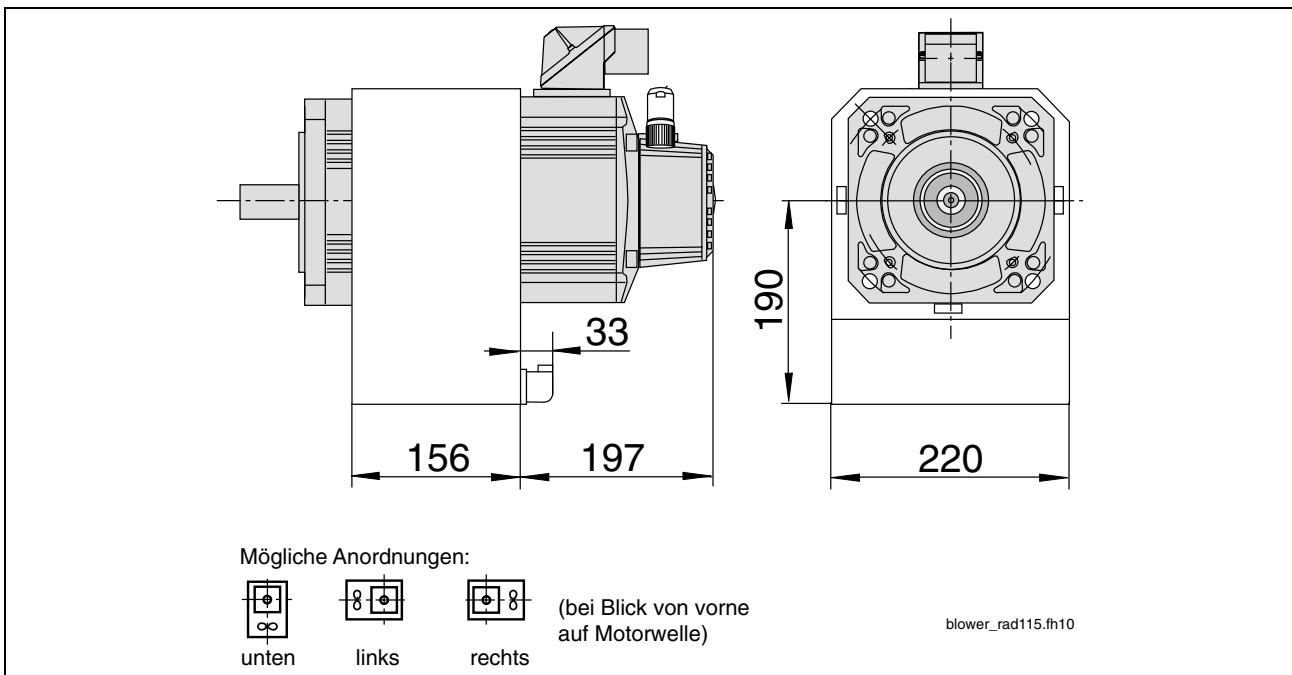

Fig. 12-20: Dimensional details about MHD115 with radial blower

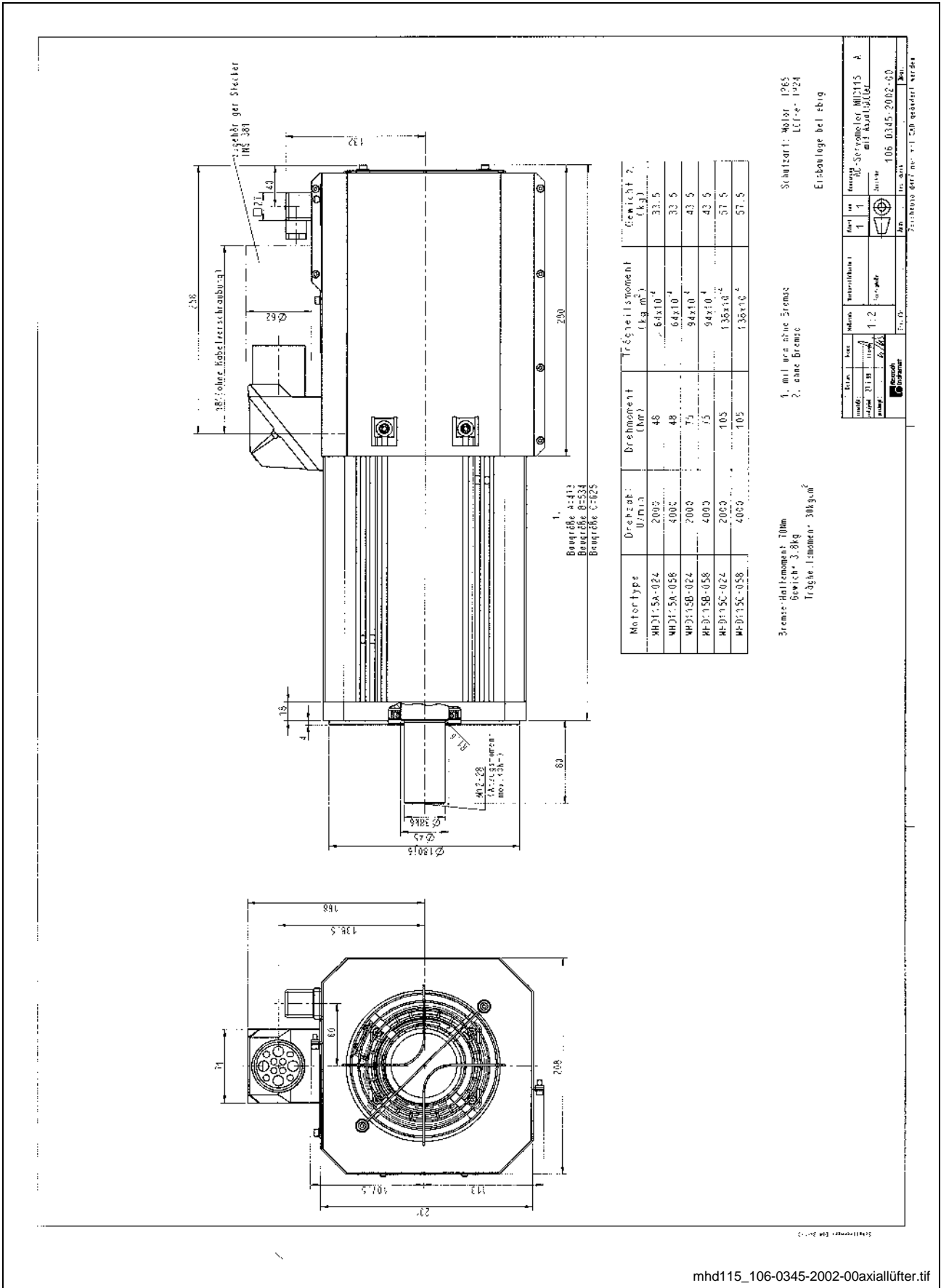

Fig. 12-21: Dimensional details about MHD115 with axial blower

13 MHD131

13.1 Technical data

Description	Symbol	Unit	MHD131B-024			
Type of cooling			Natural	Natural	Surface	Liquid
Motor overtemperature			60K	100 K	60 K/100	60 K/100
Electric parameters						
Characteristic motor speed	n_K	min^{-1}	2000			
Continuous torque at standstill	M_{dN}	Nm	85.0		127.5	
Continuous current at standstill	I_{dN}	A	51.4		77.1	
Peak current	I_{max}	A	231			
Torque constant at 20 °C ¹⁾	K_m	Nm/A	1.82			
Voltage constant at 20 °C	$K_{E(eff)}$	V/1000min ⁻¹	158.2			
Winding resistance at 20 °C	R12	Ω	0.17			
Winding inductivity	L12	mH	5.2			
Number of pole pairs	p		4			
Rated data ²⁾						
Rated speed	n_N	min^{-1}	1500		1500	
Rated torque	M_N	Nm	33.6		96.8	
Rated current	I_N	A	14.4	in	41.4	not
Rated performance	P_N	kW	6.0	Preparation	17.5	available
Rated voltage	U_N	V	244		279	
Rated frequency	f_N	Hz	100		100	
Mechanical parameters						
Moment of inertia of the rotor	J_M	kgm^2	232×10^{-4}			
Theoretical maximum torque	M_{max}	Nm	220			
Minimum strand cross-section ⁴⁾	S	mm^2	6.0		25.0	
time constant	T_{th}	min	100		45	
Maximum speed	n_{max}	min^{-1}	3000			
Motor mass ^{3) 5)}	m	kg	84			
Perm. stor. a. transport temperature	T_L	°C	-20 to +80			
Permissible ambient temperature ⁶⁾	T_{um}	°C	0 to 40			
Maximum setup height ⁶⁾	h	m	1000 above MSL			
Degree of protection ⁷⁾			IP65			
Insulation class (according to DIN VDE 0530 Part 1)			F			
Housing varnish			Prime coat black in a/w RAL 9005			
¹⁾ K_m is to be used for calculations with crest values (I_{dN} , I_{max}). For calculations with root-mean-square values (rated data), the torque constant K_m must be multiplied by a factor of $\sqrt{2}$. ²⁾ Values determined according to EN 60034-1. Current and voltage specified as root-mean-square values. ³⁾ Without holding brake. ⁴⁾ Applicable to Bosch Rexroth cables. Rated according to VDE0298-4 (1992) and installation type B2 according to EN 60204-1 (1993) at an ambient temperature of 40 °C. ⁵⁾ Without blower unit. ⁶⁾ If the limits specified are exceeded, the performance data must be reduced if necessary. For reduction factors, refer to the chapter entitled "Environmental Conditions". ⁷⁾ Provided the power and encoder cables are mounted properly.						

Fig. 13-1: Technical data of MHD131B-024

Description	Symbol	Unit	MHD131D-024			
Type of cooling			Natural	Natural	Surface	Liquid
Motor overtemperature			60K	100 K	60 K/100	60 K/100
Electric parameters						
Characteristic motor speed	n_K	min^{-1}	2000			
Continuous torque at standstill	M_{dN}	Nm	160		240	
Continuous current at standstill	I_{dN}	A	88.4		132.6	
Peak current	I_{max}	A	398			
Torque constant at 20 °C ¹⁾	K_m	Nm/A	1.99			
Voltage constant at 20 °C	$K_{E(\text{eff})}$	V/1000 min^{-1}	173			
Winding resistance at 20 °C	R12	Ω	0.08			
Winding inductivity	L12	mH	2.5			
Number of pole pairs	p		4			
Rated data ²⁾						
Rated speed	n_N	min^{-1}	1000		1500	
Rated torque	M_N	Nm	59.3		148	
Rated current	I_N	A	23.2	in	57.8	not
Rated performance	P_N	kW	7.0	Preparation	26.5	available
Rated voltage	U_N	V	177		279	
Rated frequency	f_N	Hz	67		100	
Mechanical parameters						
Moment of inertia of the rotor	J_M	kgm^2	382×10^{-4}			
Theoretical maximum torque	M_{max}	Nm	448			
Minimum strand cross-section ⁴⁾	S	mm^2	16.0		25.0	
time constant	T_{th}	min	140		60	
Maximum speed	n_{max}	min^{-1}	3000			
Motor mass ^{3) 5)}	m	kg	113			
Perm. stor. a. transport temperature	T_L	°C	-20 to +80			
Permissible ambient temperature ⁶⁾	T_{um}	°C	0 to 40			
Maximum setup height ⁶⁾	h	m	1000 above MSL			
Degree of protection ⁷⁾			IP65			
Insulation class (according to DIN VDE 0530 Part 1)			F			
Housing varnish			Prime coat black in a/w RAL 9005			
¹⁾ K_m is to be used for calculations with crest values (I_{dN} , I_{max}). For calculations with root-mean-square values (rated data), the torque constant K_m must be multiplied by a factor of $\sqrt{2}$. ²⁾ Values determined according to EN 60034-1. Current and voltage specified as root-mean-square values. ³⁾ Without holding brake. ⁴⁾ Applicable to Bosch Rexroth cables. Rated according to VDE0298-4 (1992) and installation type B2 according to EN 60204-1 (1993) at an ambient temperature of 40 °C. ⁵⁾ Without blower unit. ⁶⁾ If the limits specified are exceeded, the performance data must be reduced if necessary. For reduction factors, refer to the chapter entitled "Environmental Conditions". ⁷⁾ Provided the power and encoder cables are mounted properly.						

Fig. 13-2: Technical data of MHD131D-024

Holding brake

Description	Symbol	Unit	Holding brake 1	Holding brake 2
Motor type			MHD131B, -D	MHD131D
Holding torque	M_4	Nm	100	240
Rated voltage	U_N	V	24 ±10%	24 ±10%
Rated current	I_N	A	2.0	1.87
Moment of inertia	J_B	Kgm ²	0.0053	0.0188
Connection time	t_1	ms	12	30
Disconnection time	t_2	ms	190	300
Mass	m_B	kg	5.4	19.0

Fig. 13-3: Technical data of MHD131 holding brake (optional)

13.2 Type Code – Ordering Name

Abbrev. Column	1	2	3	4	5	6	7	8	9	0	1	2	3	4	5	6	7	8	9	0	1	2	3	4	5	6	7	8	9	0	1	2	3	4	5	6	7	8	9	0				
Example:	M	H	D	1	3	1	B	-	0	2	4	-	N	G	1	-	B	N																										

- 1. Product**
 - 1.1 MHD..... = MHD

- 2. Motor size**
 - 2.1 131..... = 131

- 3. Motor length**
 - 3.1 Lengths = B, D

- 4. Windings code**
 - 4.1 MHD131B = 012, 024
 - 4.2 MHD131D = 012, 024

- 5. Motor encoder**
 - 5.1 digital servo feedback = N
 - 5.2 digital servo feedback with integrated multiturn absolute encoder = P

- 6. Driven shaft**
 - 6.1 plain shaft (with shaft sealing ring) = G
 - 6.2 Shaft with key per DIN 6885-1 (with shaft sealing ring) = P

- 7. Holding brake ①**
 - 7.1 without holding brake = 0
 - 7.2 with holding brake 100 Nm = 1
 - 7.3 with holding brake 240 Nm = 2

- 8. Output direction of power connection ②**
 - 8.1 Connector to side A = A
 - 8.2 Connector to side B = B
 - 8.3 Connector to the left = L
 - 8.4 Connector to the right = R

- 9. Housing design**
 - 9.1 for natural convection or surface cooling = N

- 10. Standard reference**

Standard	Title	Edition
DIN 6885-1	Drive Type with Fastenings without Taper Action; Parallel Keys, Keyways, Deep Pattern	1968-08

Note:

- ① Holding brake "2" is only available with motor length "D"
- ② Looking from front onto driven shaft

t_mhd131_M06en.fh10

Fig. 13-4: Type code MHD131

13.3 Speed-Torque Curves

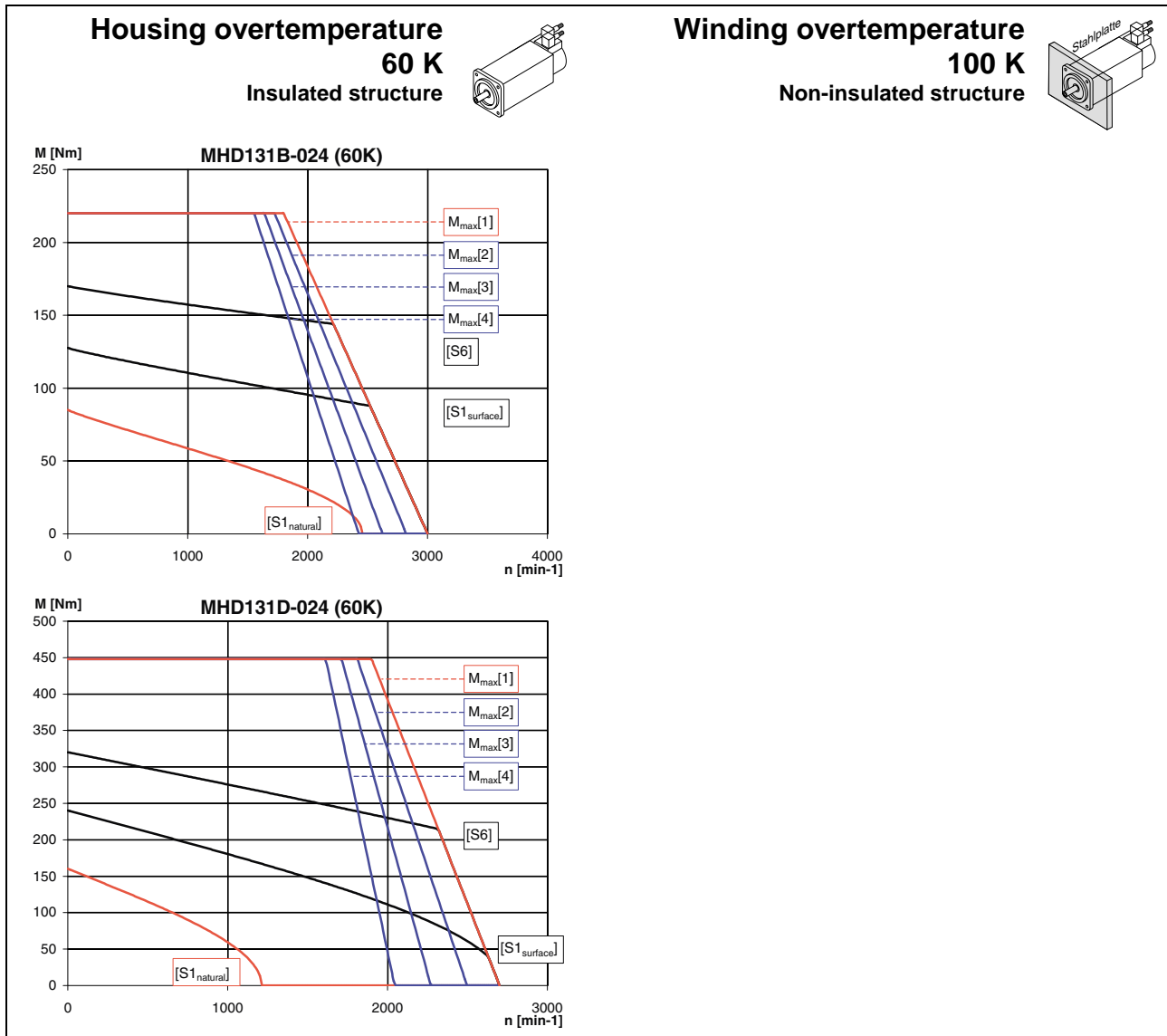

- [S1_{natural}]: M_{dN} Natural conv. (S1 continuous operation)
- [S1_{surface}]: M_{dN} Surface cooling (S1 continuous operation)
- [S6]: M_{KB} (S6 intermittent operation)
- $M_{max}[1]$: HDS to HVR
- $M_{max}[2]$: HDS to HVE or DKCxx.3 with a power connection of 3 x AC 480 V
- $M_{max}[3]$: HDS to HVE or DKCxx.3 with a power connection of 3 x AC 440 V
- $M_{max}[4]$: HDS to HVE or DKCxx.3 with a power connection of 3 x AC 400 V

Fig. 13-5: Characteristic curves

13.4 Shaft loads

Permissible maximum radial force $F_{\text{radial_max}}$ and permissible radial force F_{radial}

For explanations refer to Chapter 16.

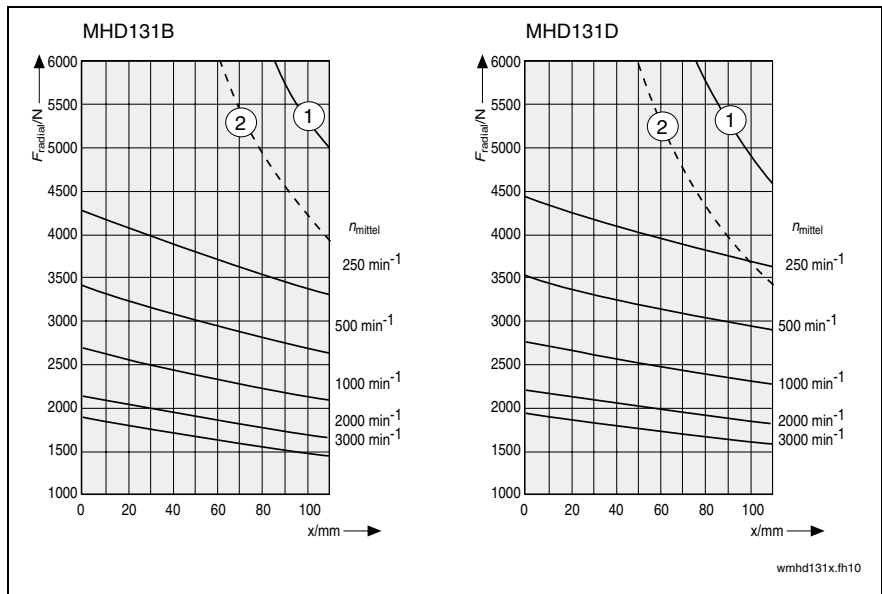

- (1): $F_{\text{radial_max}}$ (plain shaft)
- (2): $F_{\text{radial_max}}$ (shaft with keyway)

Fig. 13-6: MHD131: Permissible maximum radial force $F_{\text{radial_max}}$ and permissible radial force F_{radial}

Permissible axial force F_{axial}

$$F_{\text{axial}} = x \cdot F_{\text{radial}}$$

- x: 0.46 for MHD131B,
0.44 for MHD131D,
- F_{axial} : permissible axial force in N
- F_{radial} : permissible radial force in N

Fig. 13-7: MHD131: permissible axial force F_{axial}

13.5 Dimensional Details

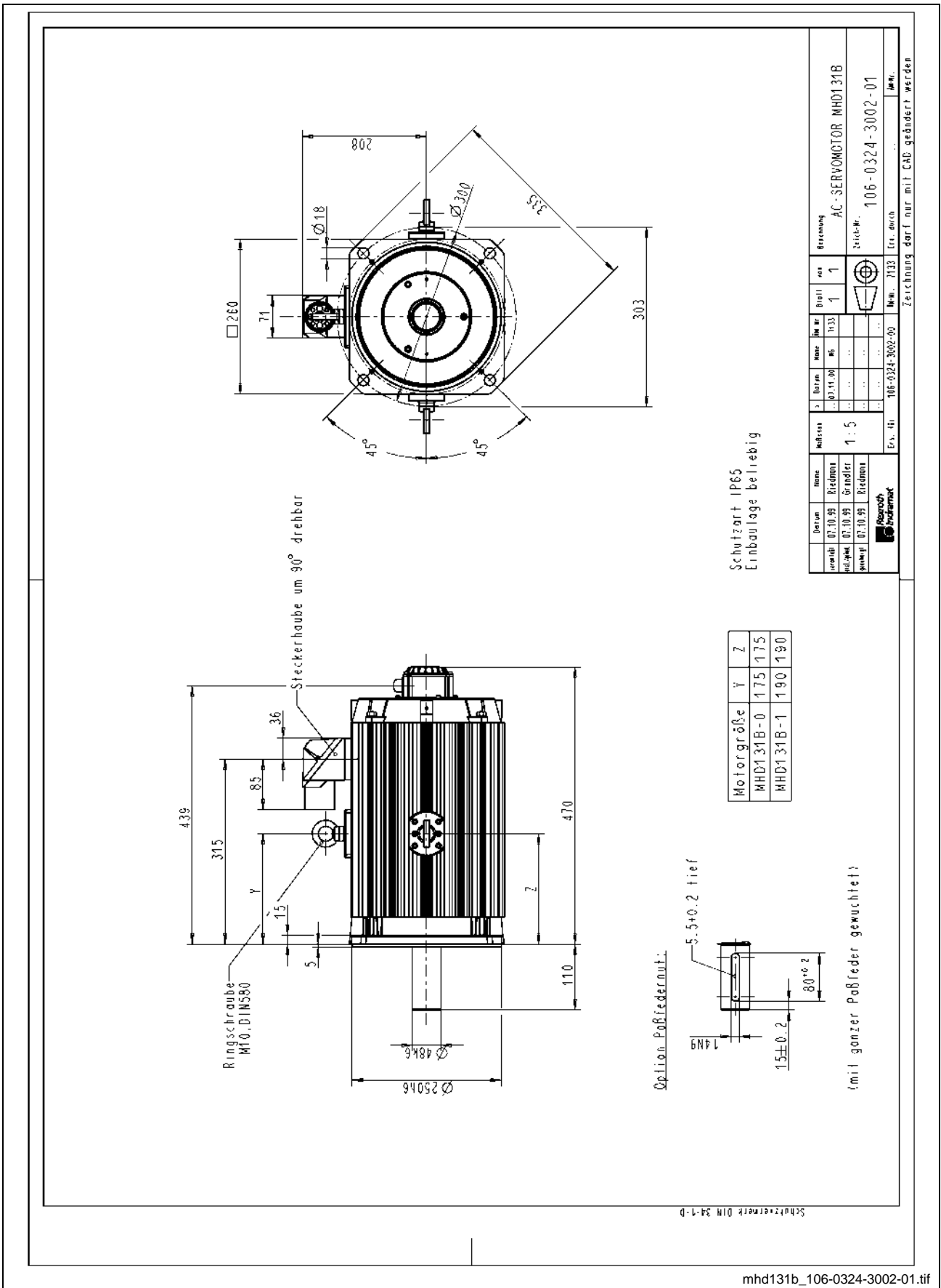

mhd131b_106-0324-3002-01.tif

Fig. 13-8: Dimensional details of MHD131B

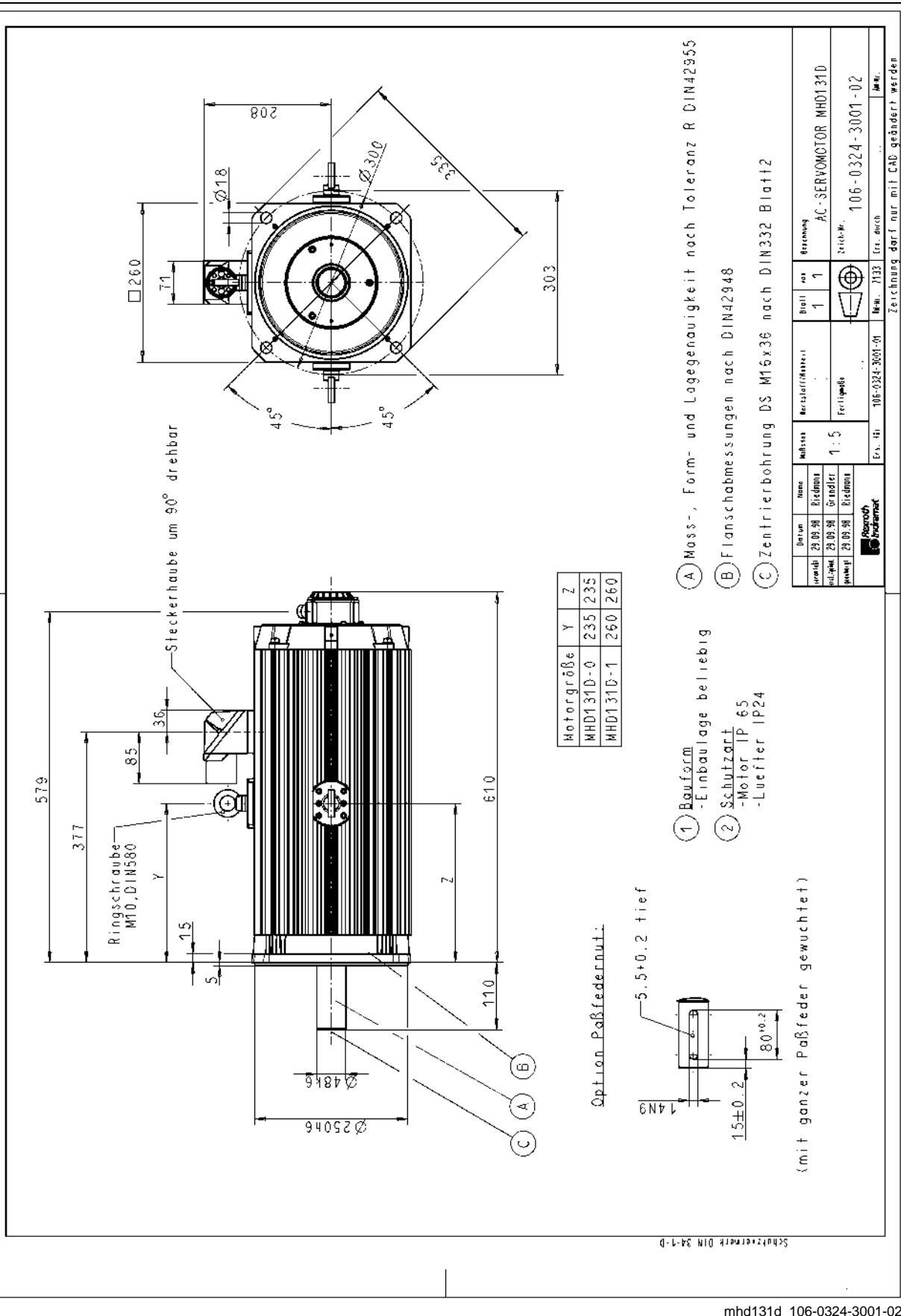

mhd131d_106-0324-3001-02.tif

Fig. 13-9: Dimensional details of MHD131D

Shaft end

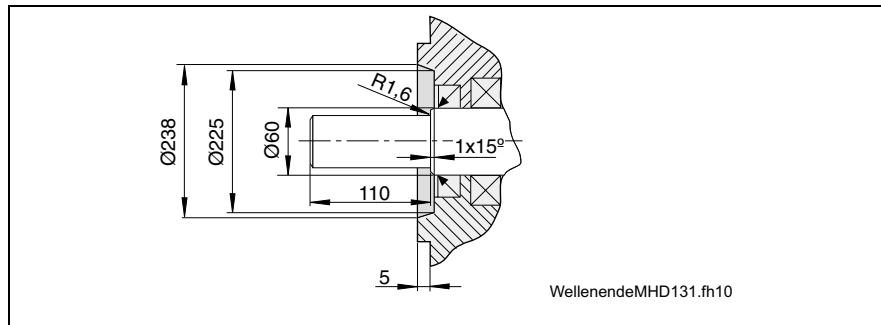

Fig. 13-10: MHD131 shaft end

- Shaft end cylindrical according to DIN 748, Part 3, ed. 07.75.
- DS M16 centering hole according to DIN 332, Part 2, ed. 05.83, max. tightening torque for screw 107 Nm.
- Vibration severity grade R according to DIN VDE 0530, Part 14, ed. 02.93.

- Motor design**
- Motor design B5 according to EN 60034-7 / 1993 for all installation positions.

- Flange**
- Flange according to DIN 42948, ed. 11.65.
 - Positional accuracy with regard to true running, axial running and coaxiality to the shaft according to DIN 42955 Tolerance Class R, ed. 12.81

- Output shaft**
- Plain shaft (preferred type)
- or
- Shaft with keyway according to DIN 6885, Sheet 1, ed. 08.68.

Note: Caution! Balanced with **complete** featherkey!

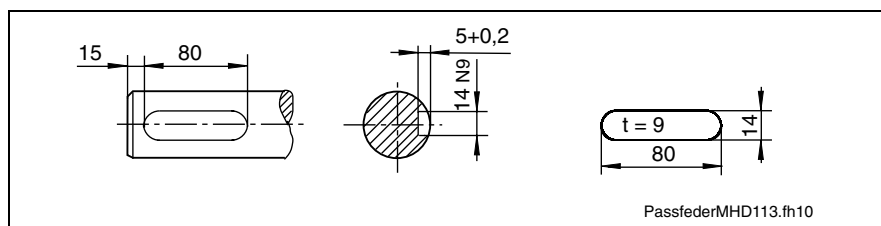

Fig. 13-11: Output shaft with keyway of MHD131

Note: Pertinent featherkey: DIN 6685-A 14 x 9 x 80; not included in the scope of delivery of the motor.

- Options** For options refer to the chapter entitled "Type Code – Ordering Name".

13.6 Blower Units

MHD motors can also be delivered with optional blower units. Please refer to the "Surface" column of the data sheets for performance data of surface-cooled motors. The mechanical dimensions of the blower units are represented in the dimension drawings. The possibilities of combining motor and blower unit and the technical data of the blowers are represented in the table below.

Motor	Ordering name of blower unit			
	LEMH-AB131B3H1		LEM-AB131D3H1 ¹⁾	
MHD131B	x	x	---	---
MHD131D	x	x	x	x
--- Blower installation <u>not</u> possible; x Blower installation possible				

Technical data of blower unit					LEM-AB131D3H1 ¹⁾	
Description	Symbol	Unit				
Type of cooling			axial		axial	
Air flow			B ⇒A blowing		B ⇒A blowing	
Rated voltage	U _n	V	3x 400 V, ±15% 50 Hz	3x 460 V, ±10% 60 Hz	3x 400 V, ±15% 50 Hz	3x 460 V, ±10% 60 Hz
Power consumption	P _n	W	82	70	95	130
Rated current	I	A	0.21	0.15	0.24	0.28
Mean air volume	V	m ³ /h	295	295	1000	1000
Blower unit mass	m _L	kg	8.6	8.6		
Noise level		dB(A)	75	75		

1): latest delivery 8-2002

Fig. 13-12: Technical data of MHD131 blower units (optional)

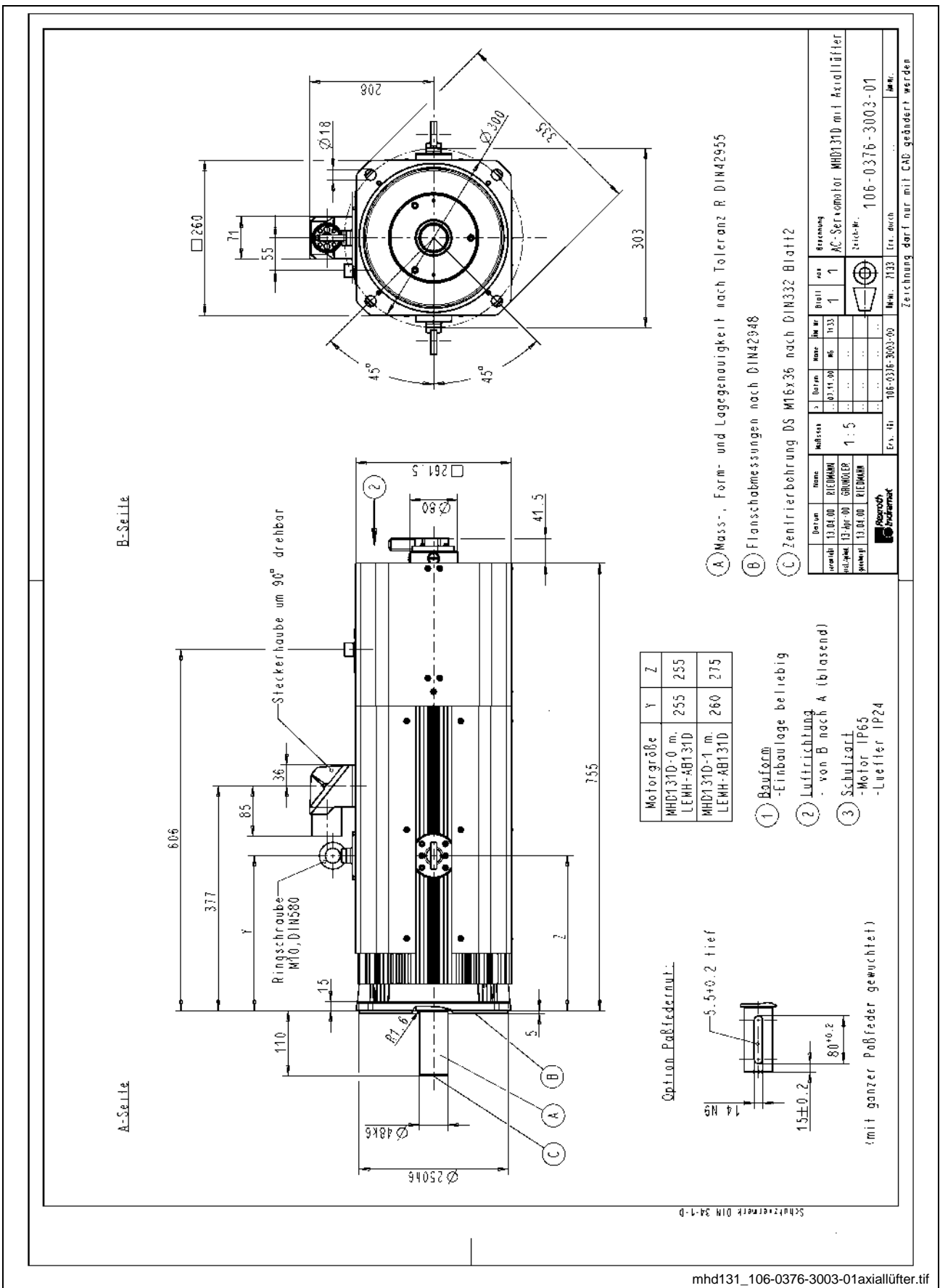

Fig. 13-13 Dimensions of MHD131 with axial blower LEM-AB131D3H1 (latest delivery 08-2002).

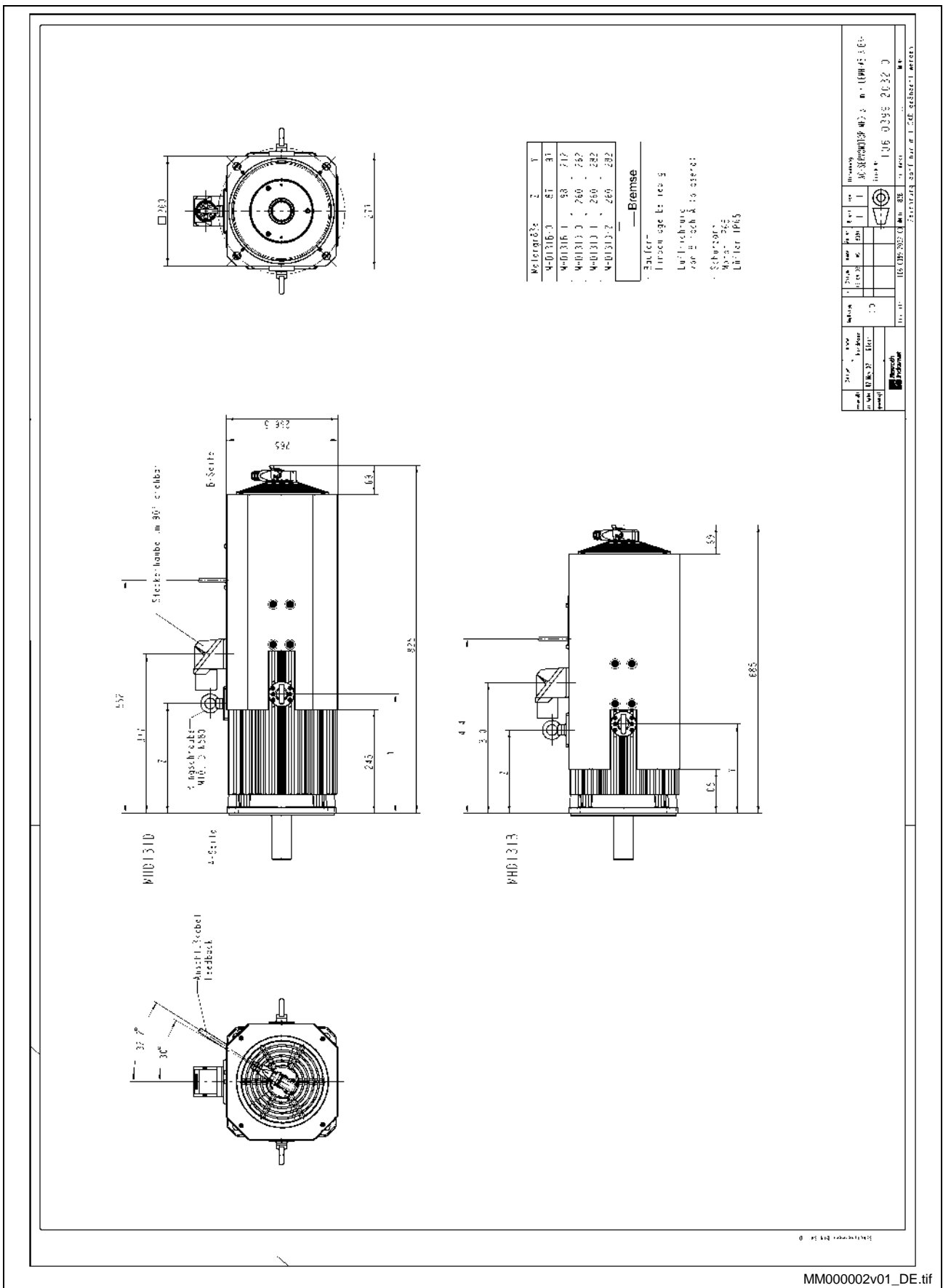

Fig. 13-14: Dimensions of MHD131 with axial blower LEMH-AB131B3H1

14 Accessories

Sealing Air Connection Accessories

Optional Sealing Air Connector Sealing air connectors are available for MHD motors. They are attached to the motor by simply replacing the motor flange socket cover. The overpressure inside the motor prevents penetrating oils, aggressive coolants, and the like from entering.

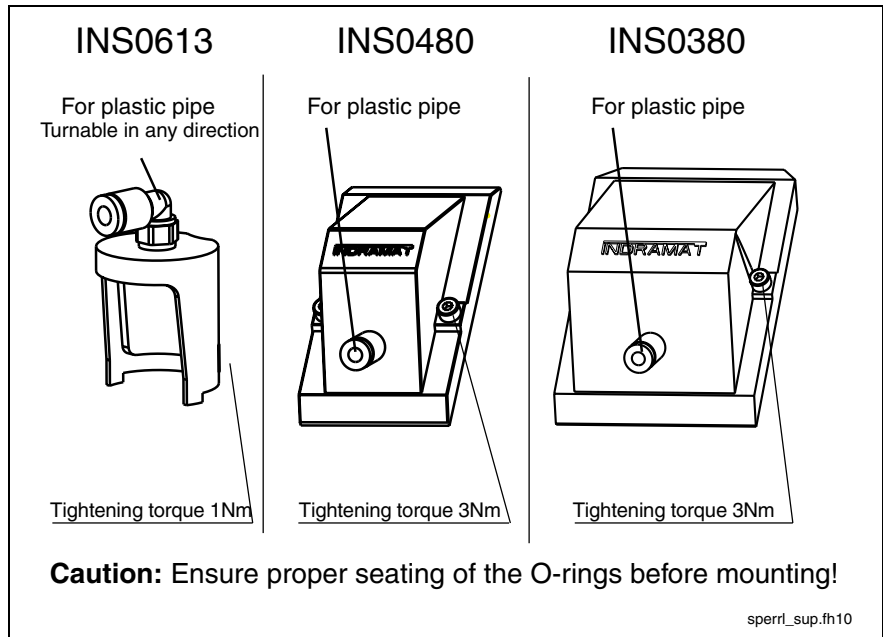

Fig. 14-1: MHD air-pressure connector kit

Note: When mounting the motor flange socket covers with sealing air connector, ensure that the O-rings are properly seated. The degree of protection required is ensured only with correct assembly.

Ordering name of accessory sets

The motor flange socket covers available with sealing air connector are listed in the table below.

Motor flange socket (type)	Description
INS0480 (power connector)	SUP-M01-MHD
INS0380 (power connector)	SUP-M02-MHD
INS0613 (feedback connector)	SUP-M03-MHD

Fig. 14-2: Sealing air connector accessory

Transmission

GTS, GTP, GTM Planetary Gearings

Planetary gearings for the

- GTS and
- GTP
- GTM

series are suitable for being attached to MHD motors and can be obtained from Bosch Rexroth.

The planetary gearings are characterized by the following features:

- | | |
|-------------------------------------|--|
| High operational reliability | <ul style="list-style-type: none"> • Low-maintenance operation owing to lifetime lubrication • Use under adverse environmental conditions is possible (owing to the completely closed design in IP 65 degree of protection) |
| High performance data | <ul style="list-style-type: none"> • Low-play gear teeth with minimum reverse play owing to ground gear pairs • High torsional strength owing to load distribution to three planetary wheels • High efficiency owing to planetary wheel principle • High dynamics owing to low masses of inertia • Low weight owing to compact design |
| Easy attachment to machine | <ul style="list-style-type: none"> • Direct overhung mounting of pinions and belt pulleys, owing to the bearing being designed for high permissible radial loads • Flange design permitting attachment according to design B5 (DIN 42959, Part 1, ed. 08.77) with hole in the flange |

The output shaft can be mounted in two different ways:

- friction-locked shaft-hub connection by means of a plain shaft, or
- friction-locked shaft-hub connection by means of an output shaft with keyway.

Note: Refer to the documentation DOK-GEAR**-GTx*****-PRxx-EN-P for a detailed description of the GTP planetary gearings.

x = M für GTM
x = P für GTP
x = S für GTS

Worm Gears 058

- Field of application** Worm gears of the
- 58...
- series are suitable for being attached to MHD motors and are characterized by the following features:
- High operational reliability**
- Low-maintenance operation owing to oil lubrication
 - Use under adverse environmental conditions is possible (owing to the completely closed design in IP 65 degree of protection)
- High performance data**
- Low-play gear teeth readjustable during operation, owing to ground gear pairs
 - Low noise development owing to worm gear principle
 - High dynamics owing to low masses of inertia
 - Low weight owing to housing components made of aluminum
- Easy attachment to machine**
- Direct overhung mounting of pinions and belt pulleys, owing to the bearing being designed for high permissible radial loads
 - The output elements can be mounted in two different ways:
 - friction-locked shaft-hub connection by means of a plain output hollow shaft, or
 - friction-locked shaft-hub connection by means of an output hollow shaft with keyway
 - The housing design of the gear permits attachment to the machine in very many ways.

Note: Refer to the documentation DOK-GEAR**--58*WORMGEAR-PRJ1-EN-P for a detailed description of the 58... worm gears.

Notes

15 Connection System

15.1 Overview of Connections

The electric connections of Bosch Rexroth drives are standardized. The MHD AC motors are provided with

- a power connector, incl. connection for temperature sensor and holding brake,
- an encoder connection (feedback connector).

Both connectors are designed as separate plug connections.

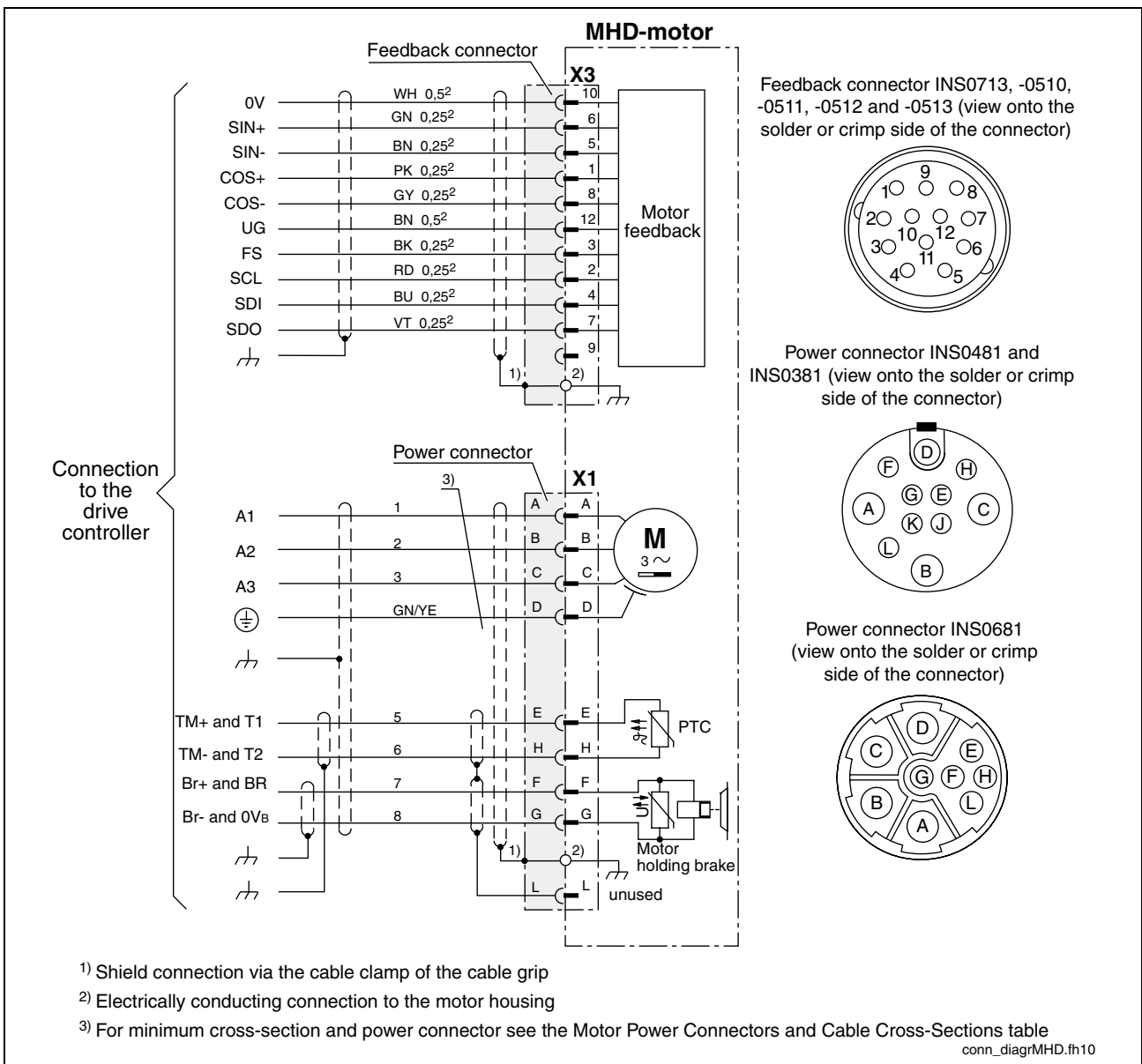

Fig. 15-1: MHD Connection diagram

15.2 Power Connector

MHD motors are supplied with power via flange sockets with screwed connection (INS0680) or bayonet catch (INS0480 and INS0380).

Plugs and cables are not included in the scope of delivery of the motors and must be ordered as separate items.

Overview

Motor	Winding	Flange socket	Connector
MHD041A	144	INS0680	INS0681
MHD041B	144		
MHD071A	061		
MHD071B	035, -061		
MHD090B	035, -047, -058		
MHD093A	024, -035, -058		
MHD093B	024, -035, -058		
MHD093C	024, -035, -058	INS0480	INS0481
MHD095A	024, -035, -058		
MHD095B	024, -035, -058		
MHD095C	024, -035, -058		
MHD112A	024, -035, -058		
MHD112B	024, -035, -048, -058		
MHD112C	024, -035		
MHD112D	058	INS0380	INS0381
MHD112D	012, -027	INS0480	INS0481
MHD115A	024, -035, -058	INS0380	INS0381
MHD115B	024, -035, -058		
MHD115C	024, -035, -058		
MHD131B	024		
MHD131D	024		

Fig. 15-2: Overview of MHD power connectors

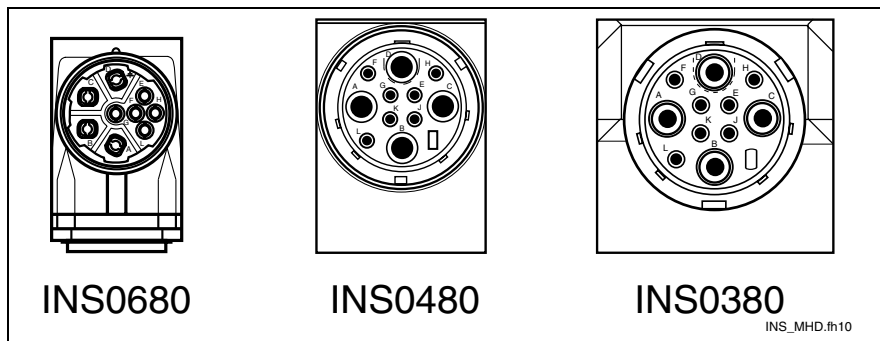

Fig. 15-3: MHD flange sockets

Flange socket	INS0680	INS0480	INS0380	Description
Power supply contacts	A,B,C	A,B,C	A,B,C	U1, V1, W1
PE contact	D	D	D	
Temp. sensor contacts	E,H	E,H	E,H	T1, T2
Brake contact	F,G	F,G	F,G	Br+, Br-
Unused contacts	L	J,K,L	J,K,L	

Fig. 15-4: Pin assignment of flange socket for the MHD power connector

15.3 Encoder connection

Flange socket

Please refer to the overview of connectors for the assignment of the encoder signals and the pin assignment of the flange socket.

Flange socket	INS0514 INS0524 INS0613	Description
Contacts	1, 2, 3, 4, 5, 6, 7, 8, 10	See overview of connectors
Unused contacts	9, 11	

Fig. 15-5: Pin assignment of flange socket for the MHD encoder connection

15.4 Blower connection

MHD motors can be supplied optionally with axial or radial blowers. The various connection possibilities are described in the table below.

Please refer to the technical data for the blower units available.

MHD	Power connection	Blowers	Direction	Blower connection	Type of connection	Supply voltage
071 090	Flange socket	Radial	B > A (blowing)	Flange socket + plug	(1)	230 V AC, 115 V AC ±10%, 50...60 Hz
093 095 112 115	Flange socket	axial	B > A (blowing)	Flange socket + plug	(1)	
		Radial	B > A (blowing)	Flange socket + plug	(1)	
131	Flange socket	axial	B > A (blowing)	Flange socket + plug	(2), (3)	3 x 400 V AC, ±15%, 50...60 Hz

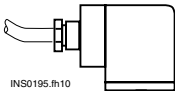

INS0195.ft10

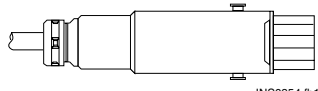

INS0354.ft10

The indices (1) and (2) are used in this chapter to explain the types of connection. Please observe the examples below.

Fig. 15-6: Table of MHD blower connections

Note: To establish the connection, the blower plug must be opened and closed.

- The electric connection may be established by qualified technical personnel only. Please observe the safety instructions.
- The housing tightness may not be reduced.

Design (1)

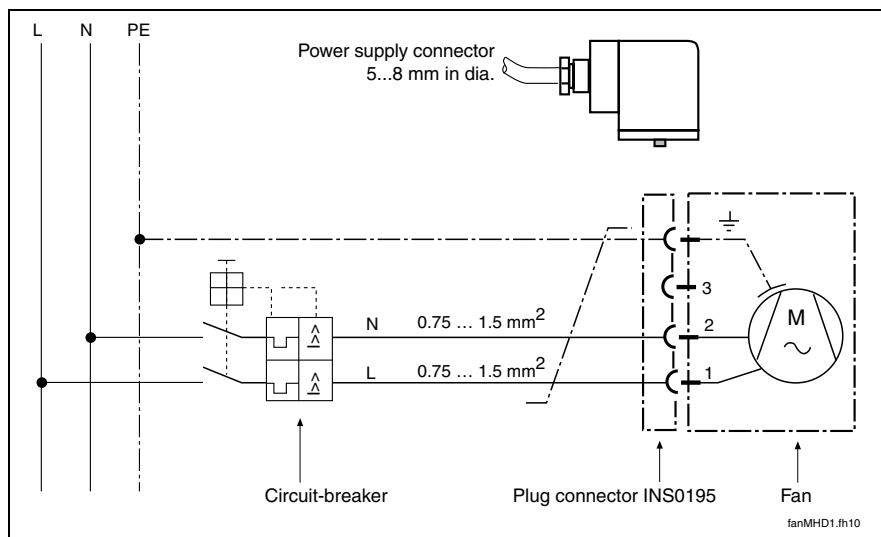
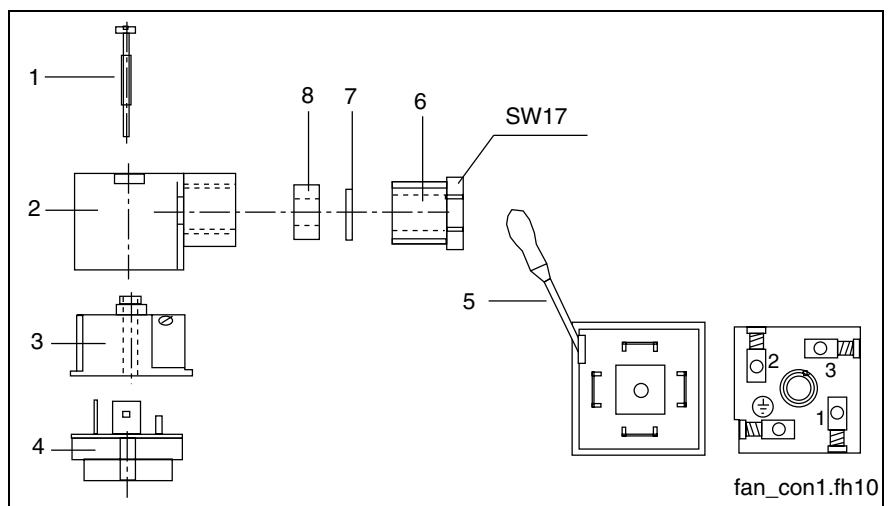

Fig. 15-7: Blower connector type (1)

Connecting and mounting the blower plug

Electric connection

A three-core cable with a connection cross-section of at least 0.75 mm² must be used as connection cable.



- (1): Housing screw
- (2): Plug housing
- (3): Plug insert
- (4): Flange socket
- (5): Screwdriver
- (6): Heavy-gauge conduit thread
- (7): Washer
- (8): Seal

Fig. 15-8: Blower connector type (2)

Proceed as follows to mount the connection cable to the blower plug:

1. Loosen the heavy-gauge conduit thread (6) (size 17).
2. Turn the cylinder screw (1) out of the socket (4) using the screwdriver (5).
3. Pull off the plug housing (2) including the plug insert (3) from the flange socket (4).
4. Pull out the cylinder screw (1).
5. Remove the plug insert (3) from the plug housing (2) (see Fig. 15-8).

6. Push the heavy-gauge conduit thread (6), the washer (7), the seal (8), and the plug housing (2) onto the connection cable (3 x 0.75 mm²).
7. Strip the outer sheath of the cable for approx. 20 mm, litz wires for 10 mm, and connect it to the plug insert (3) as illustrated above.
8. Push the plug insert (3) into the plug housing (2); fit the cylinder screw (1); screw the plug to the socket (4).
9. Tighten the heavy-gauge conduit thread (6), while ensuring strain relief.

Design (2) -3-pin

Note: Technical changing of the ventilator unit LEMH-AB131D3H1. Latest delivery of the type (2) 08-2002. Replaced by the ventilator unit LEMH-AB131B3H1 (for description see type (3)).

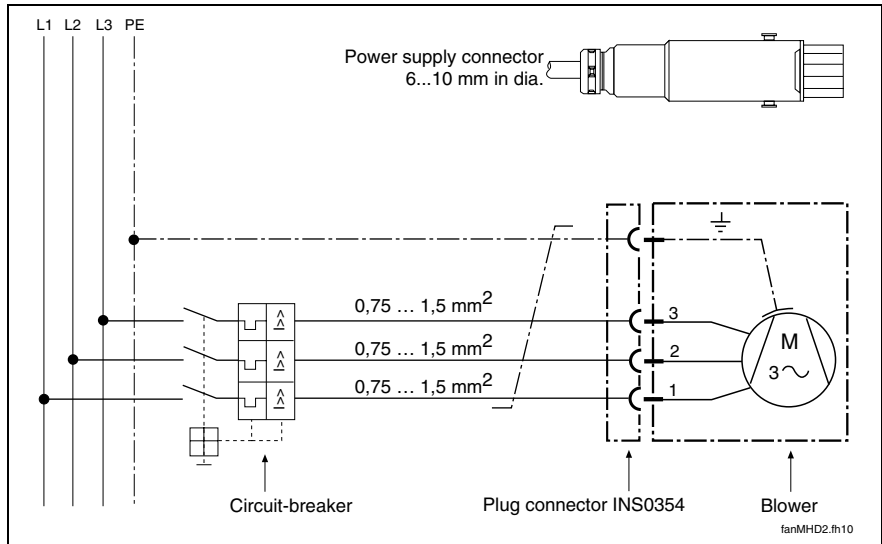
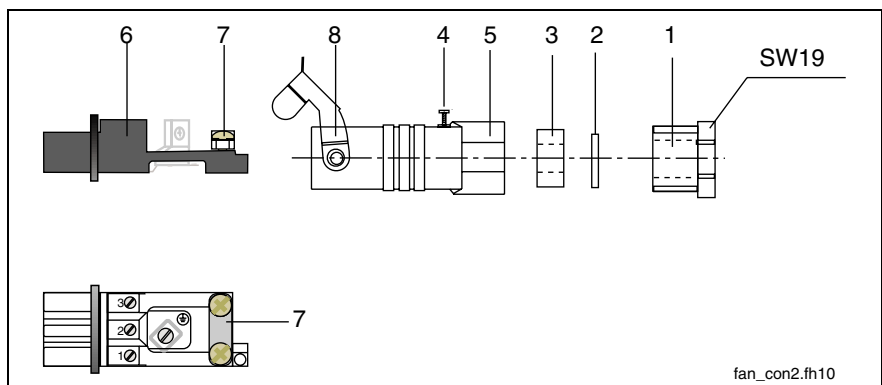

Fig. 15-9: Blower connector type (2)

Connecting and mounting the blower plug

Electric connection A 4-core cable with a minimum cross-section of 0.75mm² must be used as connection cable.

Proceed as follows to mount the connection cable to the blower plug:



- (1): Heavy-gauge conduit thread
- (2): Washer
- (3): Seal
- (4): Housing screw
- (5): Housing
- (6): Plug insert
- (7): Strain relief clamp
- (8): Safety bracket

Fig. 15-10: Blower connector type (2)

- Mounting instructions**
1. Unscrew the heavy-gauge conduit thread (1).
 2. Remove the washer (2) and the seal (3).
 3. Loosen the housing screw (4).
 4. Remove the plug insert (6) from the housing (5).
 5. Adjust the seal to the outer diameter of the connection cable.
 6. Push the parts (1), (2), (3), and (5) over the connection cable.
 7. Unsheath the connection cable and attach the connector sleeves to the litz wires.
 8. Connect the litz wires as shown in the connection diagram.
 9. Clamp the outer sheath of the cable under the strain relief clamp (7).
 10. Push the plug insert (6) into the housing (5) and fix it using the housing screw (4).
 11. Screw the seal (3), the washer (2), and the heavy-gauge conduit thread (1) into the housing (5).
 12. After having fitted the prepared plug, snap the safety bracket (8) into place.

Design (3) -4-pin

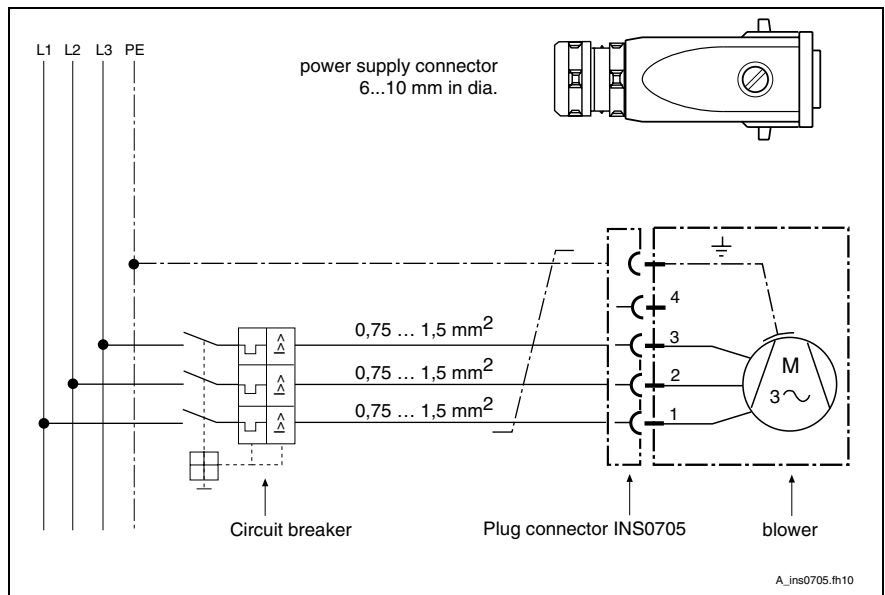

Fig. 15-11: Blower connection design (3)

Connecting and mounting the blower plug

Electric connection A 4-core cable with a minimum cross-section of 0.75mm² must be used as connection cable.

15.5 Connection Cable

Bosch Rexroth delivers ready-made power and encoder cable sets. The following documentation contains:

- an overview of the cable types available.
- technical data of the various cables,
- general installation regulations for Bosch Rexroth cables.

Ordering name DOK-CONNEC-CABLE*STAND-AUxx-EN-P
Material number: 00280894

or

Note: Refer to the appendix to this documentation for a selection overview of motor power cables.

16 Notes Application

16.1 Conditions for use

Setup Height and Ambient Temperature

Nominal data The performance data specified for the motors apply in the following conditions:

Ambient temperature of 0 °C up to +45 °C

Setup heights of 0 m up to 1000 m above MSL.

Exceeding the nominal data Derating curves If you intend to use motors above these ranges, you must take the "utilization factors" into consideration. This reduces the performance data.

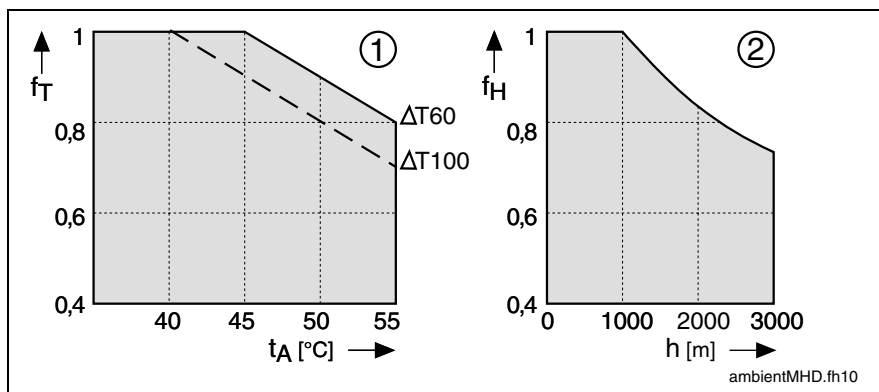

(1): Utilization depending on the ambient temperature

(2): Utilization depending on the setup elevation

f_T : Temperature utilization factor

t_A : Ambient temperature in degrees Celsius

$\Delta T60 / \Delta T100$: Mode of operation

f_H : Height utilization factor

h : Setup elevation in meters

Fig. 16-1: MHD derating (utilization factors)

If **either** the ambient temperature **or** the setup height exceeds the nominal data:

1. Multiply the torque data specified in the selection data by the utilization factor.
2. Ensure that the reduced torque data are not exceeded by your application.

If **both** the ambient temperature **and** the setup height are exceeding the nominal data:

1. Multiply the determined utilization factors f_T and f_H by each other.
2. Multiply the value obtained by the motor torque data specified in the selection data.
3. Ensure that the reduced torque data are not exceeded by your application.

Vibration and shock loading

MHD motors can carry loads, such as are typically occurring in case of presses, punches, or press inlets, only if they are attached in a shock-absorbed or shock-decoupled way. The construction of such attachments must be checked in isolated cases.

According to IEC 721-3-3 ed. 1987 and EN 60721-3-3 ed. 06/1994, MHD motors, if used stationary and weather-resistant, may be operated under the following conditions:

Longitudinal motor axis: according to Class 3M1

Transverse motor axis: according to Class 3M6

Ensure that the limits specified in Fig. 16-2: Limits for sinusoidal vibrations and Fig. 16-3: Limits for shock load

for storage, transport, and operation of the MHD motors are not exceeded.

Influencing quantity	Unit	Maximum value in longitudinal axis	Maximum value in transverse axis
Amplitude of the excursion at 2 to 9 Hz	mm	0,3	7,0
Amplitude of the acceleration at 9 to 200 Hz	m/s ²	1	20

Fig. 16-2: Limits for sinusoidal vibrations

Influencing quantity	Unit	Maximum value in longitudinal axis	Maximum value in transverse axis
Total shock-response spectrum (according to IEC721-1, :1990; Table 1, Section 6)		Type L	Type II
Peak acceleration	m/s ²	40	250
Duration	ms	22	6

Fig. 16-3: Limits for shock load

Note: Motors with attached blowers are **not suitable** for applications subjected to shock loads, such as are occurring in case of

- punches,
- presses, or
- loading portals.

In such cases, motors without surface-cooling and a higher torque must be used.

16.2 Protection class

The type of protection is defined by the identification symbol IP (International Protection) and two code numbers specifying the degree of protection.

The **first code number** defines the degree of protection against contact and penetration of foreign particles. The **second code number** defines the degree of protection against water.

First characteristic numeral	Degree of protection
6	Protection against penetration of dust (dust-proof); complete shock protection
4	Protection against penetration of solid foreign particles, more than 1 mm in diameter
2	Protection against penetration of solid foreign particles, more than 12 mm in diameter ⇒Keep away fingers or similar objects!
Second characteristic numeral	Degree of protection
7	Protection against harmful effects if temporarily immersed in water
5	Protection against a water jet from a nozzle directed against the housing from all directions (jet water)
4	Protection against water splashing against the housing from all directions (splashwater)

Fig. 16-4: IP protection class



Tests regarding the second characteristic numeral must be performed using fresh water. If cleaning is effected using high pressure and/or solvents, coolants, or penetrating oils, it might be necessary to select a higher degree of protection.

The design of the MHD motors complies with the following degrees of protection according to DIN VDE 0470, Part 1, ed. 11/1992 (EN 60 529):

Motor range	Protection class	Remark
Motor housing, output shaft, power and encoder connectors (if mounted properly only)	Approx. IP 67	If fitted with the optional sealing air connection
Motor housing, output shaft, power and feedback connectors (if mounted properly only)	IP 65	Standard design
Blower motor	IP 44	Standard design
Surface-cooling (blower grille) and blower connection	IP 24	Standard design

Fig. 16-5: Ranges of IP degrees of protection for the motors

Option sealing air “sealing air: principle” connection

Sealing air connectors are available for MHD motors. They are attached to the motor by simply replacing the motor flange socket cover. The overpressure inside the motor prevents penetrating oils, aggressive coolants, and the like from entering.

Note: When mounting the motor flange socket covers with sealing air connector, ensure that the O-rings are properly seated. The degree of protection required is ensured only with correct assembly.

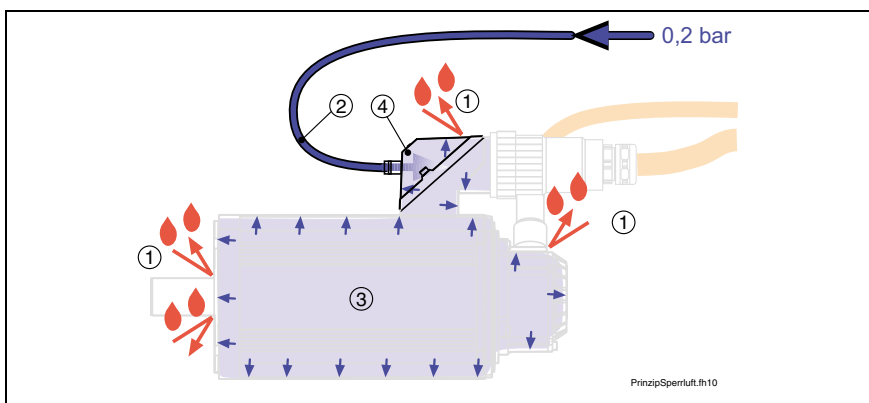

- (1): Splashing water, coolant lubricant
- (2): Compressed-air line (plastic pipe, type PA 4 x 0.75, or equivalent)
- (3): Excess pressure inside the motor
- (4): Sealing air connector accessory

Fig. 16-6: Diagram illustrating the sealing air principle

Compressed-air data: Pressure 0.1...0.2 bar, max. 0.3 bar
 Air free from dust and oil
 relative air humidity 20...30%

Tightening torques To ensure the IP 67 degree of protection, the following tightening torques of the cover screws must be kept during mounting:

Set of accessories	Tightening torque in Nm
INS0613	1,0
INS0480	3,0
INS0380	3,0

Fig. 16-7: Tightening torques

Supplier’s recommended plastic pipe

Bosch Rexroth AG
 Bartweg 13
 D-30453 Hannover
 Telefon +49 (511) 21 36-0
 Telefax +49 (511) 2 13 62 69

Plastic pipe, type PA 4 x 0.75

Dimension [mm]	Length [m]	Color	Order no.
4 x 0.75	25	blue	281 520 402 0
	50	blue	281 520 405 0

Fig. 16-8 Plastic pipe

Ordering name of accessory sets

The motor flange socket covers available with sealing air connector are listed in the table below.

Motor flange socket (type)	Description	Motor
INS0480 (power connector)	SUP-M01-MHD	MHD093 MHD095 MHD112 ¹⁾
INS0380 (power connector)	SUP-M02-MHD	MHD112C-058 MHD115 MHD131
INS0613 (feedback connector)	SUP-M03-MHD	MHD041 MHD071 MHD090
¹⁾ all MHD112 except MHD112C-058		

Fig. 16-9: Sealing air connector accessory

It must be ensured that, in each and every installation position, the motors are not subjected to ambient conditions outside of the particularly applicable degree of protection according to IEC 34-7.



Products and ranges with a low degree of protection are not suited for cleaning procedures with high pressure, vapor or water jet.

Selecting the Degree of Protection

The degree of protection must be selected depending on the installation position and the field of application. The table below supports you in selecting the degree of protection required.

Exposure	Medium	Recommended
Dry	Air	Standard IP 65
Moist	Water General coolants Oil contents (approx. 5%)	Standard IP 65
	Penetrating oils, bio-oils Coolants	Standard IP 65 + sealing air
Splash	Water General coolants Oil contents (approx. 5%)	Standard IP 65 + sealing air
	Penetrating oils, bio-oils Coolants	

Fig. 16-10: Selecting the degree of protection

16.3 Design and Installation Positions

MHD motors are available in design B05. Please refer to the table below for the types of installation permissible according to EN 60034-7:1993.

Motor design	Permissible types of installation		
	Description	Sketch	Setup
B05	IM B5		Flange attached on the drive side of the flange
	IM V1		Flange attached on the drive side of the flange; drive side pointing down
	IM V3		Flange attached on the drive side of the flange; drive side pointing up

Fig. 16-11: Mounting position



Penetration of fluids! If motors are attached according to IM V3, fluid present at the output shaft over a prolonged time may enter into and cause damage to the motors.

⇒For that reason, ensure that fluid cannot be present at the output shaft.

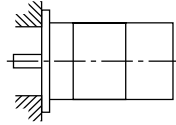
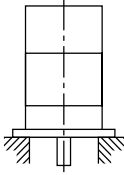
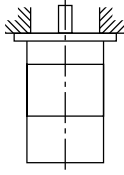
Prime Coat and Housing Varnish

State upon delivery: Prime coat black in a/w RAL 9005

Resistance: Against weather, coloring, chalking, diluted acids and diluted lyes

It is not permitted to provide the housing with additional varnish (coat thickness no more than 40 µm).

16.4 Blowers

In case of extreme loads, e.g. during continuous start-stop operation with high repeat frequencies, radial or axial blowers can be attached to the motors of the

- MHD071
- MHD090
- MHD093
- MHD095
- MHD112
- MHD115
- MHD131

motor type series.

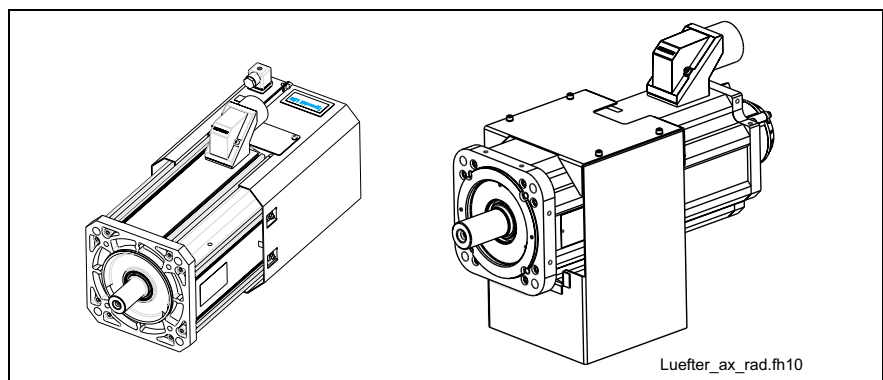

Fig. 16-12: Blower attached to MHD motors (example)

When being ordered, blower units are specified as ordering subitem. It is possible to procure blower units separately or already attached to the motors. This information must be provided upon ordering. Please refer to the chapters entitled "Technical Data" for more detailed information on ordering data.

Note: Motors with attached blower units are **not suitable** for applications subjected to shock loads, such as are occurring in case of

- punches,
- presses, or
- loading portals.

In such cases, motors without surface-cooling and a higher torque must be used.

Notes on ordering:**Motor with attached blower unit**

In order to procure a motor with attached surface-cooling, the type name of the blower unit must be specified as an ordering subitem of the MDH motor with the blower arrangement desired.

Ordering item	Ordering name
1	1 ea Digital AC motor MHD071B-035-NG0-BN
1.1	1 ea Blower unit LEMD-RB071B2XX attached to Item 1, blower arranged to the left

Fig. 16-13: Ordering data for an MHD motor with attached blower unit

Motor with separate blower unit

If it is specified as an independent ordering item, the blower unit is delivered separately from the motor (i.e. not attached to the latter).

Ordering item	Ordering name
1	1 ea Digital AC motor MHD071B-035-NG0-BN
2	1 ea Blower unit LEMD-RB071B2XX

Fig. 16-14: Ordering data for an MHD motor with separate blower unit

16.5 Liquid Cooling

If subjected to extreme loads, e.g. during continuous start-stop operation with high repeat frequencies, the motors of the MHD093-...-...-N and MHD115-...-...-N motor type series, can be operated with liquid cooling.

The diagram below illustrates the connections of the coolant lines to the motor types MHD093-...-...-N and MHD115-...-...-N.

The connection for inlet and outlet is intended for connection elements with R1/8" thread.

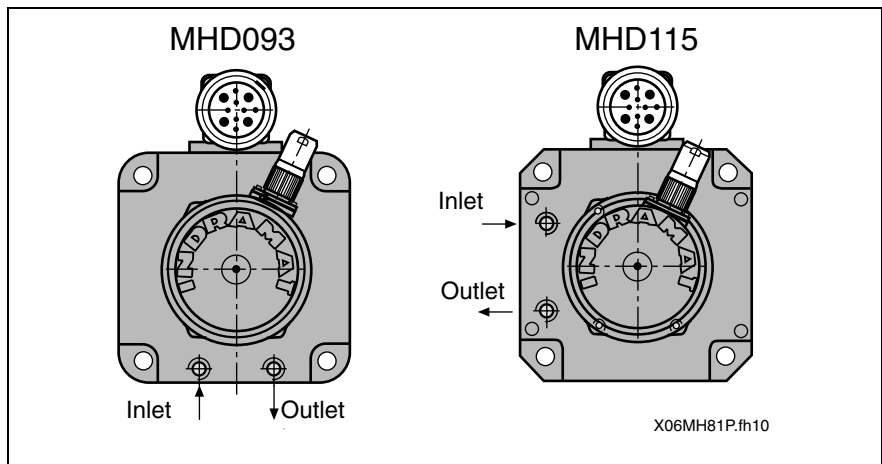

Fig. 16-15: Liquid cooling of MHD093 and MHD115

If motors are provided with liquid cooling, the liquid connection can be established in various ways:

Type of connection	Diagramm			
Line olive	Motor	Line olive with R1/8" thread	Line	Line clip
Quick coupler connection	Motor	Coupling with R1/8" thread	Coupling with clamped screw connection	Line
Clamped connection	Motor	Clamped connection with R1/8" thread	Line	

Y03MH81P.fh10

Fig. 16-16: Possible types of connection for liquid cooling

At the moment, it is not possible to procure the connection components required to this end from Bosch Rexroth. Please refer to the following documentation for instructions in selecting and dimensioning a heat disposal system: DOK-DIAX01-DRIVE***LIQ-AUS1-EN-P. It contains ordering data on the accessories required for liquid cooling and lists the addresses of manufacturers and suppliers of cooling system components.

Connection Instructions

Coolant lines Coolant lines can be designed either as pipeline or as tubing system.

Note: Owing to the turning points inevitably present in pipeline systems (e.g. 90-degree elbows), high pressure losses develop in the cooling lines. For that reason, we recommend that tubing systems be used.

When selecting the coolant lines, please be absolutely sure to take the pressure drop within the system into consideration. If greater lengths are used, the inside diameter of the lines should, therefore, at least be 9 mm and be reduced only shortly before being connected to the motor.

Coolants The data specified in the documentation relate to **water as coolant**.

Pressure drop The flow in the coolant in the drive components is subject to changes in cross-section and direction. For that reason, there are friction and turning losses. These losses show as the pressure drop Δp .

The pressure drop Δp_n of the liquid-cooled motors is specified in the technical data. It relates to the specified flow volume of water as coolant. If the flow volume is converted to a different temperature increase, the pressure drop must be taken from the characteristic curve below.

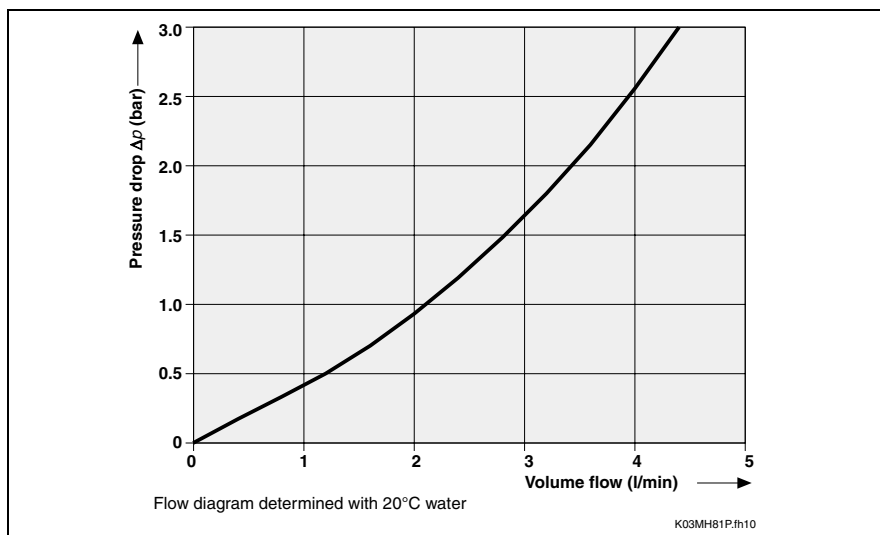

Fig. 16-17: Flow diagram for MHD motors

Note: If a different coolant is used, a different coolant-specific flow diagram is applicable.

Additional documentation Please refer to the documentation entitled "Liquid Cooling of INDRAMAT Drive Components" (DOK-DIAX01-DRIVE***LIQ-AUS1-EN-P), material number 265 836, for advanced information on additives and other coolants.

16.6 Holding Brakes

Use the brake in **normal operation** only at a standstill and when performing the drive-internal brake check. The holding brake is required for holding the axle when the machine is in a de-energized state.



Hazardous movements! Persons endangered by falling or descending axles!

⇒ Observe supplementary DIN and recommendations.

For European countries:

- DIN EN 954 / 03.97 on security-related parts of controllers.

- Instruction sheet for vertical axes

Issued by:

Süddeutsche Metall-Berufsgenossenschaft

Fachausschuss Eisen und Metall II

Wilhelm-Theodor-Römheld-Str. 15

55130 Mainz, Germany

USA: See National Electric Code (NEC), National Electrical Manufacturers Association (NEMA) as well as local building regulations.

The following is generally valid: The national terms must be observed!

⇒ The serially delivered motor holding brake does not suffice to ensure protection of persons!

⇒ Ensure protection of persons by superordinate fail-safe measures.

⇒ Cordon off the hazardous area by means of a safety fence or a safety screen.

⇒ Additionally secure vertical axes to prevent them from falling or descending after having switched off the motor, for instance as follows:

- lock the vertical axis mechanically,

- provide an external braking / collecting / clamping device, or

- ensure proper weight compensation of the axis.

- Miscellaneous suitable measures.

Brake control

The brake's control mechanism must ensure this function in normal operation. Under the worst load condition of the power supply with a voltage of $24 V_{DC} \pm 10\%$ must be supplied to the motor. To identify a failure on time during operation, the power supply for the brakes must be monitored by an undervoltage detection system.

Functional test Before start-up and during operation specifications the brake function must be tested with the “brake command” function. By applying a small amount of motor torque, the brake is tested for slippage. Additional information and specifications of this function may be found in the ECODRIVE firmware functional descriptions.

Selecting Holding Brakes

Brakes are either electrically clamping or electrically releasing. Due to functional differences, different brakes should be used for main spindle and servo-axes. Observe the safety requirements during the plant design.

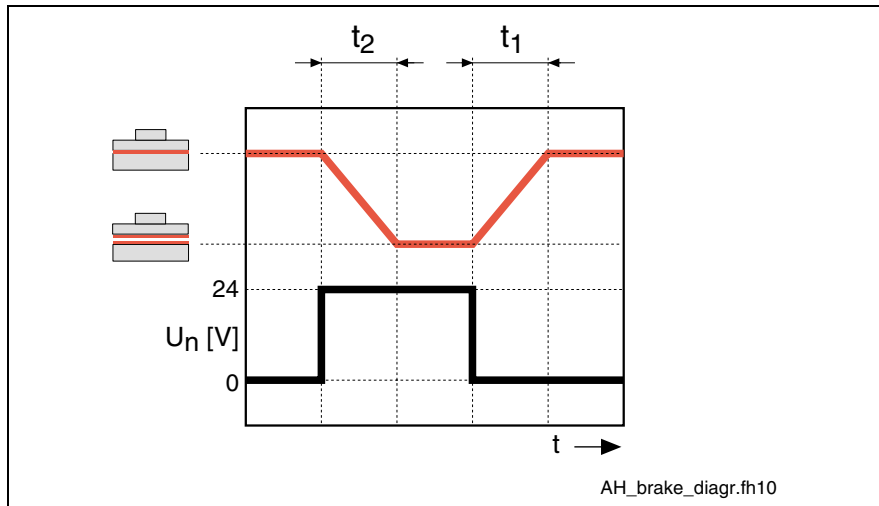

t_1 : Connection time
 t_2 : Disconnection time

Fig. 16-18: Holding brake diagram

Servo Applications

Electrically releasing holding brake

The **electrically releasing** holding brake is used to hold the axis at a standstill and when the “controller enable” signal is off. When the supply voltage fails, the **electrically releasing** brake will automatically close.

- ⇒ Do not use the holding brake as an operational brake for moving axes.
- ⇒ For hanging axes, switch off the “controller enable” signal only after the mechanism has stopped and is clamped by the holding brake.

If the brake is engaged repeatedly on a drive in motion or the rated brake torque is exceeded, premature brake wear can occur.

The **electrically clamping** holding brake is inappropriate for servo applications because clamping in a de-energized clamping state is not possible.

Sizing of Holding Brakes (Application)

The physical conditions of holding brakes require consideration of two states. Beyond the normal operation also the incident must be viewed. The effective braking torques are physically different.

Normal Operation

In normal operation, using the holding brake for clamping of an axis standstill, the brake's static torque (M4) rating in the data sheets applies directly as static friction (M4) – stiction (friction coefficient μ_H).

Fault Condition (EMERGENCY STOP)

In fault conditions (i.e., EMERGENCY STOP), where the holding brake is used to stop a moving axis, the "dynamic braking torque", or sliding friction (friction factor μ_G) applies.

The dynamic braking torque is reduced in comparison to the indicated static holding torque M4. Therefore, note the following description of dynamic sizing.

Dynamic sizing The load torque must be smaller than the minimum dynamic torque which the brake can provide. Otherwise the dynamic brake torque is not sufficient to stop the axis.

If a mass should be decelerated in a determined time or in a determined way, the additional moment of inertia of the whole system must be taken into account.

Further important aspects for sizing:

The holding brake is not a safety brake (see DIN EN 954 / 03.97 and vertical axis data sheet SMBG). As a result of uncontrollable influencing factors such as rust film on the brake surface, the brake holding torque can be reduced. Additionally, excessive voltage and temperature can weaken the permanent magnets and the brake.

Sizing recommendation Bringing these factors together, the following recommendations can be given for sizing the holding brakes to the axles.

The necessary holding torque required for the application must not exceed a maximum of 60% of the static holding torque (M4) of the used holding brake.

Note: **Holding torque reduction and premature wear occur when braking moving axles!**

Do not use the holding brake to stop a moving axle! This is permitted for EMERGENCY STOP situations only. In this situation, the specified rated torque of the holding brake (M4) is reduced to the value of the available dynamic braking torque. Complete deterioration of brake holding capability can be expected after approximately 20,000 revolutions of the brake when clamped.

Observe the instructions on commissioning holding brakes as described in the chapter "Startup, Operation, and Maintenance".

16.7 Output Shaft and Motor Bearing

Plain Shaft

The standard design recommended for MHD motors provides a friction-locked shaft-hub connection without play and excellent running smoothness. Use clamping sets, clamping sleeves or clamping elements to couple the machine elements to be driven.

Output Shaft With Featherkey

The optional featherkey according to DIN 6885, Sheet 1, version 08-1968, permits keyed transmission of torques with constant direction, with low requirements for the shaft-hub connection.

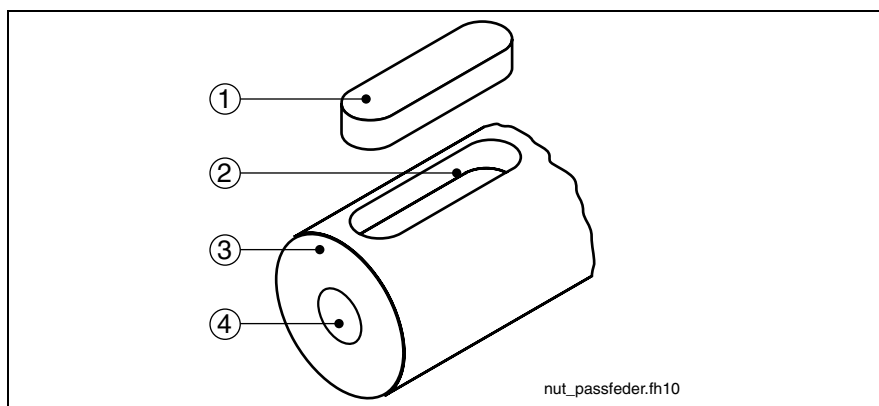

- (1): Fitting spring
- (2): Keyway
- (3): Motor shaft
- (4): Centering hole

Fig. 16-19: MHD output shaft with featherkey

The machine elements to be driven must additionally be secured in the axial direction via the centering hole on the end face.



CAUTION

Shaft damage! In case of intense reversing operation, the seat of the featherkey may deflect. Increasing deformations in this area can then lead to a break of the shaft!

⇒ Preferably, plain output shafts should be used.

Balancing with a complete featherkey

MHD motors are balanced with the **complete** featherkey. Hence, the machine element to be driven must be balanced without a featherkey. The keyway length in the hub is independent of the length of the featherkey.



Modifications to the featherkeys may be made only by the user himself and on his own responsibility. Bosch Rexroth do not give any warranty for modified featherkeys or motor shafts.

Output Shaft With Shaft Sealing Ring

MHD motors are designed with radial shaft sealing rings according to DIN 3760 – design A.

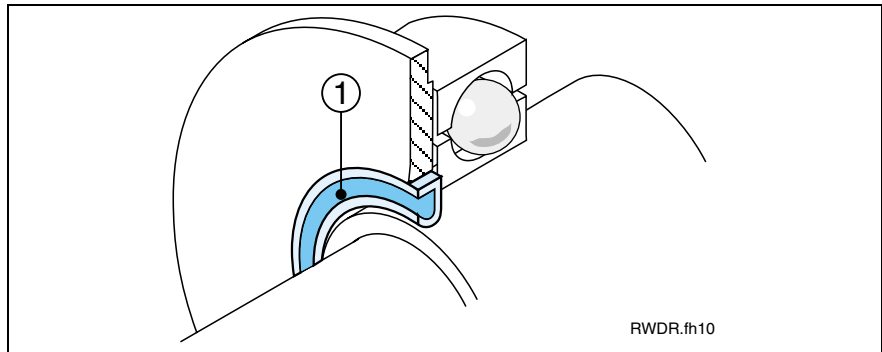

(1) Radial shaft sealing ring

Fig. 16-20: MHD radial shaft sealing ring

Wear Radial shaft sealing rings are rubbing seals. Hence, they are subject to wear and generate frictional heat.

Wear of the rubbing seal can be reduced only if lubrication is adequate and the sealing point is clean. Here, the lubricant also acts as a coolant, supporting the discharge of the frictional heat from the sealing point.

⇒ Prevent the sealing point from becoming dry and dirty. Always ensure adequate cleanliness.

Note: Under normal environmental conditions the shaft seal is greased for lifetime. Under unfavourable environmental conditions (e.g. grinding dust, scops) maintantace could be necessary.

Resistance The materials used for the radial shaft sealing rings are highly resistant to oils and chemicals. The performance test for the particular operating conditions lies, however, within the machine manufacturer's responsibility. As of the publication date of this document, the following material assignment is applicable:

Motor	Sealing material	Short name
MHD	Fluorocaoutchouc	FPM (Viton)

Fig. 16-21: MHD shaft sealing ring



The complex interactions between sealing ring, shaft and fluid to be sealed as well as the particular operating conditions (frictional heat, soiling, etc.) do not allow calculation of the lifetime of the shaft sealing ring.

**Vertical installation positions
IM V3**

The degree of protection on the flange side of motors with a shaft sealing ring is IP 65. Hence, tightness is ensured only in case of splashing fluids. Fluid levels present on side A require a higher degree of protection. If the motor is installed in vertical position (shaft pointing up), the instructions in the section "Design and Installation Positions" in this chapter must, in addition, be observed.

Note on construction Bosch Rexroth recommend that any direct contact of the output shaft and the radial shaft sealing ring with the processing medium (coolant, material corrosion), caused by the type of machine or system construction, should be avoided.

Bearings and Shaft Load

During operation, both radial and axial forces act upon the motor shaft and the motor bearings. The construction of the machine and the attachment of driving elements on the shaft side must be adjusted to one another to ensure that the load limits specified are not exceeded.

Radial load, axial load

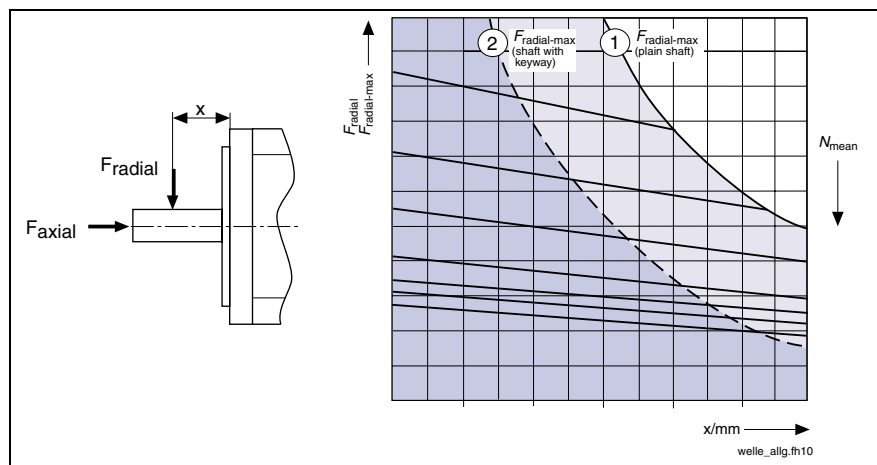

- (1): $F_{\text{radial_max}}$ (plain shaft)
 (2): $F_{\text{radial_max}}$ (shaft with keyway)

Fig. 16-22: Example of a shaft load diagram

Maximum permissible radial force $F_{\text{radial_max}}$

The maximum permissible radial force $F_{\text{radial_max}}$ depends on the following factors:

- Shaft break load
- Point of force application x (see Fig. 16-22)
- Shaft design (plain; with keyway)

Permissible radial force F_{radial}

The permissible radial force F_{radial} depends on the following factors:

- Arithmetic mean speed (n_{mean})
- Point of force application x (see Fig. 16-22)
- Bearing service life

Permissible axial force F_{axial}

The maximum permissible axial force F_{axial} is proportional to the radial force. Please refer to the section entitled "Shaft load" in the technical data for the proportionality factor.

Note: Owing to thermal effects, the flange-sided end of the output shaft may shift by 0.6 mm in relation to the motor housing. If skew bevel driving pinions or bevel gear pinions directly attached to the output shaft are used, this change in position will lead to

- a shift in the position of the axis, if the driving pinions are not defined axially on the machine side,
- to a thermally dependent component of the axial force, if the driving pinions are defined axially on the machine side. This causes the risk of exceeding the maximum permissible axial force or of the play within the gearing increasing to an impermissible degree.

In such cases, you should, therefore, preferably use drive elements with their own bearings, which are connected to the motor shaft via axially compensating couplings.

Bearing service life

If the MHD motors are operated within the limits specified for radial and axial loads, the nominal service life of the bearings is as follows:

Nominal bearing service life

$L_{10h} = 30.000$ operating hours
(calculated according to ISO 281, ed. 12/1990)

In other cases, the bearing service life is reduced as follows:

$$L_{10h} = \left(\frac{F_{\text{radial}}}{F_{\text{radial_ist}}} \right)^3 \cdot 30000$$

L_{10h} : (Bearing service life according to ISO 281, ed. 12/1990)

F_{radial} : Determined permissible radial force in N (Newton)

$F_{\text{radial_ist}}$: Actually acting radial force in N (Newton)

Fig. 16-23: Calculation of the bearing service life L_{10h} if the permissible radial force F_{radial} is exceeded

Note: Under no circumstances may the actually acting radial force $F_{\text{radial_ist}}$ be higher than the maximum permissible radial force $F_{\text{radial_max}}$.

Attachment of drive elements

Redundant bearing

When attaching drive elements to the output shaft, be absolutely sure to avoid any redundant bearing. The tolerances inevitably present in such cases will lead to additional forces acting on the bearing of the motor shaft and, should the occasion arise, to a distinctly reduced service life of the bearing.

Note: If a redundant attachment cannot be avoided, it is absolutely necessary to consult with Bosch Rexroth.

16.8 Motor encoder

To control the motor speed and/or to position the motor, the drive controller requires information on the current motor position.

To achieve this, the integrated encoder unit makes the appropriate signals available to the drive controller. The drive controllers are capable of transmitting the positional value thus determined to a superordinate CNC or SPS.

The encoder electronics is equipped with a data memory where the motor type name, the control loop parameters and the motor parameters are filed.

These data are read by the digital intelligent drive controllers by Bosch Rexroth. This ensures

- quick and easy startup,
- adjustment between the motor and the drive controller without the risk of damage to the motor.

MHD motors are available with the two following types of position detectors:

- Relative position detector
- Absolute position detector

Technical data of motor encoder

Description	Digital servo feedback (HSF)	Digital servo feedback (HSF) with integrated multiturn absolute encoder
Measurement method	Optically	
Position resolution at the motor	$512 \times 2^{13} = 4.194.304$ bits of information / revolution	
System accuracy	± 0.5 angular minutes	
Type of position detector	Relative	Absolute (more than 4096 motor revolutions)

Fig. 16-24: Technical data of motor encoder

Digital servo feedback (HSF) Provided for relative indirect position detection. Replaces separate incremental encoders at the motor.

Note: After a voltage failure or after the first POWER ON, the axis must first always be moved to its home position.

Digital servo feedback (HSF) with integrated multiturn absolute encoder Provided for absolute indirect position detection within 4096 motor revolutions. Replaces separate absolute value encoders at the motor.

With this encoder version, the absolute position of the axis is preserved even after voltage switchoff.

16.9 Acceptances, Approvals

CE symbol

Declaration of conformity Declarations of conformity certifying the structure of and the compliance with the applicable EN standards and EC guidelines are available for all MHD motors. If necessary, these declarations of conformity can be requested from the pertinent sales office.

The CE mark is applied to the motor type label of the MHD motors.

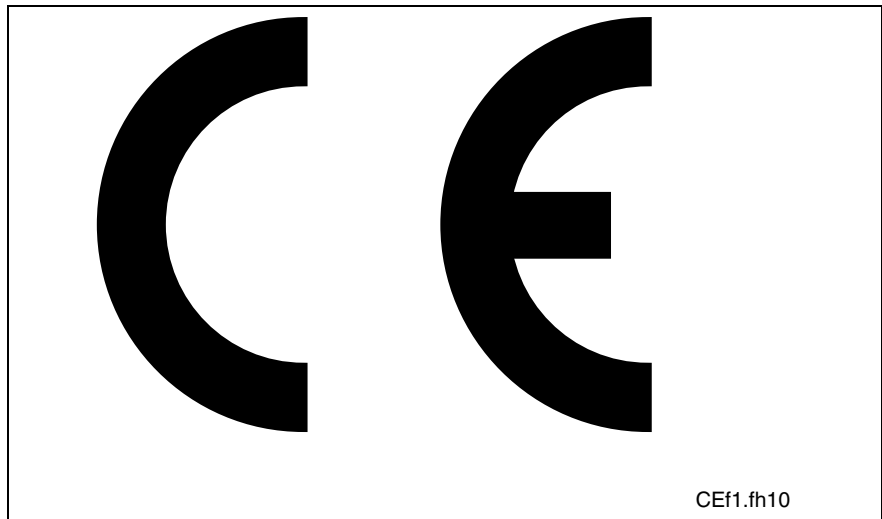

Fig. 16-25: CE symbol

UR, cUR Listing

The MHD motors listed below have been presented to the UL authorities "Underwriters Laboratories Inc.®".

- MHD041A, -B
- MHD071A, -B
- MHD090B
- MHD093A, -B, -C
- MHD112A, -B, -C, -D
- MHD115A, -B, -C

The motors have been approved by the UL authorities under the file number **E163211** and have been marked on their motor type label with the following sign:



Fig. 16-26: cUR mark

17 Handling

17.1 Identifying the Goods

Delivery note A single copy of the delivery note is enclosed to each delivery. The delivery note lists all components with their ordering name and their designation. If the contents are distributed among several parcels (transport containers), then this is noted on the delivery note or it can be seen from the freight bill.

Bar code label Each motor package is provided with a bar code label providing the following data:

- Type name of the motor
- Customer
- Delivery note number
- Consignment
- Forwarding agent ordered

The bar code label is provided for identification of the contents during processing of the order.

17.2 Type Labels

Motor The motor is delivered including a type label. The type label is attached to the motor housing. In addition, a second type label is adhered onto the original type label on the motor housing, using double-sided adhesive tape. The latter type label can be put well visible on the machine, if the original type label on the motor be concealed by parts of the machine.

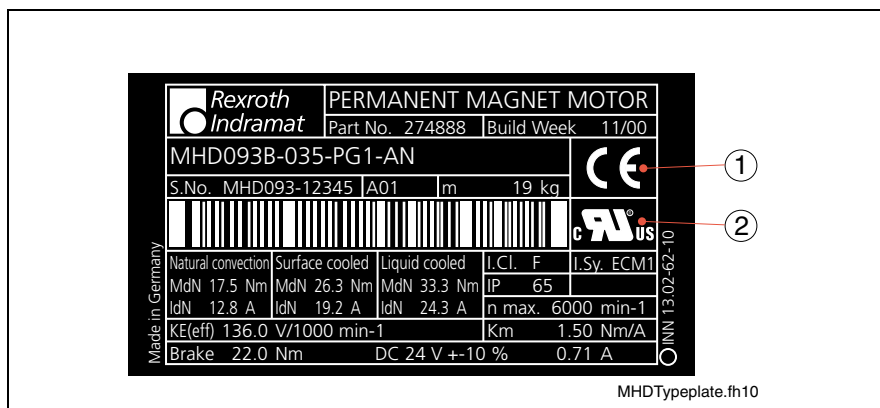

(1) CE symbol

(2): cUR mark; not applicable in case of non-approved motor types

Fig. 17-1: MHD type label (example)

The type label is provided for

- identification of the motor,
- procurement of spare parts in case of a failure,
- service information.

Note: The type name of the motor is also filed in the encoder data memory.

Cable sets Cable sets by Bosch Rexroth are identified by a cable type label (label at the end of the cable). The cable type label specifies the ordering name as well as the length of the cable.

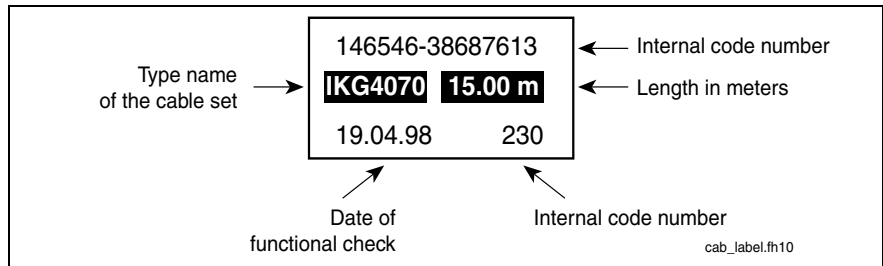

Fig. 17-2: Cable type label

Non-prepared cables
Raw cable type The name of the raw cable type is printed on the cable sheath. When ordering raw cables, the desired length in meters must be specified in addition to the raw cable type.

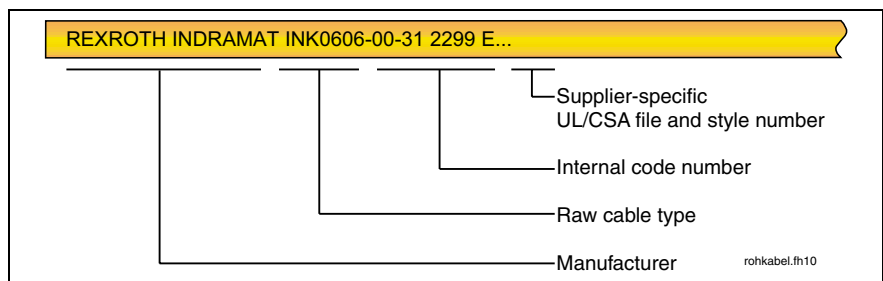

Fig. 17-3: Raw cable name

17.3 Instructions on the Packing

Instructions on storage, transport and handling of the parcels are printed on the packing. It is absolutely necessary that these instructions be observed.

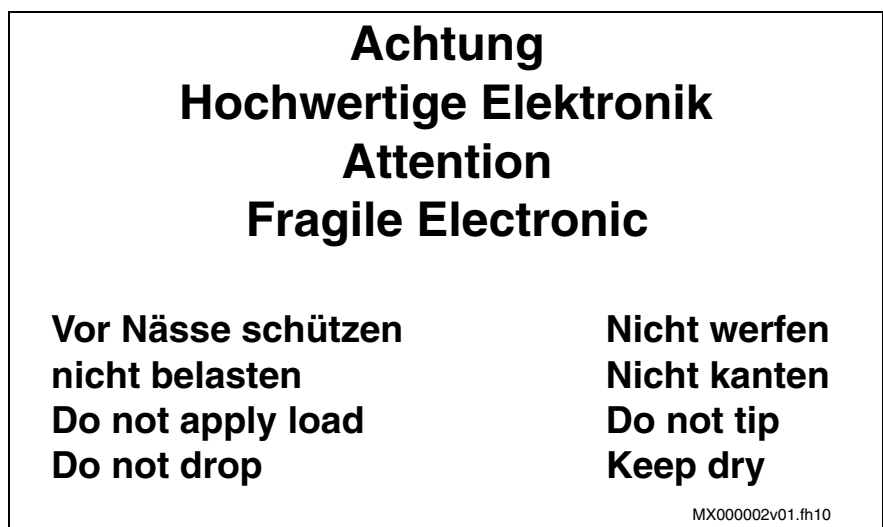

Fig. 17-4: Instructions on storage, transport and handling on the packing

17.4 Storage



WARNING

Damage to motor and loss of warranty possible!

Any improper storage may cause damage to the motor.

In addition, any warranty claim will expire.

= For that reason, please observe the following instructions.

The following conditions must be kept during storage:

- Permissible range of temperature: -20°C up to $+80^{\circ}\text{C}$.
- Store motors at dry places which are free from dust and vibrations.
- Store motors horizontally.
- Do not remove the plastic protective sleeve on the drive shaft. It protects the shaft from moisture and mechanical damage.

17.5 Transport and Handling



WARNING

Damage to motor and loss of warranty possible!

Improper transport and handling may cause damage to the motor. In addition, any warranty claim will expire.

= For that reason, please observe the following instructions.

The following conditions must be kept during transport and handling:

- Use the appropriate means for transport. Take the weight of the components into consideration (weights are specified in the chapters pertaining to the various motors, in the sections on technical data and/or on the type label of the motor).
- Provide for shock absorption, if strong vibrations may occur during transport. Please also observe the limits specified in Chapter 12.5, "Maximum Vibration and Shock Loads".
- Transport only in horizontal position.
- Use cranes with lifting sling belts to lift the motors.
- Avoid damage to the motor flange and the drive shaft.
- Avoid impacts on the drive shaft.
- Remove the plastic protective sleeve from the drive shaft only shortly before mounting the motors.

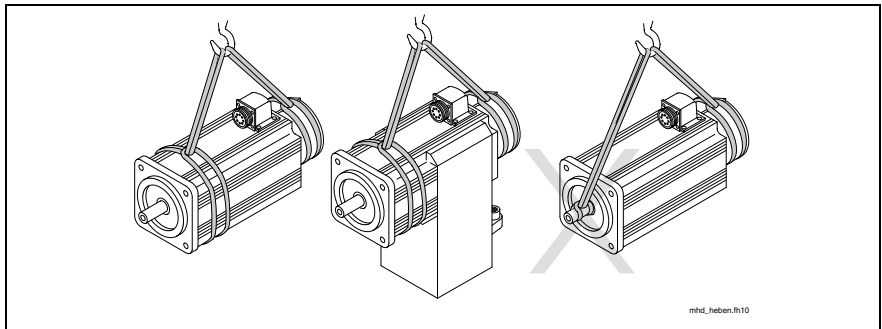

Fig. 17-5: Lifting and transporting the motors by means of lifting sling belts

18 Assembly

18.1 Skilled Technical Personnel

Any work on the system and on the drives or in their vicinity may only be carried out by appropriately trained technical personnel. The owner of the system must ensure that all persons carrying out

- installation work,
- maintenance measures, or
- operation activities

on the system are adequately familiar with the contents of this documentation as well as with all warnings and precautionary measures contained therein. Qualified technical personnel must have been trained and instructed and are authorized to activate and deactivate, ground and mark electric circuits and equipment according to the safety rules and regulations. Qualified technical personnel must possess the appropriate safety equipment and have been trained in first aid.

18.2 Mounting the Motor

General information on mounting

Observe all warnings and safety advice mentioned in Chapter 3. This minimizes the risk of accidents and damage to the system or the motor.

Execute all handling instructions very carefully. This ensures correct mounting and dismounting of the components.

MHD motors comply with design B5 in accordance with DIN 42950, Part 1, ed. 08.77. Please refer to the dimensional sheets in Chapters 6 to 13 for all relevant dimensional details.

Before mounting:

1. Procure tools, auxiliary materials, measuring and test equipment.
 2. Check all components for cleanliness.
 3. Check the components for visible damage. Defective components may not be mounted.
 4. Ensure that mounting can be done in a dry and clean environment.
 5. Ensure that the holder for the motor flange is without burrs.
- If the optional holding brake is used**
6. Check whether the motor holding brake reaches the holding torque specified in the data sheet. Should the brake fail to reach the torque specified, first grind in the holding brake as described under the "Holding Brake" section in Chapter 19. Then proceed as follows:
- If the optional liquid cooling is used**
7. If you intend to use a liquid-cooled motor, establish the liquid connection and check the coolant lines for tightness by exerting a pressure of 5 bar. Also ensure that the flow volume required flows through the motor.

Mounting the MHD motors:

Mount the motor. All of the measures and tolerances specified in the dimensional sheets must be kept.

To fix the flange, we recommend to use the screws and tightening torques listed in the table below.

Motor Frame Size	Recommended screw size	Tightening torque [Nm]	Minimum strength
MHD041	4 x M6	10,4	8.8
MHD071	4 x M8	25	8.8
MHD090	4 x M10	51	8.8
MHD093	4 x M10	51	8.8
MHD095	4 x M10	51	8.8
MHD112	4 x M12	87	8.8
MHD115	4 x M12	87	8.8
MHD131	4 x M16	215	8.8

Fig. 18-1: Locking screws

Note: The screwed connections must be able to take up both the force due to the weight of the motor and the forces acting during operation.

18.3 Connecting the Motor

After having mounted the motor mechanically as specified, proceed to connecting the motor.



DANGER

Danger to life by electric voltage! Handling within the range of live parts is extremely dangerous. Therefore:

- = Any work required on the electric system may only be carried out by skilled electricians. It is absolutely necessary to use electric tools.
- ⇒ Before starting work, the system must be de-energized and the power switch be secured against unintentional or unauthorized re-energization.
- = Before starting work, the appropriate measuring equipment must be used to check whether parts of the system are still applied to residual voltage (e.g. caused by capacitors, etc.). If yes, wait until these parts have discharged.



WARNING

Injuries to persons or property are possible! Interrupting or connecting live lines may cause unpredictable dangerous situations or lead to physical damage. Therefore:

- = Connect and disconnect plug connectors only when they are dry and de-energized.
- = During operation of the system, all plug connectors must be securely tightened.



WARNING

Risk of short-circuit caused by liquid coolant or lubricant! Short-circuits of live lines may cause unpredictable dangerous situations or lead to physical damage. Therefore:

- = Provide open mating sides of power plug connectors with safety caps when installing or replacing drive components, if you cannot exclude that they might be moistened with liquid coolant or lubricant.

The connection diagrams by Bosch Rexroth are exclusively intended for the preparation of system circuit diagrams!

- ⇒ Connect the motor as specified in the machine manufacturer's system circuit diagram! Refer to the connection diagram in Chapter 15 for support.

Connecting Cable Sets

Power cables

**Fitting the power connector for
MHD041
MHD071
and MHD090**

When fitting the INS0681 power connector with thread, proceed as follows:

1. Put the power connector onto the thread of the connection housing in the correct position.
2. Tighten the union nut of the power connector manually. By leading the cable in further, the power connector can be steadily put to its final position.
3. Tighten the union nut as securely as you can manually.

**Fitting the power connector for
MHD093 - MHD131**

When fitting the INS0381 or INS0481 power connector with bayonet lock, proceed as follows:

1. Put the power connector onto the bayonet lock of the connection housing in the correct position.
2. Turn the union nut of the power connector in manually until it snaps into the final position (i.e. when the red dots comply with the red triangles).

Encoder cable

**Assembly of the encoder
connector**

When fitting the encoder connector, proceed as follows:

1. Put the encoder connector onto the thread of the connection housing in the correct position.
2. Tighten the union nut of the power connector manually. By leading the cable in further, the encoder connector can be steadily put to its final position.
3. Tighten the union nut as securely as you can manually.

Changing the Output Direction of Power and Feedback Connectors

Power connectors

Changing the connector output direction at MHD041
MHD071
MHD090

In case of the motors MHD041, MHD071, and MHD090, you can select the output direction of the power connector when mounting these motors. The flange sockets are designed such that they can be turned (angle of rotation of 270 degrees).

Adjustment of the desired cable output direction is described below.

Note: Do not use any tools (e.g. tongs or pliers or screwdrivers) to turn the motor flange socket. Mechanical damage to the flange socket cannot be excluded.

The motor flange socket can be turned easily if an appropriate plug has been connected. Owing to the leverage of the connected plug, the flange socket can be turned manually to the desired output direction.

Proceed as follows:

1. Connect the motor power cable to the flange socket.
2. Put the flange socket to the desired output direction by turning the connected plug.

The desired output direction is set.

Note: Whenever the flange socket is turned, the holding torque in the set position is reduced. To ensure the required holding torque of the flange socket, the cable output direction should be changed no more than 5 times!

It is not necessary to “rebuild” the flange socket (i.e. dismantling and mounting the flange socket, relocated by 90 degrees). The following problems and risks can arise should the flange socket be “rebuilt”:

- The O-ring seal between the flange socket and the motor housing is not ensured any longer.
- The tightening torques prescribed are, perhaps, not kept.
- The TFL coating (screw locking element) of the locking screws will wear by unscrewing, thus becoming ineffective.

Note: No warranty!

If the cable output direction is changed by “**rebuilding**” the flange socket, the warranty for the overall drive system given by BOSCH REXROTH will expire. The cable output direction may only be changed by turning the flange socket.

Changing the cable output direction at MHD093 – MHD131

If the cable output direction of the power connector of the MHD093 – MHD131 motors were not considered when ordering them and now fails to be the direction desired, it can be turned.

To achieve this, proceed as follows:

1. Loosen the two locking screws (4) and remove the cover of the flange socket (2).
2. Loosen the four locking screws (3).
3. Now turn the flange socket housing (1) into appropriate position (by steps in 90°).
4. Ensure that cable strands are prevented from being damaged or tensioned unnecessarily.
5. Retighten the four locking screws (3) (tightening torque: 3.1 Nm \pm 10%).
6. Ensure that, when retightening the screws, cable strands and the seal are prevented from being damaged.
7. Reattach the cover of the flange socket (2) to the connector housing (1) and retighten the two locking screws (4) (tightening torque: 3.1 Nm \pm 10%).

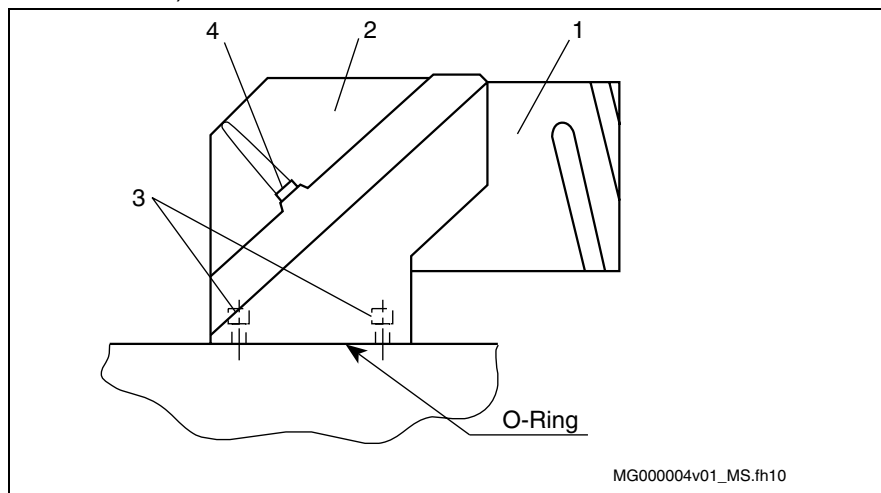

Fig. 18-2: Power connector

Note: The connector output direction can be selected upon ordering by specifying it accordingly in the type code (output direction A, B, L, R).

Encoder connector

Changing the connector output direction at MHD041 MHD071 MHD090

In case of the motors MHD041, MHD071, and MHD090, you can select the output direction when mounting these motors. The flange sockets are designed such that they can be turned (angle of rotation of 270 degrees). Adjustment of the desired connector output direction is described below.

Note: Do not use any tools (e.g. tongs or pliers or screwdrivers) to turn the motor flange socket. Mechanical damage to the flange socket cannot be excluded.

The motor flange socket can be turned easily if an appropriate plug has been connected. Owing to the leverage of the connected plug, the flange socket can be turned manually to the desired cable output direction.

Proceed as follows:

1. Connect the encoder cable to the flange socket.
2. Put the flange socket to the desired output direction by turning the connected cable.

The desired output direction is set.

Note: Whenever the flange socket is turned, the holding torque in the set position is reduced. To ensure the required holding torque of the flange socket, the output direction should be changed no more than 5 times!

It is not necessary to “rebuild” the flange socket (i.e. dismantling and mounting the flange socket, relocated by 90 degrees). The following problems and risks can arise should the flange socket be “rebuilt”:

- The O-ring seal between the flange socket and the motor housing is not ensured any longer.
- The tightening torques prescribed are, perhaps, not kept.
- The TFL coating (screw locking element) of the locking screws will wear by unscrewing, thus becoming ineffective.

Note: No warranty!

If the cable output direction is changed by “**rebuilding**” the flange socket, the warranty for the overall drive system given by BOSCH REXROTH will expire. The cable output direction may only be changed by turning the flange socket.

Changing the cable output direction at MHD093 – MHD131

Should the cable output direction of the angular encoder connector of the MHD093 – MHD131 motors not be the desired direction, it can be turned by 90 degrees. To achieve this, proceed as follows:

1. Loosen the four locking screws on the top of the connector.
2. Turn the plug part with union nut in relation to the connector housing into the desired position (in increments of 90 degrees).
3. Retighten the locking screws (tightening torque: 0.8 Nm \pm 10%).
4. Ensure that, when retightening the screws, cable strands and the seal are prevented from being damaged.

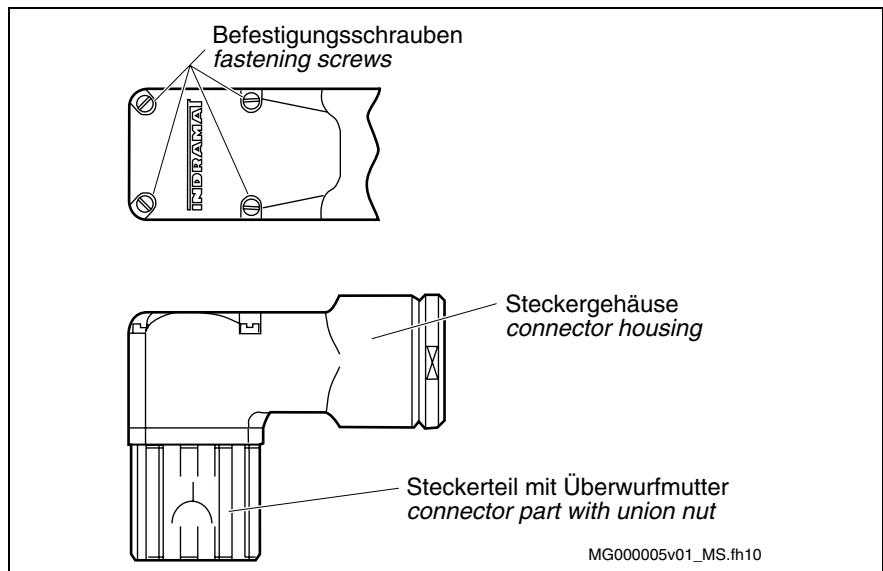

Fig. 18-3: Angular connector (encoder unit)

Note: In case of applications with high vibration and shock loads, the angular connector must be secured against loosening by means of screw locking adhesive.

19 Startup, Operation, and Maintenance

19.1 Commissioning

The MKD motors may be put into operation only if they have been carefully and properly mounted and if the electric connection has been properly established.

Before startup Before putting the MHD motors into operation, the following must be checked and/or ensured:

- It must be possible to turn the rotor manually with the holding brake opened; there may be no running noise (e.g. rubbing). If necessary, the holding brake must be opened by applying a DC voltage of 24 V $\pm 10\%$.
- The motor must be mounted and aligned correctly. The motor flange must be coupled to the machine structure or the gear absolutely even.
- It must be ensured that all electric connections (motor and drive controller) have been established as specified and that the cable screw unions have been tightened.
- It must be ensured that the protective conductor and/or the protective grounding have been executed properly.
- If the optional holding brake is used, its operational reliability must be ensured.
- Shock protection measures against live and moving parts must be provided for.

Commissioning MHD motors may be put into operation only with drive controllers by Rexroth Indramat. After the connection has been properly established and the above requirements are complied with, the MHD motor can be put into operation via the drive controller.

Note: Startup of the drives is described in the product documentation of the particular drive controllers. Request the corresponding product documentation from your local sales office.

19.2 Operation

Ensure that the ambient conditions described in Chapter 16, "Application Instructions", are kept during operation.

19.3 Maintenance

Cleaning

Excessive dirt, dust or shavings may affect the function of the motors adversely, may in extreme cases even cause a failure of the motors. For that reason, you should clean

- Cooling ribs**
- the cooling ribs of the motors at regular intervals, in order to obtain a sufficiently large heat radiation surface. If the cooling ribs are dirty in part, sufficient heat dissipation via the environmental air is not possible any longer.

An insufficient heat radiation may have undesired consequences. The bearing service life is reduced by operation at impermissibly high temperatures (the bearing grease is decomposing). Switchoff caused by overtemperature despite operation on the basis of selected data, because the appropriate cooling is missing.

Bearing

The nominal service life of the bearings is $L_{10h} = 30.000$ h according to DIN ISO 281, ed. 1990, if the permissible radial and axial forces are not exceeded (see Chapter 16.7). Even if the bearings are loaded with higher forces to a minor degree only, their service life is affected negatively.

The motor bearings should be replaced if

- the nominal bearing service life has been reached,
- running noise can be heard.

Note: We recommend that bearings are replaced by the Bosch Rexroth Service.

Connection Lines

Check connection lines for damage at regular intervals and replace them, if necessary.

Check any optionally present energy management chains (drag chains) for defects.



Electrocution by live parts of more than 50 V!

⇒ Do not repair any connection lines provisionally. If the slightest defects are detected in the cable sheath, the system must be put out of operation immediately. Then the cable must be replaced.

Check the protective conductor connection for proper state and tight seat at regular intervals and replace it, if necessary.

Holding Brake

In order to ensure proper functioning of the holding brake, it must be checked before the motors are installed.

Before initial startup Measure the holding torque of the brake; grind in the holding brake, if necessary.

Proceed as follows:

1. De-energize the motor and secure it against re-energization.
2. Measure the transmittable holding torque of the holding brake using a torque spanner. The holding torque of the brakes is specified in the data sheets.
3. If the holding torque specified in the data sheets is attained, the holding brake is ready for operation.
If the holding torque specified in the data sheets is not attained, the holding brake must be ground in as described in step 4.
4. Grinding in: With the holding brake closed, manually turn the output shaft by approx. five revolutions and measure the transmittable holding torque of the brake using a torque spanner.
5. If the holding torque specified in the data sheets is attained, the holding brake is ready for operation.
If the holding torque specified in the data sheets fails to be reached, repeat steps 4 and 5 of the grinding-in process.

If the specified holding torque is not attained after the second grinding-in process, the holding brake is not operable. Notify Rexroth Service.

During operation If holding brakes are required only sporadically (braking cycle >48 h) during operation, film rust may develop on the brake friction surface.

To prevent the holding torque from dropping below the specified holding torque, we recommend the grinding procedure described below:

Recommendation for grinding in	
Interval	Once in 48 h
Grinding-in speed	100 rpm
Number of grinding-in revolutions	1
Ambient temperature	-20 °C to +50 °C

Fig. 19-1: Recommended procedure for grinding in motor holding brakes

Note: The option of automatically implementing the grinding-in routine in the program run is described in the documentation of the particular drive controllers.



During normal operation, it is not necessary to grind in the brake. It is sufficient if the brake is activated twice a day by removing the controller enable signal.

20 Appendix

20.1 List of standards

Standard	Edition	Title	Concordance
89/392/EEC replaced by 98/37/EG	1998-06-22	Guideline 98/37/EC of the European Parliament and the Council dated June 22, 1998, for aligning the legal provisions and administrative regulations of the member states for machines	
89/336/EEC	1989-05-03	Guideline of the Council dated May 3, 1989, for aligning the legal provisions of the member states on electromagnetic compatibility	
DIN EN 50178; VDE 0160	1998-04	Electronic equipment for use in power installations; German version EN 50178:1997	EN 50178(1997-10)
DIN VDE 100-410; VDE 100 Part 410 IEC 60364-4-41	1997-01	Erection of power installations with nominal voltages up to 1000 V - Part 4: Protection for safety; Chapter 41: Protection against electric shock (IEC 60364-4-41:1992, modified); German version HD 384.4.41 S2:1996	HD 384.4.41 S2(1996-04); IEC 6036-4-41(1992-10)
DIN 332-2	1983-05	Center holes 60° with thread for shaft ends for rotating electrical machines	
DIN 6885-1	1968-08	Drive Type Fastenings without Taper Action; Parallel Keys, Keyways, Deep Pattern	
DIN EN 60034-1; VDE 0530 Part 1	2000-09	Rotating electrical machines - Part 1: Rating and performance (IEC 60034-1:1996, modified + A1:1997 + A2:1999); German version EN 60034-1:1998 + A1:1998 + A2:1999	EN 60034-1(1998-05); EN 60034-1/A1(1998-05); EN 60034-1/A2(1999-08); IEC 60034-1(1996-11); IEC 60034-1 AMD 1(1997-06); IEC 60034-1 AMD 2(1999-05)
DIN VDE 0298-4; VDE 0298 Part 4	1998-11	Application of cables and cords in power installations - Part 4: Recommended current-carrying capacity for sheathed and non-sheathed cables for fixed wirings in buildings and for flexible cables and cords	
DIN EN 60204-1; VDE 0113 Part 1	1998-11	Safety of machinery - Electrical equipment of machines - Part 1: General requirements (IEC 60204-1:1997 + Corrigendum 1998); German version EN 60204-1:1997 (In addition, DIN EN 60204-1 (1993.06) is applicable until 2001.07.01. DIN VDE 60204-1 (1993.06) is applicable until further notice as the reference standard for EN 60204-3-1 (1990.08), which has been published in Germany as DIN EN 60204-3-1 (1993.02).	EN 60204-1(1997-12); IEC 60204-1(1997-10)
DIN 42955	1981-12	Tolerances of shaft extension run-out and of mounting flanges for rotating electrical machinery, test	IEC 60072(1971)
DIN 748-3	1975-07	Cylindrical Shaft Ends for Electrical Machines	IEC 60072(1971)
DIN VDE 0530-14 replaced by DIN EN 60034-14; VDE 0530 Part 14	1997-09	Rotating electrical machines - Part 14: Mechanical vibration of certain machines with shaft heights 56 mm and higher; measurement, evaluation and limits of vibration (IEC 60034-14:1996); German version EN 60034-14:1996	EN 60034-14(1996-12); IEC 60034-14(1996-11)
DIN 42959-1		DIN 42959-1 unknown; please provide title	
IEC 721-3-3 replaced by DIN EN 60721-3-3	1995-09	Classification of environmental conditions - Part 3: Classification of groups of environmental parameters and their severities; section 3: Stationary use at weatherprotected locations (IEC 60721-3-3:1994); German version EN 60721-3-3:1995 Modified by DIN EN 60721-3-3/A2 dated July 1997	EN 60721-3-3(1995-01); IEC 60721-3-3(1994-12)
IEC 721-1 replaced by DIN IEC 60721-1	1997-02	Classification of environmental conditions - Part 1: Environmental parameters and their severities (IEC 60721-1:1990 + A1:1992 + A2:1995); German version EN 60721-1:1995 + A2:1995	EN 60721-1(1995-04); EN 60721-1/A2(1995-07); IEC 60721-1(1990-12); IEC 60721-1 AMD 1(1992-12); IEC 60721-1 AMD 2(1995-04)
DIN EN 60529; VDE 0470 Part 1	2000-09	Degrees of protection provided by enclosures (IP code) (IEC 60529:1989 + A1:1999); German version EN 60529:1991 + A1:2000 (In addition, DIN VDE 0470-1 (1992-11) may still be used until 2003-01-01.)	EN 60529(1991-10); EN 60529/A1(2000-02); IEC 60529(1989-11); IEC 60529 AMD 1(1999-11)

DIN EN 60034-7; VDE 0530 Part 7	1996-06	Rotating electrical machines - Part 7: Classification of types of constructions and mounting arrangements (IM code) (IEC 60034-7:1992); German version EN 60034-7:1993	EN 60034-7(1993-01); IEC 60034-7(1992-12)
DIN 3760	1996-09	Rotary shaft lip type seals	
DIN ISO 281	1993-01	Rolling bearings; dynamic load ratings and rating life; identical with ISO 281:1990	

Fig. 20-1: List of standards

20.2 Selecting Power Cables

The tables and diagrams shown on the following pages are intended to support you in selecting the power cables required. The example below explains how to proceed.

Example A power cable set, **5.0 m in length**, is needed for a **MHD093A-024** motor, **Natural 60K** operating mode, and an **HDS02**. drive controller.

Proceed as follows:

1. Select the motor and the operating mode in the cable selection table.
2. "X" identifies the connection cross-section required.
3. Read the size of the power connector and the connection cross-section from the table header.
4. On the following pages, select the corresponding selection diagram by connector size and connection cross-section.
5. Select the required power cable set in the diagram. Complete the selected ordering type **IKGxxxx/xxx.x** by the desired length.

In the example above, the ordering type **IKG4055/xxx.x** is taken from the selection diagram. For ordering, complete the ordering type by the desired length.

Ordering type: IKG4055/005,0

21-2 Anhang
Digitale AC- Motoren MHD

21.1 Kabelauswahl

Motor MHD	Betriebsart	21-8 Anhang					
		INS0680, 1,0mm ²	INS0680, 1,5mm ²	INS0680, 2,5mm ²	INS0480, 1,5mm ²	INS0480, 2,5mm ²	
041A-144	Natural 60K	X					
041B-144	Natural 100K	X					
071A-035	Natural 60K	X					
071A-061	Natural 100K	X					
090B-035	Natural 60K	X					
090B-047	Natural 100K	X					
090B-058	Surface 60K/100K		X				
093A-024	Natural 60K			X			
093A-035	Surface 60K/100K			X			
093A-058	Natural 100K				X		
	Liquid 60K/100K				X		
	Liquid 60K/100K				X		
	Natural 60K				X		

21-8 Anhang
Digitale AC- Motoren MHD

INS0480 1,5mm²

Direct connection

Connection with adapter plug

Kabelauswahl.fh10

- (1): Select motor type and operating mode.
- (2), (3): Read the connector size and the cross-section off the column header.
- (4): Consult the corresponding diagram.
- (5): Select the desired cable.

Fig. 20-2: Instruction for cable selection (example)

MHD motor	Mode of operation	INS0680, 1.0mm ²	INS0680, 1.5mm ²	INS0680, 2.5 mm ²	INS0480, 1.5mm ²	INS0480, 2.5mm ²	INS0480, 4.0mm ²	INS0480, 6.0mm ²	INS0480, 10.0 mm ²	INS0380, 6.0mm ²	INS0380, 10.0mm ²	INS0380, 16.0mm ²	INS0380, 25.0mm ²	INS0380, 35.0 mm ²
041A-144	Natural 60K	X												
	Natural 100K	X												
041A-144	Natural 60K	X												
	Natural 100K	X												
071A-035	Natural 60K	X												
	Natural 100K	X												
071B-035	Natural 60K	X												
	Natural 100K	X												
071B-061	Natural 60K	X												
	Natural 100K	X												
090B-035	Natural 60K	X												
	Natural 100K	X												
	Surface	X												
090B-047	Natural 60K	X												
	Natural 100K	X												
	Surface 60K/100K		X											
090B-058	Natural 60K	X												
	Natural 100K		X											
	Surface 60K/100K			X										
093A-024	Natural 60K				X									
	Natural 100K													
	Surface 60K/100K				X									
	Liquid 60K/100K				X									
093A-035	Natural 60K				X									
	Natural 100K													
	Surface 60K/100K				X									
	Liquid 60K/100K					X								
093A-058	Natural 60K				X									
	Natural 100K													
	Surface 60K/100K				X									
	Liquid 60K/100K					X								
093B-024	Natural 60K				X									
	Natural 100K				X									
	Surface 60K/100K				X									
	Liquid 60K/100K					X								
093B-035	Natural 60K				X									
	Natural 100K				X									
	Surface 60K/100K				X									
	Liquid 60K/100K					X								
093B-058	Natural 60K					X								
	Natural 100K					X								
	Surface 60K/100K						X							
	Liquid 60K/100K							X						
093C-024	Natural 60K				X									
	Natural 100K					X								
	Surface 60K/100K					X								
	Liquid 60K/100K						X							
093C-035	Natural 60K				X									
	Natural 100K					X								
	Surface 60K/100K						X							
	Liquid 60K/100K						X							
093C-058	Natural 60K					X								
	Natural 100K					X								
	Surface 60K/100K							X						
	Liquid 60K/100K							X						
095A-024	Natural 60K				X									
	Natural 100K				X									
	Surface 60K/100K				X									
095A-035	Natural 60K				X									
	Natural 100K				X									
	Surface 60K/100K				X									
095A-058	Natural 60K				X									
	Natural 100K				X									
	Surface 60K/100K					X								

MHD motor	Mode of operation	INS0680,	INS0680,	INS0680,	INS0480,	INS0480,	INS0480,	INS0480,	INS0480,	INS0480,	INS0380,	INS0380,	INS0380,	INS0380,	INS0380,
		1,0mm ²	1,5mm ²	2,5mm ²	1,5mm ²	2,5mm ²	4,0mm ²	6,0mm ²	10,0mm ²	6,0mm ²	10,0mm ²	16,0mm ²	25,0mm ²	35,0mm ²	
095B-024	Natural 60K				X										
	Natural 100K				X										
	Surface 60K/100K				X										
095B-035	Natural 60K				X										
	Natural 100K				X										
	Surface 60K/100K				X										
095B-058	Natural 60K				X										
	Natural 100K					X									
	Surface 60K/100K						X								
095C-024	Natural 60K				X										
	Natural 100K				X										
	Surface 60K/100K				X										
095C-035	Natural 60K				X										
	Natural 100K					X									
	Surface 60K/100K						X								
095C-058	Natural 60K					X									
	Natural 100K					X									
	Surface 60K/100K						X								
112A-024	Natural 60K				X										
	Natural 100K														
	Surface 60K/100K				X										
112A-035	Natural 60K				X										
	Natural 100K														
	Surface 60K/100K				X										
112A-058	Natural 60K				X										
	Natural 100K														
	Surface 60K/100K					X									
112B-024	Natural 60K				X										
	Natural 100K					X									
	Surface 60K/100K						X								
112B-035	Natural 60K					X									
	Natural 100K														
	Surface 60K/100K							X							
112B-048	Natural 60K							X							
	Natural 100K								X						
	Surface 60K/100K									X					
112B-058	Natural 60K						X								
	Natural 100K							X							
	Surface 60K/100K								X						
112C-024	Natural 60K					X									
	Natural 100K						X								
	Surface 60K/100K							X							
112C-035	Natural 60K					X									
	Natural 100K						X								
	Surface 60K/100K								X						
112C-058	Natural 60K									X					
	Natural 100K										X				
	Surface 60K/100K											X			
112D-012	Natural 60K				X										
	Natural 100K														
	Surface 60K/100K					X									
112D-027	Natural 60K					X									
	Natural 100K						X								
	Surface 60K/100K							X							
115A-024	Natural 60K				X										
	Natural 100K					X									
	Surface 60K/100K						X								
	Liquid 60K/100K							X							
115A-035	Natural 60K					X									
	Natural 100K						X								
	Surface 60K/100K							X							
	Liquid 60K/100K								X						
115A-058	Natural 60K										X				
	Natural 100K										X				
	Surface 60K/100K											X			
	Liquid 60K/100K												X		

MHD motor	Mode of operation	INS0680,	INS0680,	INS0680,	INS0480,	INS0480,	INS0480,	INS0480,	INS0480,	INS0480,	INS0380,	INS0380,	INS0380,	INS0380,	INS0380,
		1,0mm ²	1,5mm ²	2,5mm ²	1,5mm ²	2,5mm ²	4,0mm ²	6,0mm ²	10,0mm ²	6,0mm ²	10,0mm ²	16,0mm ²	25,0mm ²	35,0mm ²	
115B-024	Natural 60K										X				
	Natural 100K										X				
	Surface 60K/100K										X				
	Liquid 60K/100K											X			
115B-035	Natural 60K										X				
	Natural 100K										X				
	Surface 60K/100K											X			
	Liquid 60K/100K												X		
115B-058	Natural 60K											X			
	Natural 100K											X			
	Surface 60K/100K												X		
	Liquid 60K/100K													X	
115C-024	Natural 60K										X				
	Natural 100K											X			
	Surface 60K/100K											X			
	Liquid 60K/100K												X		
115C-035	Natural 60K											X			
	Natural 100K											X			
	Surface 60K/100K												X		
	Liquid 60K/100K													X	
115C-058	Natural 60K												X		
	Natural 100K													X	
	Surface 60K/100K														X
	Liquid 60K/100K														X
131B-024	Natural 60K										X				
	Natural 100K														
	Surface 60K/100K													X	
131D-024	Natural 60K												X		
	Natural 100K														
	Surface 60K/100K													X	

Fig. 20-3: Overview of power connector cross-sections

INS0680, 1.0mm²

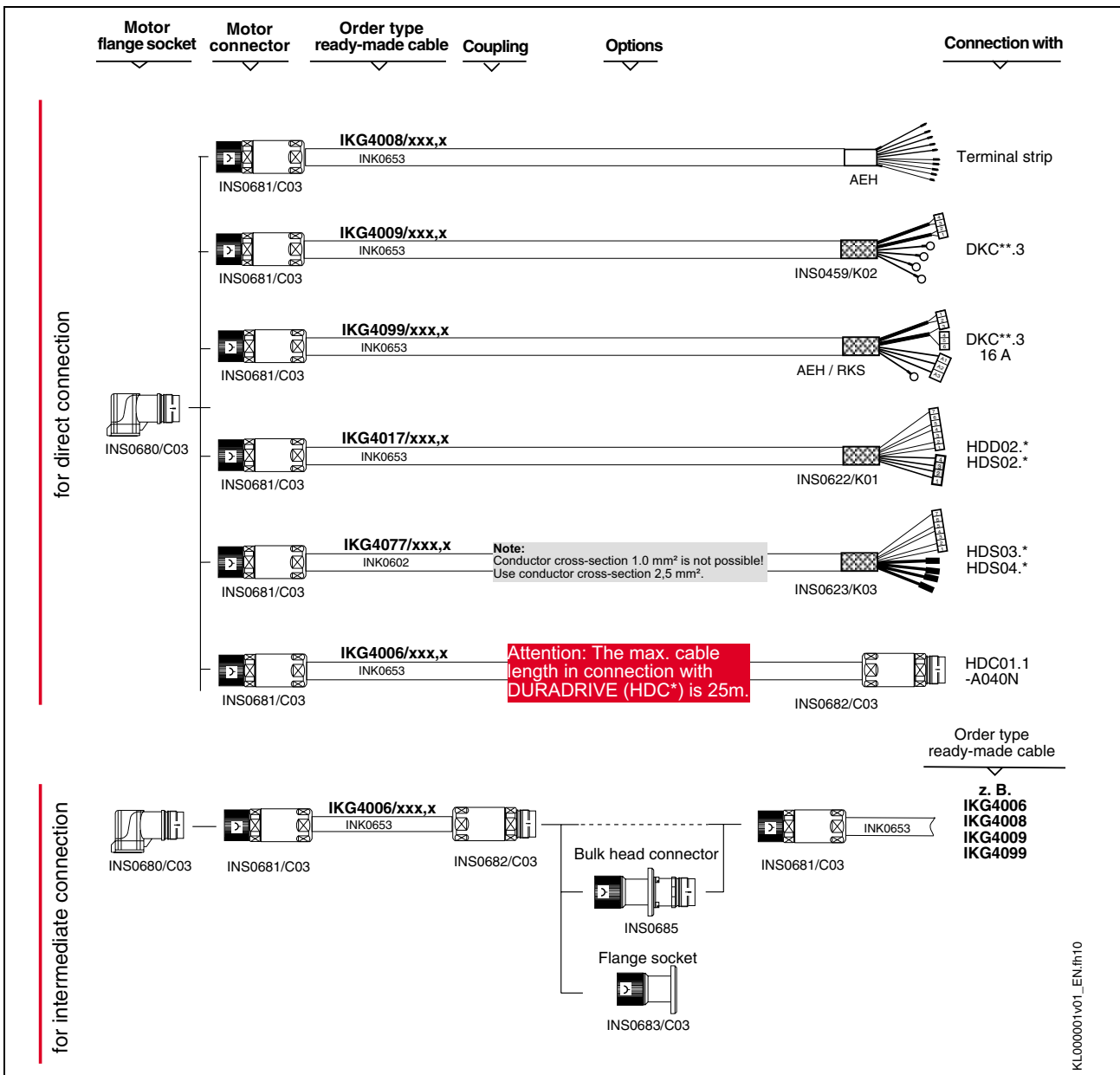
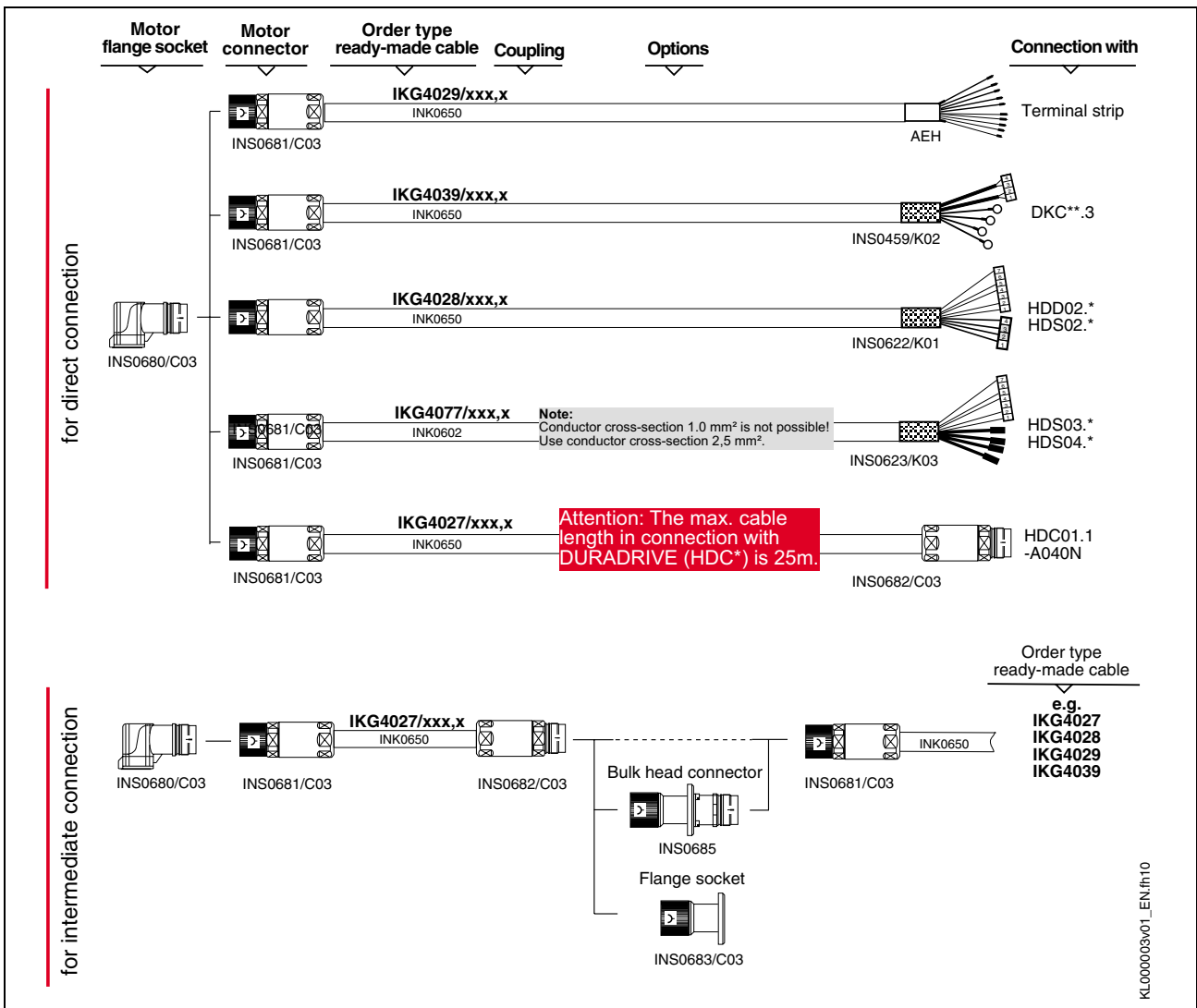

Fig. 20-4: Cable selection INS0680 -1.0mm²

KL000001w01_EN.fh10

INS0680, 1.5mm²



KL000003v01_EN.fm10

Fig. 20-5: Cable selection INS0680 -1.5mm²

INS0680, 2.5mm²

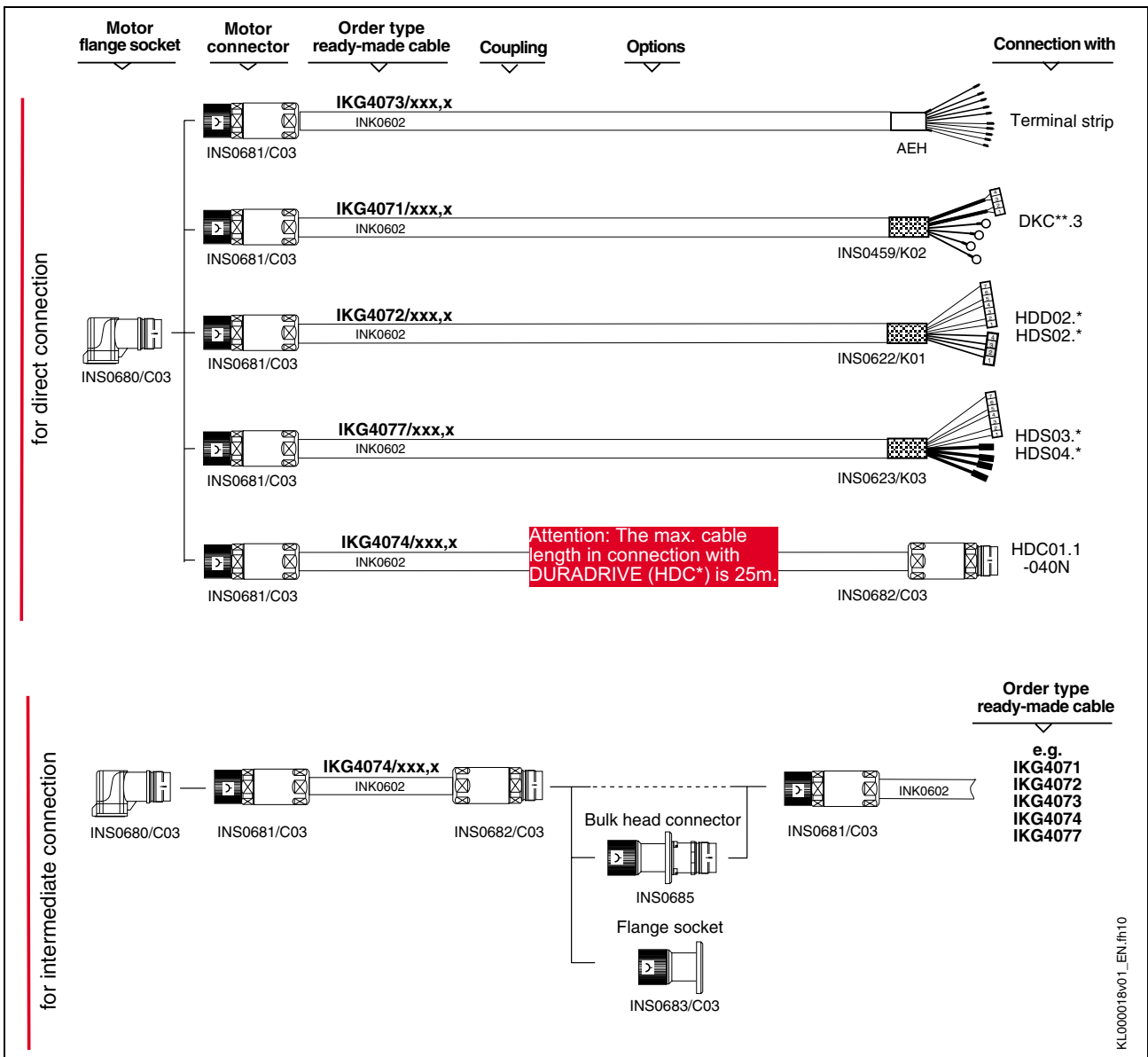

Fig. 20-6 Cable selection INS0680 -2.5mm²

KL000018v01_EN.fh10

INS0480, 1.5mm²

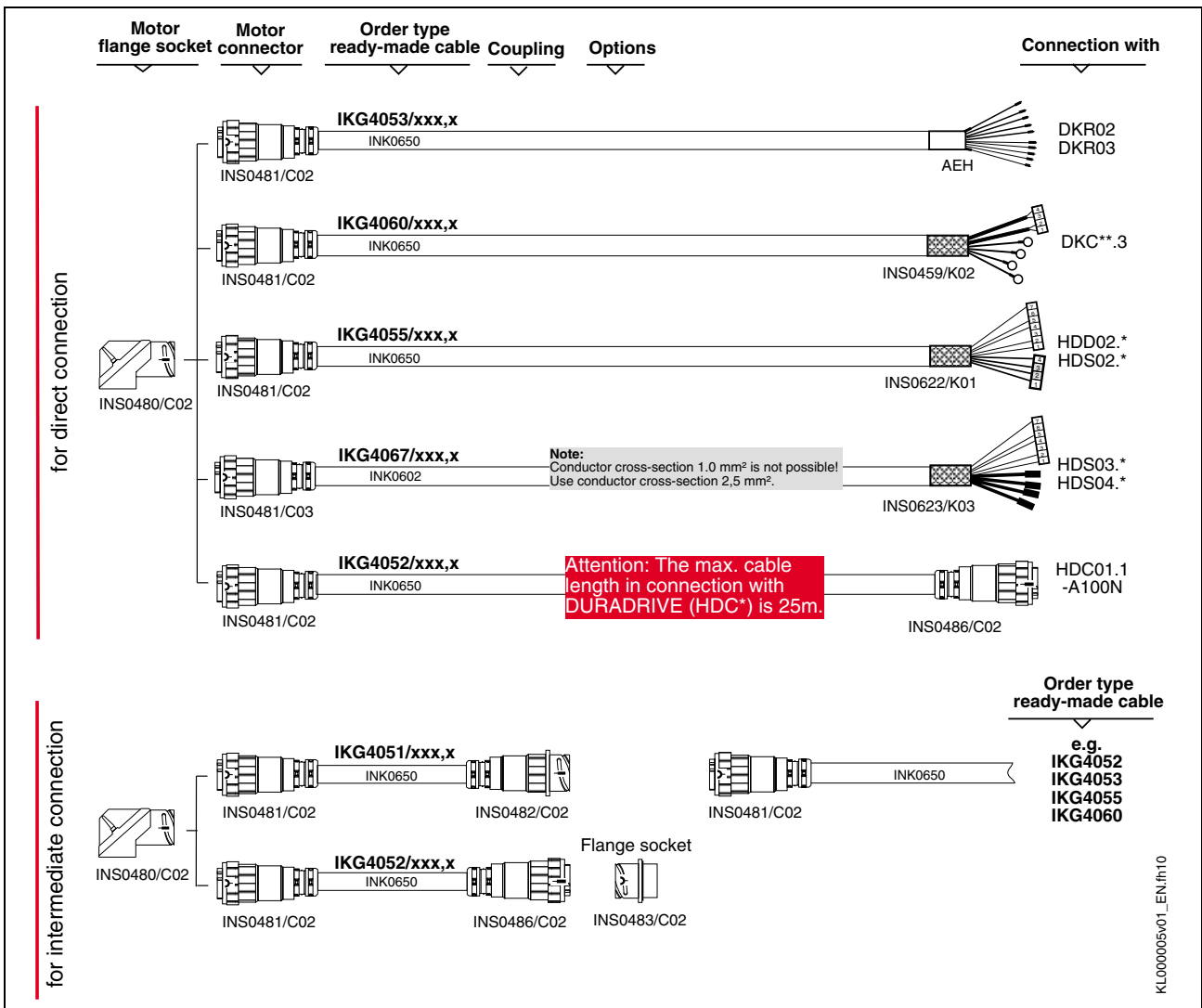

Fig. 20-7: Cable selection INS0480 -1.5mm²

KL000005v01_EN.fh10

INS0480, 2.5mm²

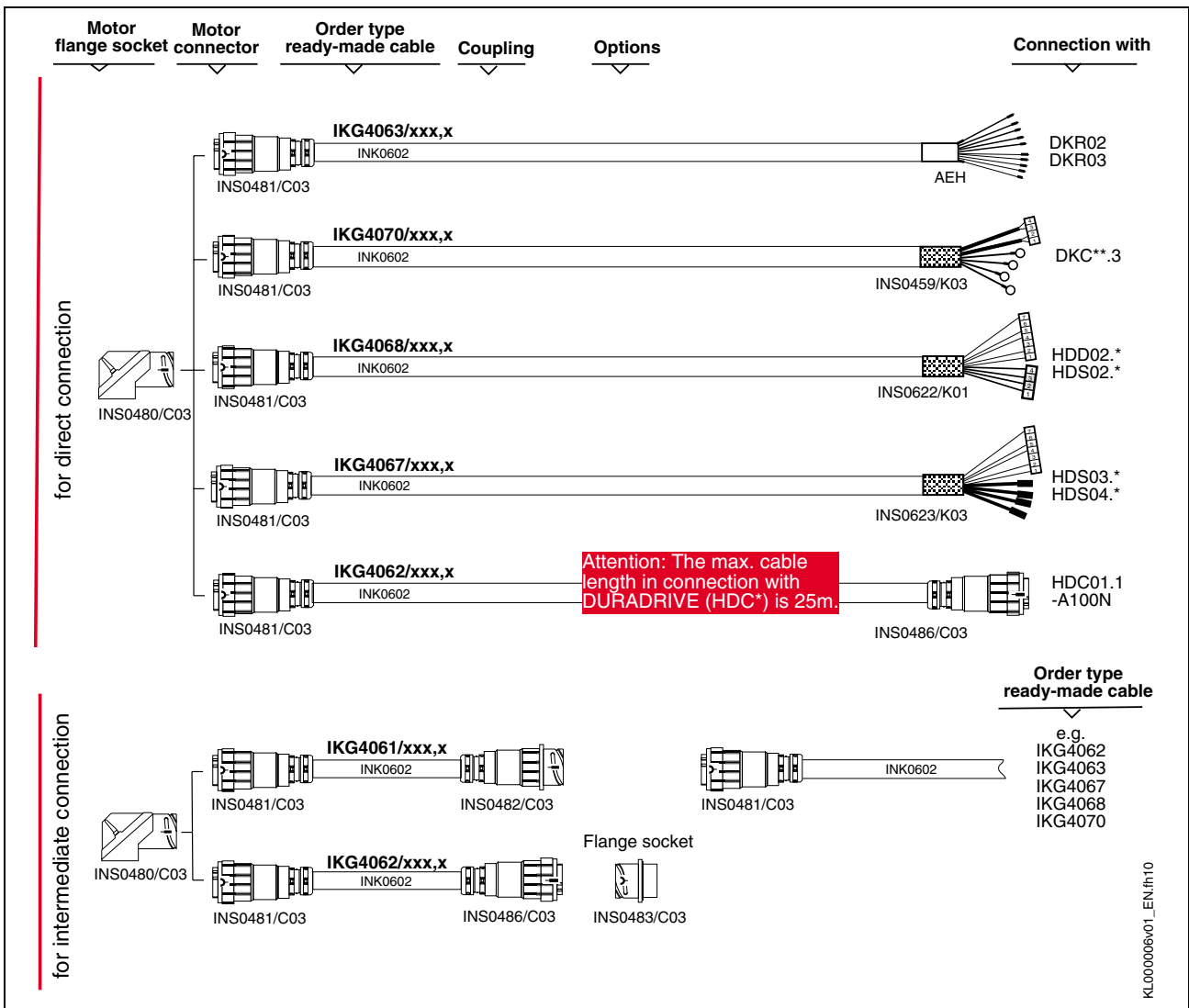

Fig. 20-8: Cable selection INS0480 -2.5mm²

KL000006v01_EN.fth10

INS0480, 4.0mm²

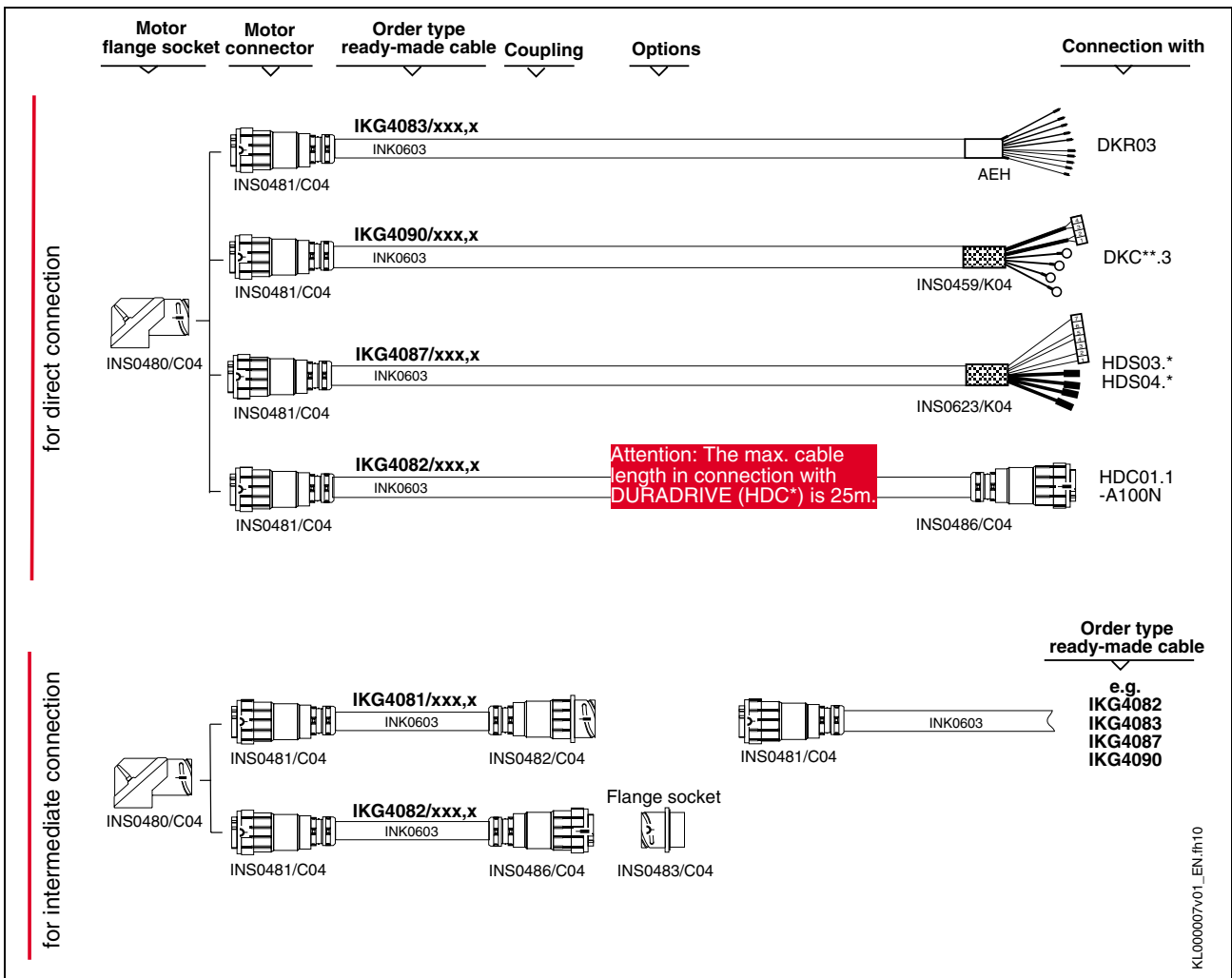

Fig. 20-9: Cable selection INS0480 -4.0mm²

INS0480, 6.0mm²

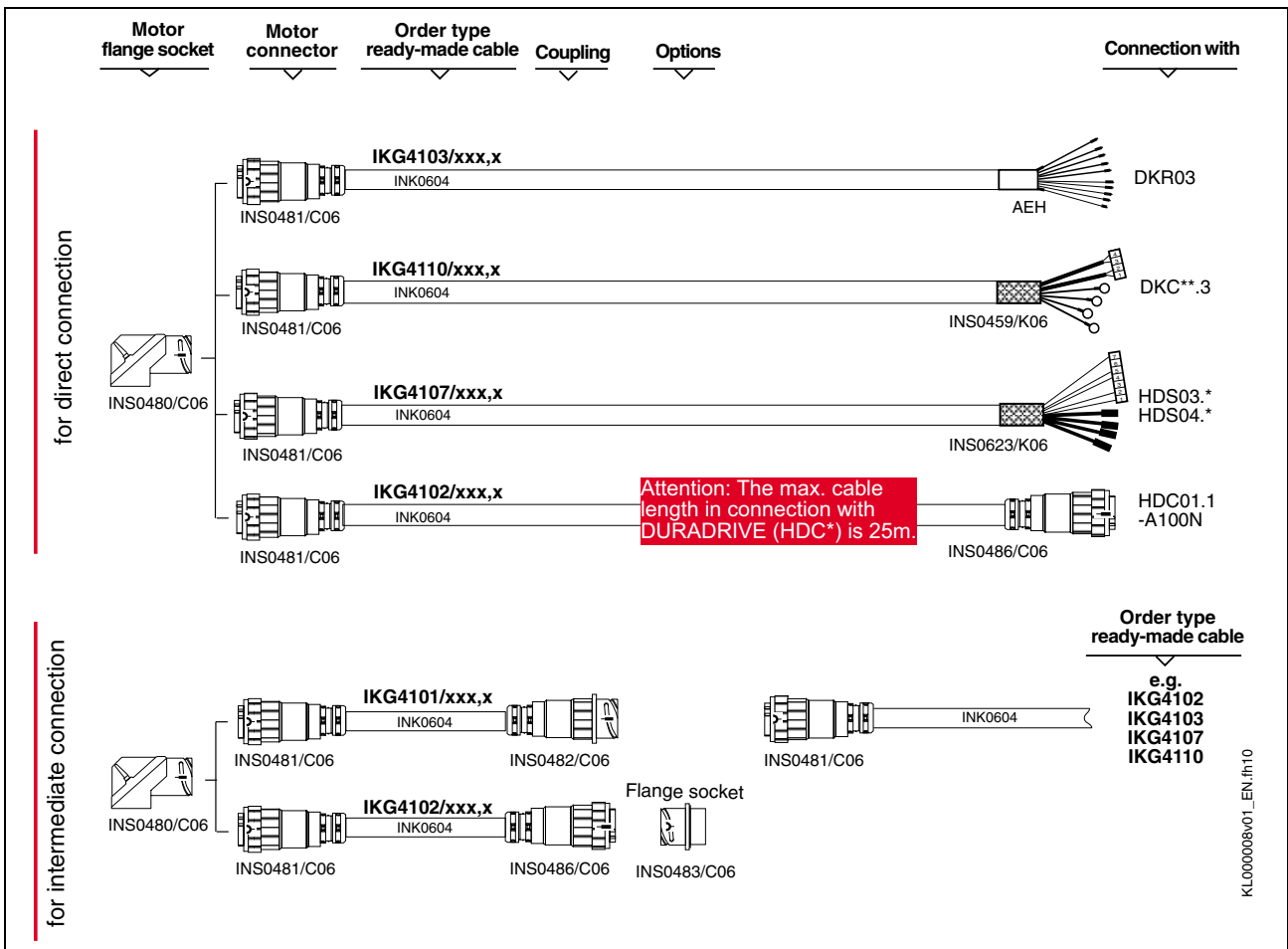

Fig. 20-10: Cable selection INS0480 -6.0mm²

KL00008v01_EN.fm.10

INS0480, 10.0mm²

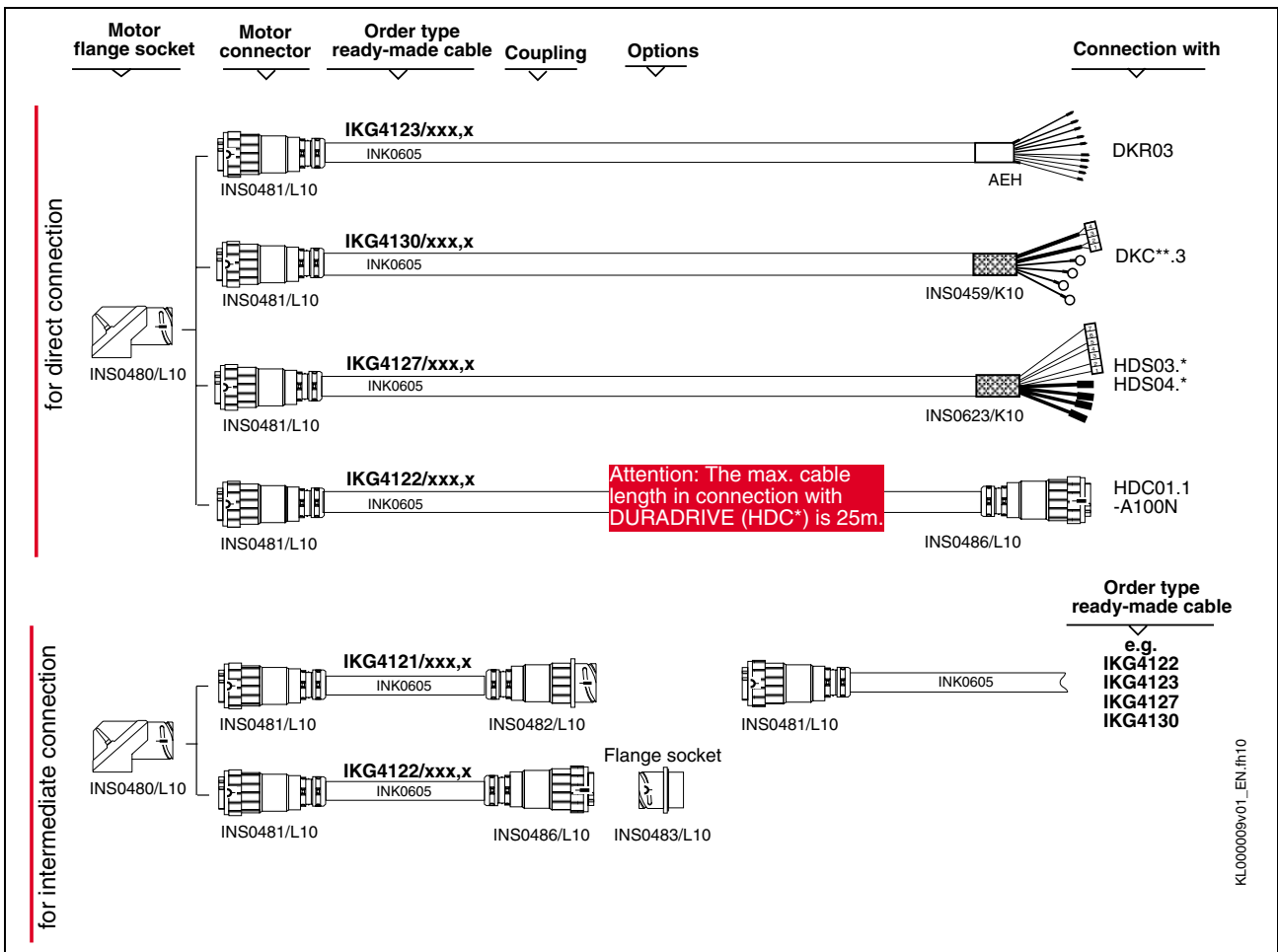

Fig. 20-11: Cable selection INS0480 -10.0mm²

INS0380, 6.0mm²

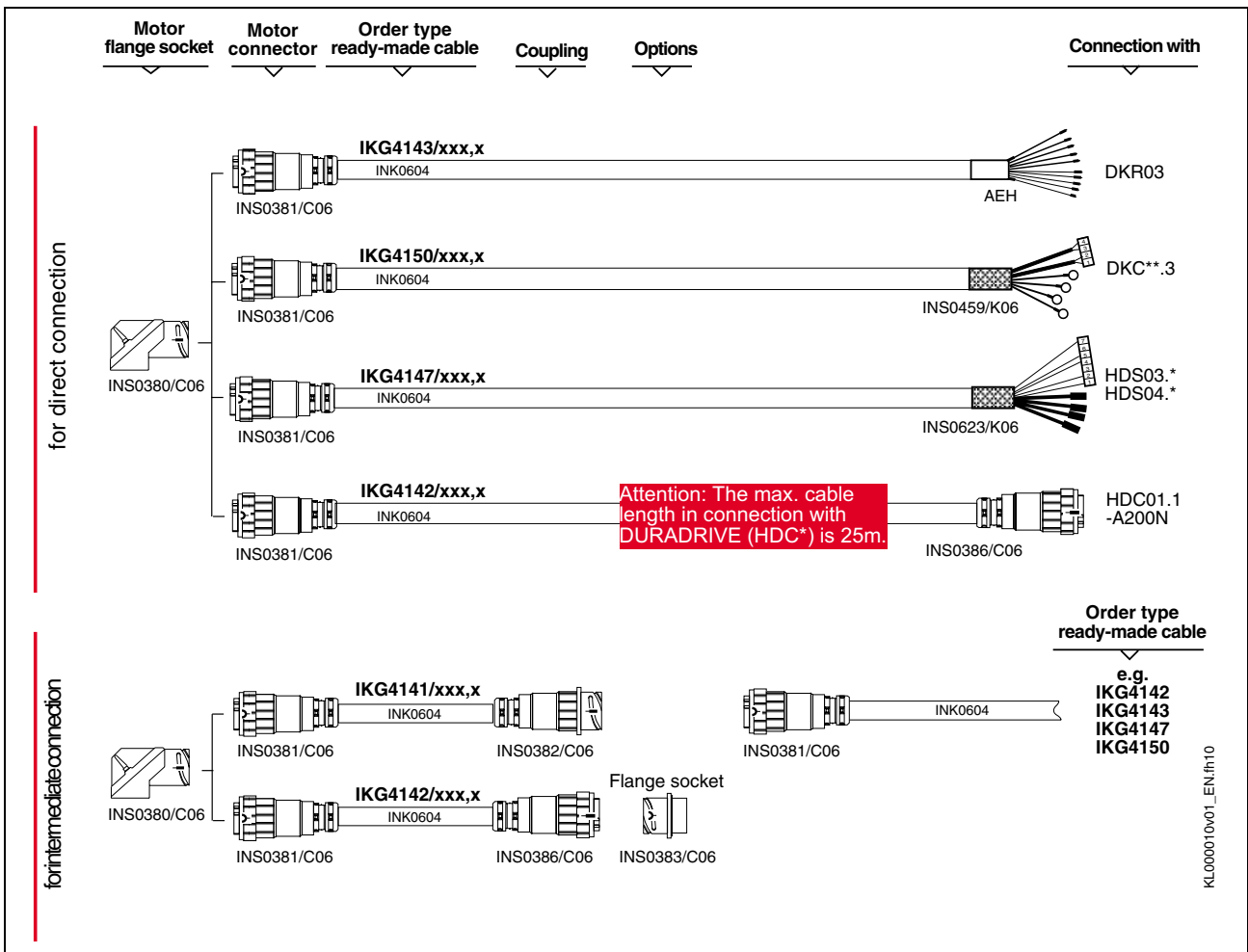

Fig. 20-12: Cable selection INS0380 -6.0mm²

INS0380, 10.0mm²

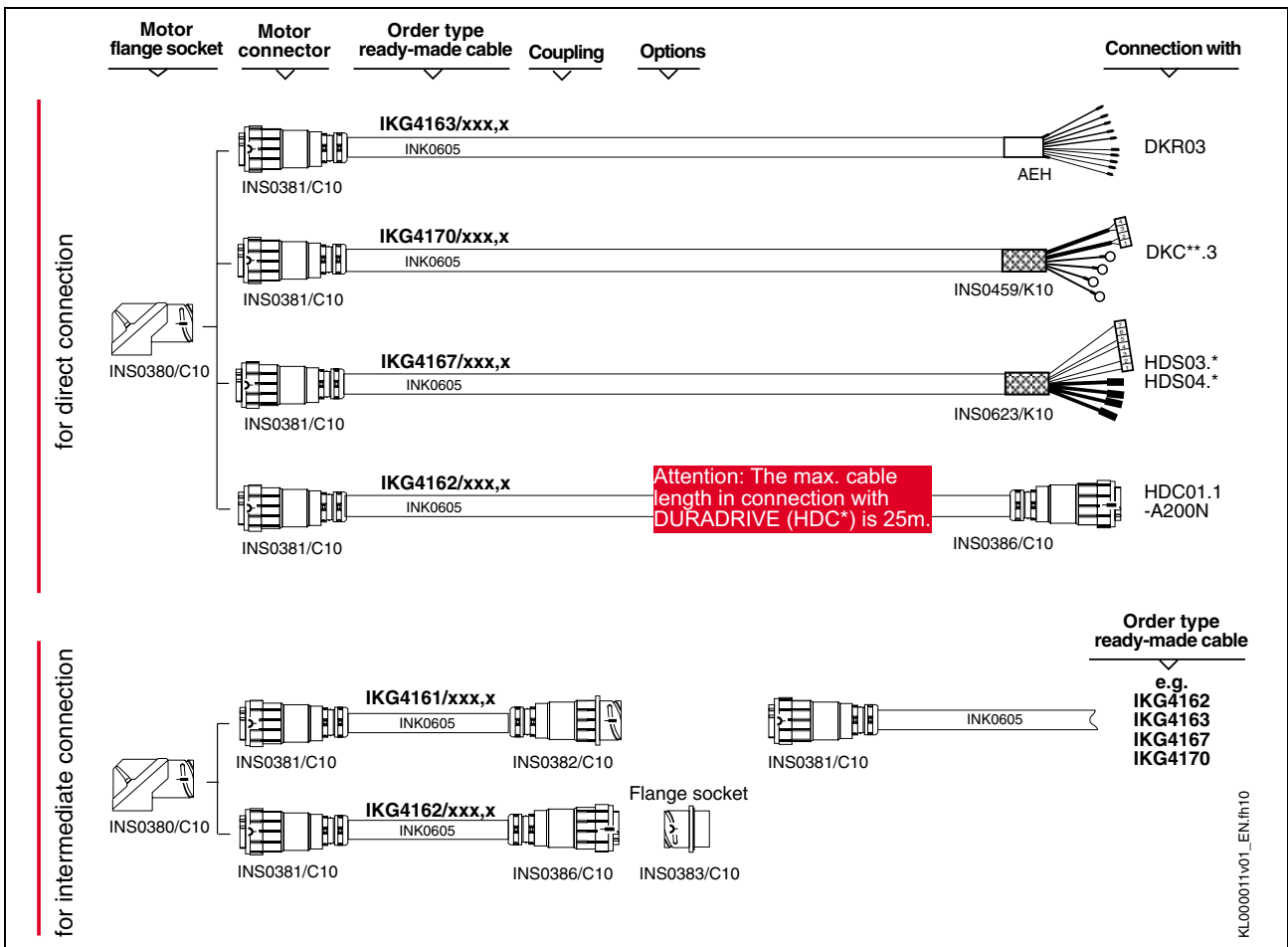

Fig. 20-13: Cable selection INS0380 -10.0mm²

INS0380, 16.0mm²

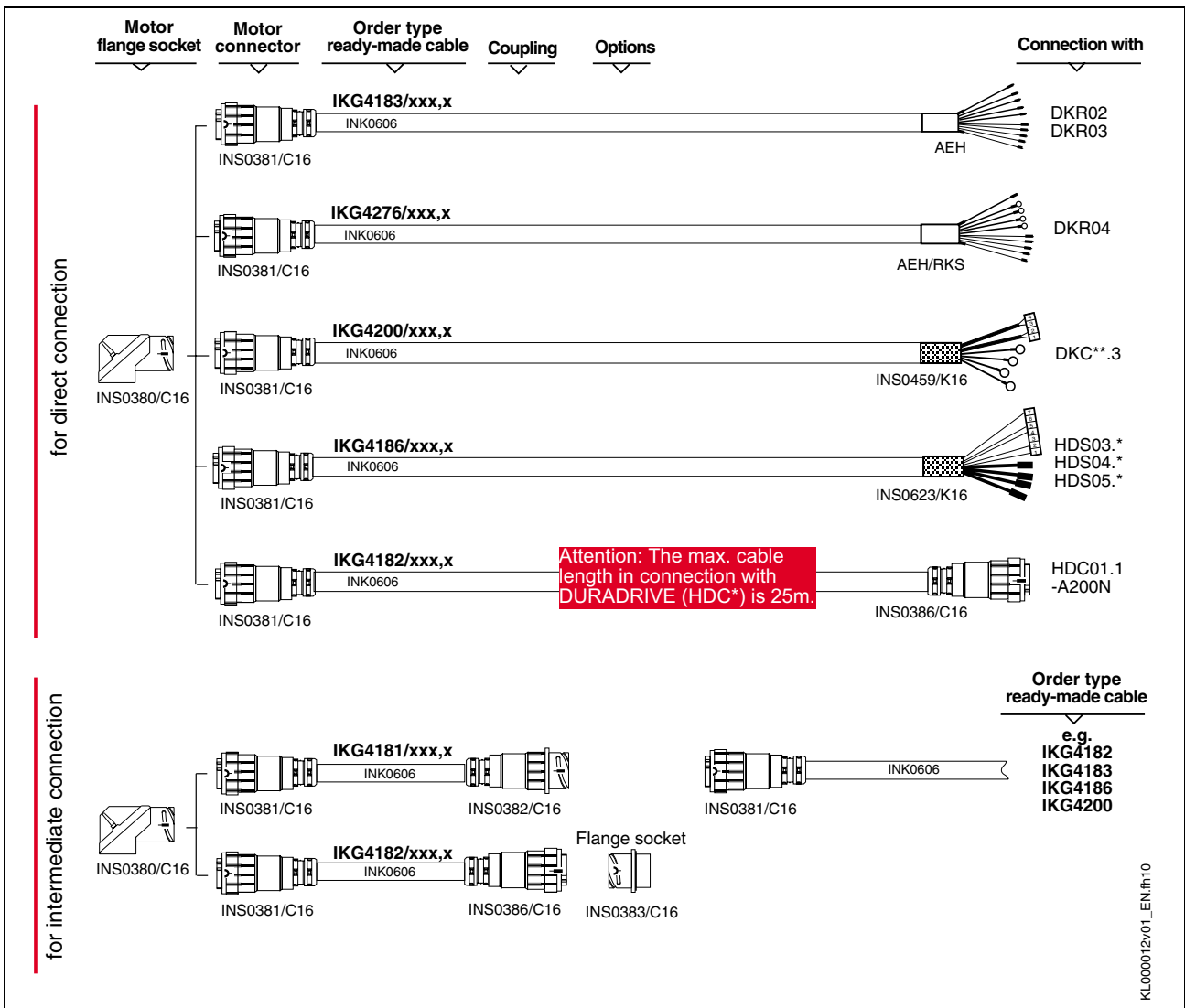

Fig. 20-14: Cable selection INS0380 -16.0mm²

INS0380, 25.0mm²

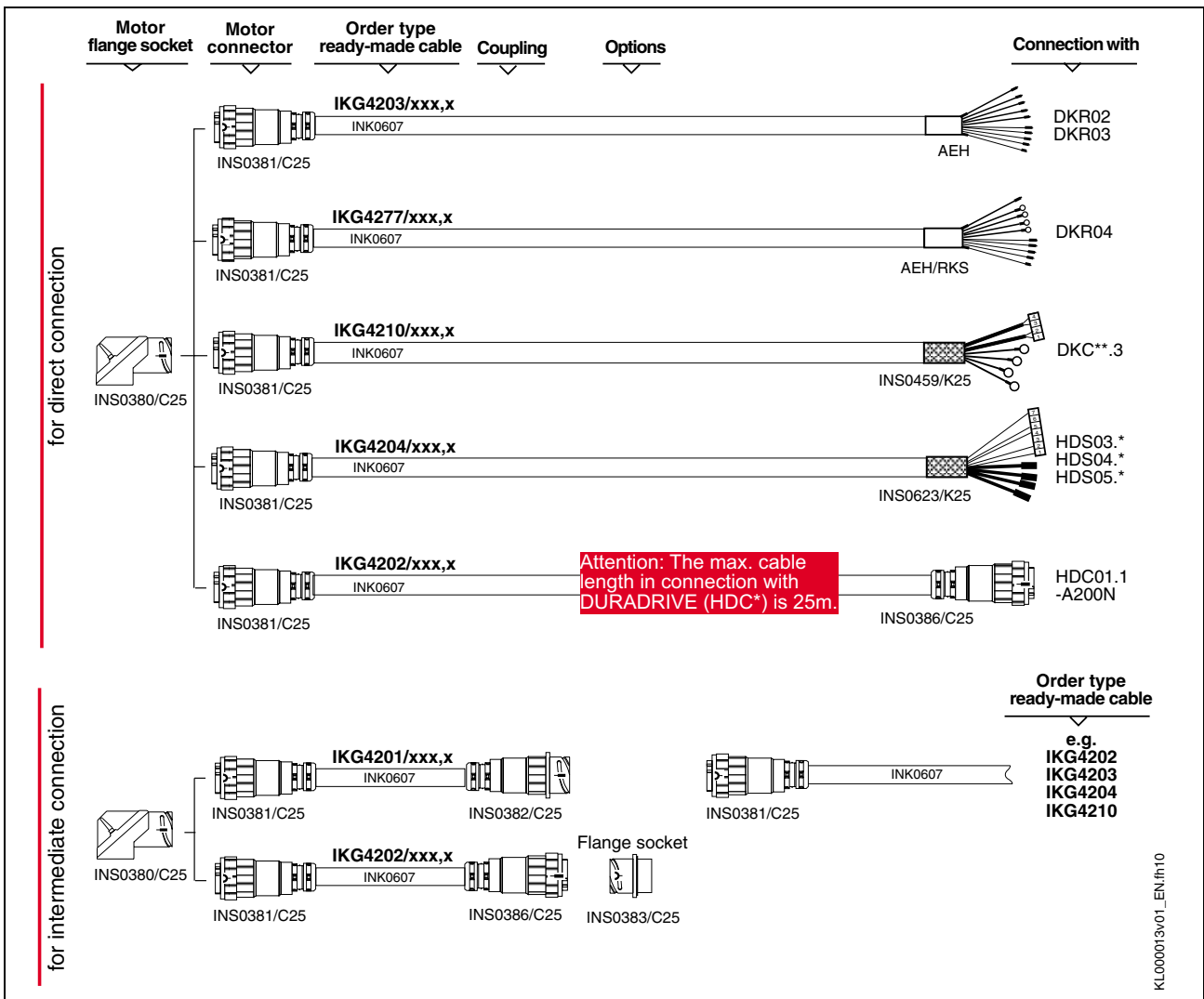

Fig. 20-15: Cable selection INS0380 -25.0mm²

INS0380, 35.0mm²

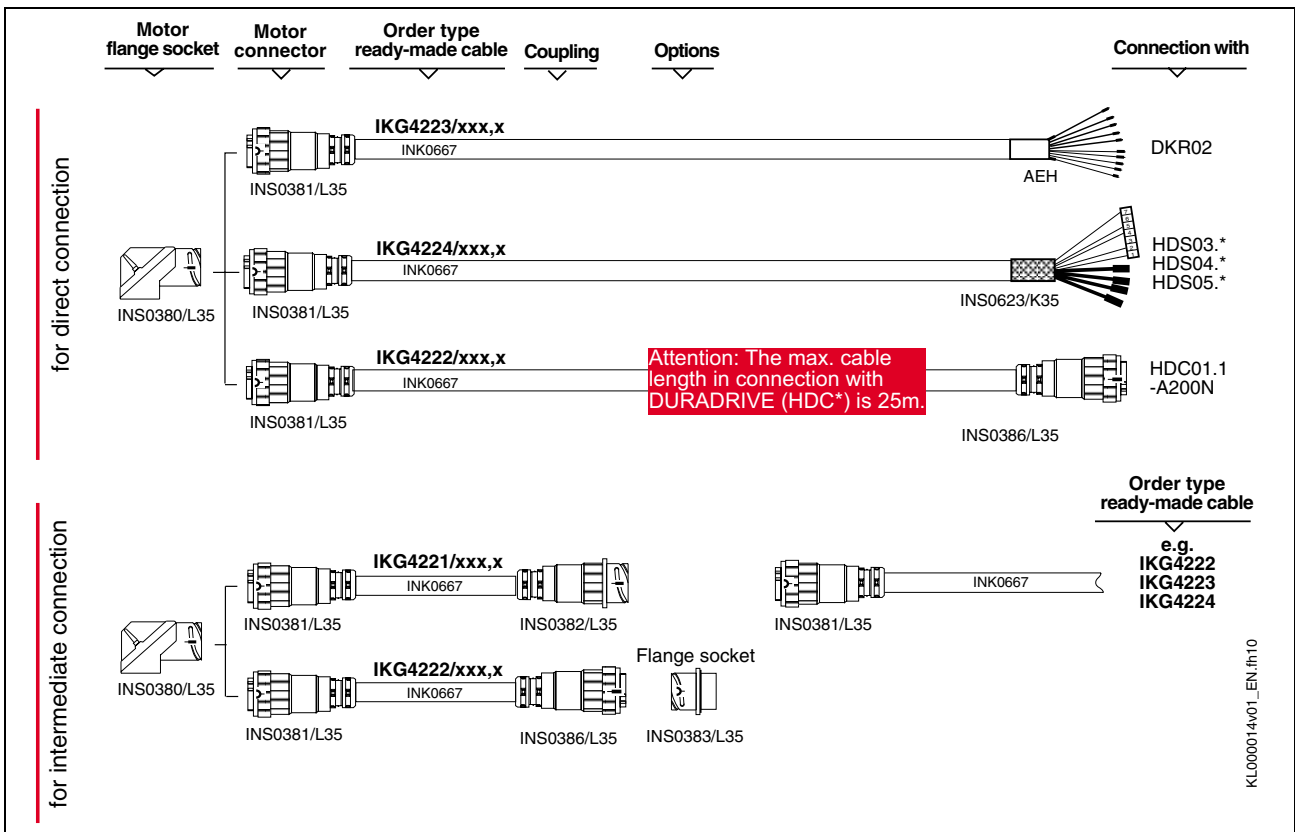

Fig. 20-16: Cable selection INS0380 -35.0mm²

20.3 Selecting Encoder Cables

Encoder cables in “straight” and “angular” design are available for MHD motors. Refer to the diagrams below.

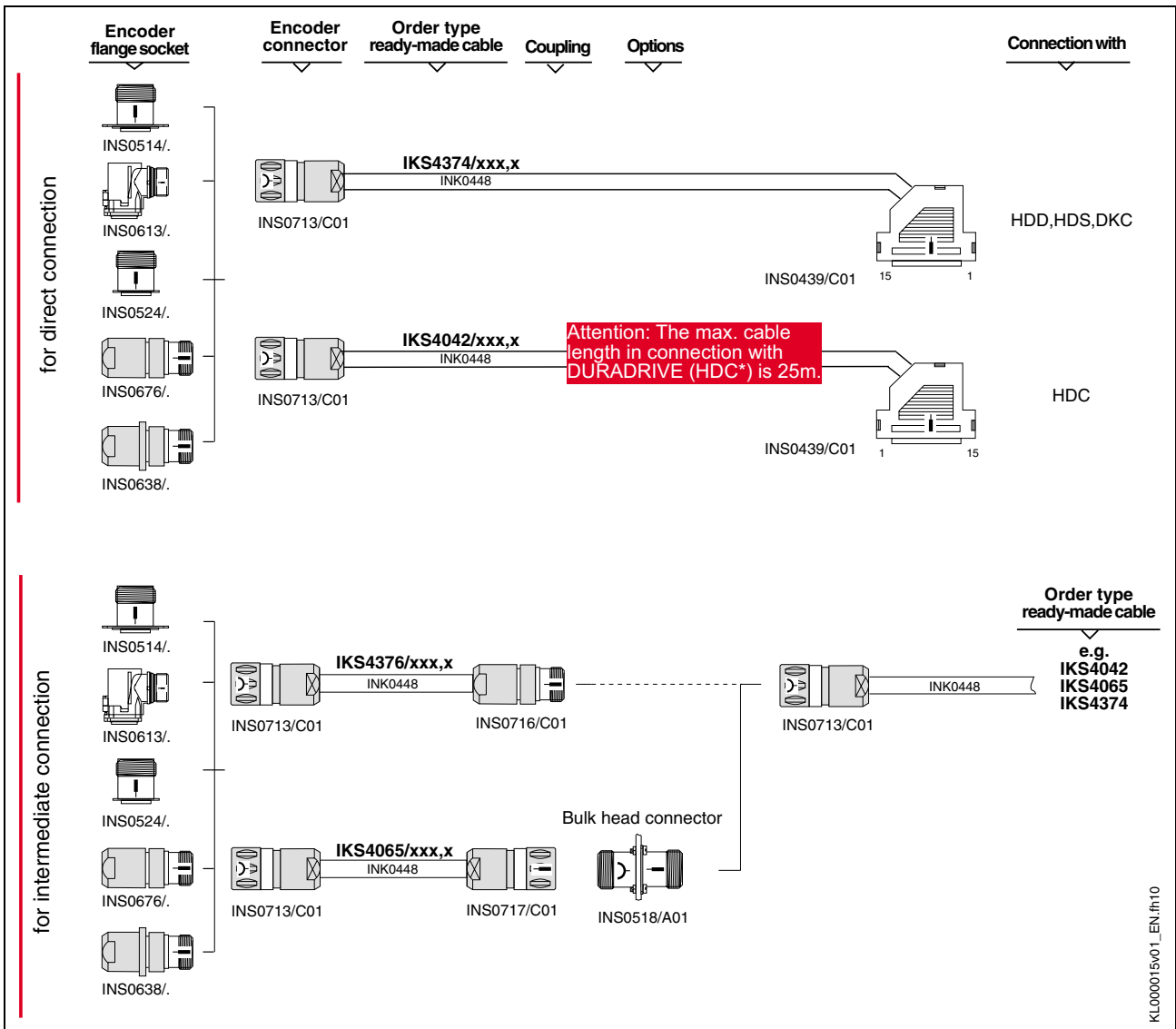

Fig. 20-17: Straight encoder cable

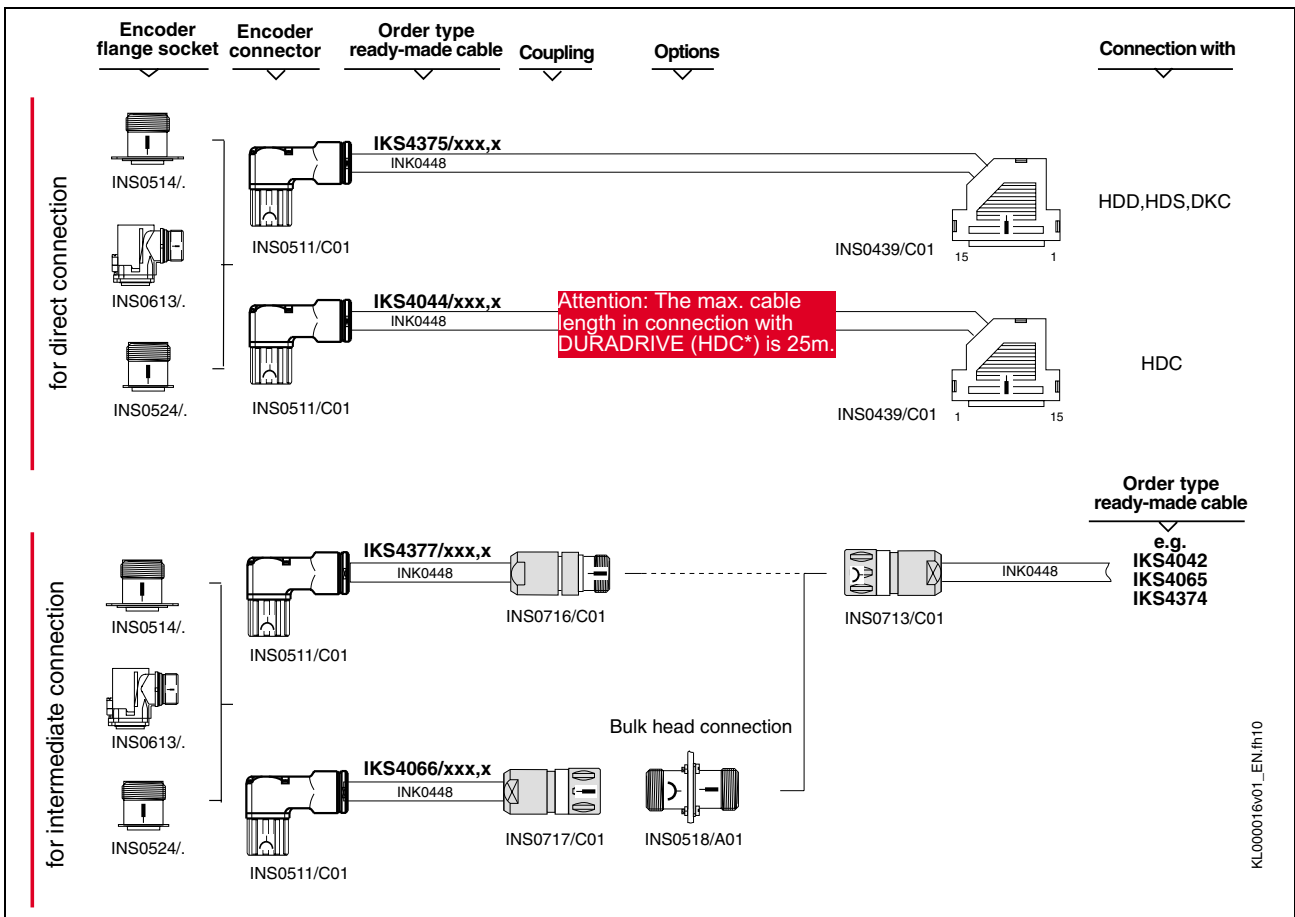

Fig. 20-18: : Angular encoder cable

21 Index

A

Assembly 18-1

C

Characteristic motor speed 5-3
Characteristic voltage limit curves 5-5
commutation 1-2
Commutation 1-2
Components 1-2
Connection lines 19-2
Continuous current at standstill 5-3
Continuous torque at standstill 1-1, 5-3
Coolant lines 16-10
Cooling ribs 19-2
Cooling system components 16-9
Cycle duration 5-2
Cyclic duration factor 5-2

D

Degree of protection 16-3
Design 1-2
Designs 1-2
Drag chains 19-2
Dynamics 1-2

E

Encoder system 4-3
Energy management chains 19-2

F

Featherkey 16-14

H

Heat dissipation 19-2
Holding brake 4-4, 19-3
 electrically clamping 16-12
 electrically releasing 16-12
 Note regarding danger 16-11
Housing overtemperature 5-1
Housing temperature 5-1
Housing type 4-5

I

Identification 17-1
Idle time 5-2
Intended use
 Fields of application 2-2
 Introduction 2-1
 Requirements 2-1

K

Keyway 4-3, 16-14
Keyway length 16-14

L

Lifting sling belts 17-3
Liquid cooling 16-9
Locking screws 18-2

M

Machine accuracy 5-1
Maintenance-free operation 1-1
Mass 5-4
Maximum speed 5-4
Moment of inertia of the rotor 5-4
Motor encoder 4-3
Motor frame length 4-2
Motor frame size 4-2

N

Non-intended use 2-2
 Consequences, disclaimer of liability 2-1
Number of pole pairs 5-3

O

ON time 5-2
Operating modes 5-2
Operational reliability 1-1
Output direction 4-4
Output shaft 4-3
 Plain shaft 4-3
Outside systems 1-5
Overload capability 1-2
Overload protection 1-2

P

Packing 17-2
Peak current 5-3
Performance data 1-2
Plain shaft 16-14
Power connector 18-5
Pressure drop 16-10
Product group 4-2

R

Radial shaft sealing ring 5-1
Rated current 5-3
Rated frequency 5-3
Rated output 5-3
Rated speed 5-3
Rated torque 5-3
Rated voltage 5-3
Recommended grinding-in procedure 19-3
Redundant bearing 16-17
Running noise 19-2

S

Safety Instructions for Electric Drives and Controls 3-1
Shaft sealing ring 16-15
Shock absorption 17-3
Skilled technical personnel 18-1
Standards 1-5
Startup 19-1
System circuit diagram 18-3

T

Theoretical maximum torque 5-4
Thermal limit curves 5-5
Thermal time constant 5-4
Tightness 16-15
Torque constant 5-3
Type code 4-1

U

Use *Siehe bestimmungsgemäßer Gebrauch und siehe nicht-bestimmungsgemäßer Gebrauch*

V

Vibrations, sinusoidal 16-2
Voltage constant 5-3

W

Winding code 4-3
Winding inductivity 5-3
Winding overtemperature 5-1
Winding resistance 5-3
winding temperature 5-1

22 Service & Support

22.1 Helpdesk

Unser Kundendienst-Helpdesk im Hauptwerk Lohr am Main steht Ihnen mit Rat und Tat zur Seite. Sie erreichen uns

Our service helpdesk at our headquarters in Lohr am Main, Germany can assist you in all kinds of inquiries. Contact us

- telefonisch - by phone:
über Service Call Entry Center
- via Service Call Entry Center
- per Fax - by fax:
- per e-Mail - by e-mail: service.svc@boschrexroth.de

49 (0) 9352 40 50 60

Mo-Fr 07:00-18:00
Mo-Fr 7:00 am - 6:00 pm

+49 (0) 9352 40 49 41

22.2 Service-Hotline

Außerhalb der Helpdesk-Zeiten ist der Service direkt ansprechbar unter

After helpdesk hours, contact our service department directly at

+49 (0) 171 333 88 26

oder - or

+49 (0) 172 660 04 06

22.3 Internet

Unter www.boschrexroth.com finden Sie ergänzende Hinweise zu Service, Reparatur und Training sowie die **aktuellen** Adressen *) unserer auf den folgenden Seiten aufgeführten Vertriebs- und Servicebüros.



Verkaufsniederlassungen



Niederlassungen mit Kundendienst

Außerhalb Deutschlands nehmen Sie bitte zuerst Kontakt mit unserem für Sie nächstgelegenen Ansprechpartner auf.

*) Die Angaben in der vorliegenden Dokumentation können seit Drucklegung überholt sein.

At www.boschrexroth.com you may find additional notes about service, repairs and training in the Internet, as well as the **actual** addresses *) of our sales- and service facilities figuring on the following pages.



sales agencies



offices providing service

Please contact our sales / service office in your area first.

*) Data in the present documentation may have become obsolete since printing.

22.4 Vor der Kontaktaufnahme... - Before contacting us...

Wir können Ihnen schnell und effizient helfen wenn Sie folgende Informationen bereithalten:

1. detaillierte Beschreibung der Störung und der Umstände.
2. Angaben auf dem Typenschild der betreffenden Produkte, insbesondere Typenschlüssel und Seriennummern.
3. Tel./Faxnummern und e-Mail-Adresse, unter denen Sie für Rückfragen zu erreichen sind.

For quick and efficient help, please have the following information ready:

1. Detailed description of the failure and circumstances.
2. Information on the type plate of the affected products, especially type codes and serial numbers.
3. Your phone/fax numbers and e-mail address, so we can contact you in case of questions.

22.5 Kundenbetreuungsstellen - Sales & Service Facilities

Deutschland – Germany

vom Ausland:

(0) nach Landeskennziffer weglassen!

from abroad:

don't dial (0) after country code!

Vertriebsgebiet Mitte Germany Centre	SERVICE	SERVICE	SERVICE
Bosch Rexroth AG Bgm.-Dr.-Nebel-Str. 2 / Postf. 1357 97816 Lohr am Main / 97803 Lohr Kompetenz-Zentrum Europa Tel.: +49 (0)9352 40-0 Fax: +49 (0)9352 40-4885	CALL ENTRY CENTER MO – FR von 07:00 - 18:00 Uhr from 7 am – 6 pm Tel. +49 (0) 9352 40 50 60 service.svc@boschrexroth.de	HOTLINE MO – FR von 17:00 - 07:00 Uhr from 5 pm - 7 am + SA / SO Tel.: +49 (0)172 660 04 06 oder / or Tel.: +49 (0)171 333 88 26	ERSATZTEILE / SPARES verlängerte Ansprechzeit - extended office time - ♦ nur an Werktagen - only on working days - ♦ von 07:00 - 18:00 Uhr - from 7 am - 6 pm - Tel. +49 (0) 9352 40 42 22
Vertriebsgebiet Süd Germany South Bosch Rexroth AG Landshuter Allee 8-10 80637 München Tel.: +49 (0)89 127 14-0 Fax: +49 (0)89 127 14-490	Vertriebsgebiet West Germany West Bosch Rexroth AG Regionalzentrum West Borsigstrasse 15 40880 Ratingen Tel.: +49 (0)2102 409-0 Fax: +49 (0)2102 409-406 +49 (0)2102 409-430	Gebiet Südwest Germany South-West Bosch Rexroth AG Service-Regionalzentrum Süd-West Siemensstr.1 70736 Fellbach Tel.: +49 (0)711 51046-0 Fax: +49 (0)711 51046-248	
Vertriebsgebiet Nord Germany North Bosch Rexroth AG Walsroder Str. 93 30853 Langenhagen Tel.: +49 (0) 511 72 66 57-0 Service: +49 (0) 511 72 66 57-256 Fax: +49 (0) 511 72 66 57-93 Service: +49 (0) 511 72 66 57-95	Vertriebsgebiet Mitte Germany Centre Bosch Rexroth AG Regionalzentrum Mitte Waldecker Straße 13 64546 Mörfelden-Walldorf Tel.: +49 (0) 61 05 702-3 Fax: +49 (0) 61 05 702-444	Vertriebsgebiet Ost Germany East Bosch Rexroth AG Beckerstraße 31 09120 Chemnitz Tel.: +49 (0)371 35 55-0 Fax: +49 (0)371 35 55-333	Vertriebsgebiet Ost Germany East Bosch Rexroth AG Regionalzentrum Ost Walter-Köhn-Str. 4d 04356 Leipzig Tel.: +49 (0)341 25 61-0 Fax: +49 (0)341 25 61-111

Europa (West) - Europe (West)

vom Ausland: (0) nach Landeskennziffer weglassen, **Italien:** 0 nach Landeskennziffer mitwählen
from abroad: don't dial (0) after country code, **Italy:** dial 0 after country code

Austria - Österreich Bosch Rexroth GmbH Electric Drives & Controls Tel.: +43 (0)1 985 25 40 Fax: +43 (0)1 985 25 40-93	Austria – Österreich Bosch Rexroth GmbH Electric Drives & Controls Industriepark 18 4061 Pasching Tel.: +43 (0)7221 605-0 Fax: +43 (0)7221 605-21	Belgium - Belgien Bosch Rexroth AG Electric Drives & Controls Industrielaan 8 1740 Ternat Tel.: +32 (0)2 5830719 - service: +32 (0)2 5830717 Fax: +32 (0)2 5830731 service@boschrexroth.be	Denmark - Dänemark BEC A/S Zinkvej 6 8900 Randers Tel.: +45 (0)87 11 90 60 Fax: +45 (0)87 11 90 61
Great Britain – Großbritannien Bosch Rexroth Ltd. Electric Drives & Controls Broadway Lane, South Cerney Cirencester, Glos GL7 5UH Tel.: +44 (0)1285 863000 Fax: +44 (0)1285 863030 sales@boschrexroth.co.uk service@boschrexroth.co.uk	Finland - Finnland Bosch Rexroth Oy Electric Drives & Controls Ansatie 6 017 40 Vantaa Tel.: +358 (0)9 84 91-11 Fax: +358 (0)9 84 91-13 60	France - Frankreich Bosch Rexroth SAS Electric Drives & Controls Avenue de la Trentaine (BP. 74) 77503 Chelles Cedex Tel.: +33 (0)164 72-70 00 Fax: +33 (0)164 72-63 00 Hotline: +33 (0)608 33 43 28	France - Frankreich Bosch Rexroth SAS Electric Drives & Controls ZI de Thibaud, 20 bd. Thibaud (BP. 1751) 31084 Toulouse Tel.: +33 (0)5 61 43 61 87 Fax: +33 (0)5 61 43 94 12
France – Frankreich Bosch Rexroth SAS Electric Drives & Controls 91, Bd. Irène Joliot-Curie 69634 Vénissieux – Cedex Tel.: +33 (0)4 78 78 53 65 Fax: +33 (0)4 78 78 53 62	Italy - Italien Bosch Rexroth S.p.A. Via G. Di Vittoria, 1 20063 Cernusco S/N.MI Tel.: +39 02 92 365 1 +39 02 92 365 326 Fax: +39 02 92 365 500 +39 02 92 365 516378	Italy - Italien Bosch Rexroth S.p.A. Via Paolo Veronesi, 250 10148 Torino Tel.: +39 011 224 88 11 Fax: +39 011 224 88 30	Italy - Italien Bosch Rexroth S.p.A. Via del Progresso, 16 (Zona Ind.) 35020 Padova Tel.: +39 049 8 70 13 70 Fax: +39 049 8 70 13 77
Italy - Italien Bosch Rexroth S.p.A. Via Mascia, 1 80053 Castellammare di Stabia NA Tel.: +39 081 8 71 57 00 Fax: +39 081 8 71 68 85	Italy - Italien Bosch Rexroth S.p.A. Viale Oriani, 38/A 40137 Bologna Tel.: +39 051 34 14 14 Fax: +39 051 34 14 22	Netherlands – Niederlande/Holland Bosch Rexroth B.V. Kruisbroeksestraat 1 (P.O. Box 32) 5281 RV Boxtel Tel.: +31 (0)411 65 19 51 Fax: +31 (0)411 65 14 83 www.boschrexroth.nl	Netherlands - Niederlande/Holland Bosch Rexroth Services B.V. Technical Services Kruisbroeksestraat 1 (P.O. Box 32) 5281 RV Boxtel Tel.: +31 (0)411 65 19 51 Fax: +31 (0)411 67 78 14 services@boschrexroth.nl
Norway - Norwegen Bosch Rexroth AS Electric Drives & Controls Berghagan 1 or: Box 3007 1405 Ski-Langhus 1402 Ski Tel.: +47 (0)64 86 41 00 Fax: +47 (0)64 86 90 62 jul.ruud@rexroth.no	Spain - Spanien Bosch Rexroth S.A. Electric Drives & Controls Centro Industrial Santiga Obradors s/n 08130 Santa Perpetua de Mogoda Barcelona Tel.: +34 9 37 47 94 00 Fax: +34 9 37 47 94 01	Spain – Spanien Goimendi S.A. Electric Drives & Controls Parque Empresarial Zuatzu C/ Francisco Grandmontagne no.2 20018 San Sebastian Tel.: +34 9 43 31 84 21 - service: +34 9 43 31 84 56 Fax: +34 9 43 31 84 27 - service: +34 9 43 31 84 60 sat.indramat@goimendi.es	Sweden - Schweden Rexroth Mecman Svenska AB Electric Drives & Controls - Varuvägen 7 (Service: Konsumentvägen 4, Älfsjö) 125 81 Stockholm Tel.: +46 (0)8 727 92 00 Fax: +46 (0)8 647 32 77
Sweden - Schweden Rexroth Mecman Svenska AB Electric Drives & Controls Ekvändan 7 254 67 Helsingborg Tel.: +46 (0) 42 38 88 -50 Fax: +46 (0) 42 38 88 -74	Switzerland West - Schweiz West Bosch Rexroth Suisse SA Electric Drives & Controls Rue du village 1 1020 Renens Tel.: +41 (0)21 632 84 20 Fax: +41 (0)21 632 84 21	Switzerland East - Schweiz Ost Bosch Rexroth Schweiz AG Electric Drives & Controls Hemrietstrasse 2 8863 Buttikon Tel. +41 (0) 55 46 46 111 Fax +41 (0) 55 46 46 222	

Europa (Ost) - Europe (East)

vom Ausland: (0) nach Landeskenziffer weglassen
from abroad: don't dial (0) after country code

<p>Czech Republic - Tschechien</p> <p>Bosch -Rexroth, spol.s.r.o. Hviezdoslavova 5 627 00 Brno Tel.: +420 (0)5 48 126 358 Fax: +420 (0)5 48 126 112</p>	<p>Czech Republic - Tschechien</p> <p>DEL a.s. Strojírenská 38 591 01 Zdar nad Sázavou Tel.: +420 566 64 3144 Fax: +420 566 62 1657</p>	<p>Hungary - Ungarn</p> <p>Bosch Rexroth Kft. Angol utca 34 1149 Budapest Tel.: +36 (1) 422 3200 Fax: +36 (1) 422 3201</p>	<p>Poland – Polen</p> <p>Bosch Rexroth Sp.zo.o. ul. Staszica 1 05-800 Pruszków Tel.: +48 22 738 18 00 – service: +48 22 738 18 46 Fax: +48 22 758 87 35 – service: +48 22 738 18 42</p>
<p>Poland – Polen</p> <p>Bosch Rexroth Sp.zo.o. Biuro Poznan ul. Dabrowskiego 81/85 60-529 Poznan Tel.: +48 061 847 64 62 /-63 Fax: +48 061 847 64 02</p>	<p>Romania - Rumänien</p> <p>East Electric S.R.L. B-dul Basarabie, nr.250, sector 3 73429 Bucuresti Tel./Fax:: +40 (0)21 255 35 07 +40 (0)21 255 77 13 Fax: +40 (0)21 725 61 21 est@mb.roknet.ro</p>	<p>Romania - Rumänien</p> <p>Bosch Rexroth Sp.zo.o. Str. Drobety nr. 4-10, app. 14 70258 Bucuresti, Sector 2 Tel.: +40 (0)1 210 48 25 +40 (0)1 210 29 50 Fax: +40 (0)1 210 29 52</p>	<p>Russia - Russland</p> <p>Bosch Rexroth OOO Wjatskaja ul. 27/15 127015 Moskau Tel.: +7-095-785 74 78 +7-095 785 74 79 Fax: +7 095 785 74 77 laura.kanina@boschrexroth.ru</p>
<p>Russia - Russland</p> <p>ELMIS 10, Internationalnaya 246640 Gomel, Belarus Tel.: +375/ 232 53 42 70 +375/ 232 53 21 69 Fax: +375/ 232 53 37 69 elmis_ltd@yahoo.com</p>	<p>Turkey - Türkei</p> <p>Bosch Rexroth Otomasyon San & Tic. A..S. Fevzi Cakmak Cad No. 3 34630 Sefaköy Istanbul Tel.: +90 212 541 60 70 Fax: +90 212 599 34 07</p>	<p>Slovenia - Slowenien</p> <p>DOMEL Otoki 21 64 228 Zelezniki Tel.: +386 5 5117 152 Fax: +386 5 5117 225 brane.ozebek@domel.si</p>	

Africa, Asia, Australia – incl. Pacific Rim

<p>Australia - Australien</p> <p>AIMS - Australian Industrial Machinery Services Pty. Ltd. 28 Westside Drive Laverton North Vic 3026 Melbourne</p> <p>Tel.: +61 3 93 243 321 Fax: +61 3 93 243 329 Hotline: +61 4 19 369 195 terryobrien@aimservices.com.au</p>	<p>Australia - Australien</p> <p>Bosch Rexroth Pty. Ltd. No. 7, Endeavour Way Braeside Victoria, 31 95 Melbourne</p> <p>Tel.: +61 3 95 80 39 33 Fax: +61 3 95 80 17 33 mel@rexroth.com.au</p>	<p>China</p> <p>Shanghai Bosch Rexroth Hydraulics & Automation Ltd. Waigaoqiao, Free Trade Zone No.122, Fu Te Dong Yi Road Shanghai 200131 - P.R.China</p> <p>Tel.: +86 21 58 66 30 30 Fax: +86 21 58 66 55 23 richard.yang_sh@boschrexroth.com.cn gf.zhu_sh@boschrexroth.com.cn</p>	<p>China</p> <p>Shanghai Bosch Rexroth Hydraulics & Automation Ltd. 4/f, Marine Tower No.1, Pudong Avenue Shanghai 200120 - P.R.China</p> <p>Tel.: +86 21 68 86 15 88 Fax: +86 21 58 40 65 77</p>
<p>China</p> <p>Bosch Rexroth China Ltd. 15/F China World Trade Center 1, Jianguomenwai Avenue Beijing 100004, P.R.China</p> <p>Tel.: +86 10 65 05 03 80 Fax: +86 10 65 05 03 79</p>	<p>China</p> <p>Bosch Rexroth China Ltd. Guangzhou Repres. Office Room 1014-1016, Metro Plaza, Tian He District, 183 Tian He Bei Rd Guangzhou 510075, P.R.China</p> <p>Tel.: +86 20 8755-0030 +86 20 8755-0011 Fax: +86 20 8755-2387</p>	<p>China</p> <p>Bosch Rexroth (China) Ltd. A-5F., 123 Lian Shan Street Sha He Kou District Dalian 116 023, P.R.China</p> <p>Tel.: +86 411 46 78 930 Fax: +86 411 46 78 932</p>	<p>China</p> <p>Melchers GmbH BRC-SE, Tightening & Press-fit 13 Floor Est Ocean Centre No.588 Yanan Rd. East 65 Yanan Rd. West Shanghai 200001</p> <p>Tel.: +86 21 6352 8848 Fax: +86 21 6351 3138</p>
<p>Hongkong</p> <p>Bosch Rexroth (China) Ltd. 6th Floor, Yeung Yiu Chung No.6 Ind Bldg. 19 Cheung Shun Street Cheung Sha Wan, Kowloon, Hongkong</p> <p>Tel.: +852 22 62 51 00 Fax: +852 27 41 33 44 alexis.siu@boschrexroth.com.hk</p>	<p>India - Indien</p> <p>Bosch Rexroth (India) Ltd. Electric Drives & Controls Plot. A-58, TTC Industrial Area Thane Turbhe Midc Road Mahape Village Navi Mumbai - 400 701</p> <p>Tel.: +91 22 7 61 46 22 Fax: +91 22 7 68 15 31</p>	<p>India - Indien</p> <p>Bosch Rexroth (India) Ltd. Electric Drives & Controls Plot. 96, Phase III Peenya Industrial Area Bangalore – 560058</p> <p>Tel.: +91 80 41 17 02 -11...-18 Fax: +91 80 83 94 345 +91 80 83 97 374 mohanvelu.t@boschrexroth.co.in</p>	<p>India - Indien</p> <p>Bosch Rexroth (India) Ltd. 1st Floor, S-10 Green Park ext. Market New Delhi – 110016</p> <p>Tel.: +91 1 16 56 68 88 Fax: +91 1 16 56 68 87</p>
<p>Indonesia - Indonesien</p> <p>PT. Bosch Rexroth Building # 202, Cilandak Commercial Estate Jl. Cilandak KKO, Jakarta 12560</p> <p>Tel.: +62 21 7891169 (5 lines) Fax: +62 21 7891170 - 71</p>	<p>Japan</p> <p>Bosch Rexroth Automation Corp. Service Center Japan Yutakagaoka 1810, Meito-ku, NAGOYA 465-0035, Japan</p> <p>Tel.: +81 52 777 88 41 +81 52 777 88 53 +81 52 777 88 79 Fax: +81 52 777 89 01</p>	<p>Japan</p> <p>Bosch Rexroth Automation Corp. Electric Drives & Controls 1F, I.R. Building Nakamachidai 4-26-44, Tsuzuki-ku YOKOHAMA 224-0041, Japan</p> <p>Tel.: +81 45 942 72 10 Fax: +81 45 942 03 41</p>	<p>Korea</p> <p>Bosch Rexroth-Korea Ltd. Electric Drives and Controls Bongwoo Bldg. 7FL, 31-7, 1Ga Jangchoong-dong, Jung-gu Seoul, 100-391</p> <p>Tel.: +82 234 061 813 Fax: +82 222 641 295</p>
<p>Korea</p> <p>Bosch Rexroth-Korea Ltd. 1515-14 Dadae-Dong, Saha-Ku Electric Drives & Controls Pusan Metropolitan City, 604-050</p> <p>Tel.: +82 51 26 00 741 Fax: +82 51 26 00 747 gyhan@rexrothkorea.co.kr</p>	<p>Malaysia</p> <p>Bosch Rexroth Sdn.Bhd. 11, Jalan U8/82, Seksyen U8 40150 Shah Alam Selangor, Malaysia</p> <p>Tel.: +60 3 78 44 80 00 Fax: +60 3 78 45 48 00 hockhwa@hotmail.com rexroth1@tm.net.my</p>	<p>Singapore - Singapur</p> <p>Bosch Rexroth Pte Ltd 15D Tuas Road Singapore 638520</p> <p>Tel.: +65 68 61 87 33 Fax: +65 68 61 18 25 sanjay.nemade@boschrexroth.com.sg</p>	<p>South Africa - Südafrika</p> <p>TECTRA Automation (Pty) Ltd. 71 Watt Street, Meadowdale Edenvale 1609</p> <p>Tel.: +27 11 971 94 00 Fax: +27 11 971 94 40 Hotline: +27 82 903 29 23 georgv@tectra.co.za</p>
<p>Taiwan</p> <p>Bosch Rexroth Co., Ltd. Taichung Branch 1F., No. 29, Fu-Ann 5th Street, Xi-Tun Area, Taichung City Taiwan, R.O.C.</p> <p>Tel.: +886 - 4 -23580400 Fax: +886 - 4 -23580402 charlie.chen@boschrexroth.com.tw jim.lin@boschrexroth.com.tw david.lai@boschrexroth.com.tw</p>	<p>Thailand</p> <p>NC Advance Technology Co. Ltd. 59/76 Moo 9 Ramintra road 34 Tharang, Bangkhen, Bangkok 10230</p> <p>Tel.: +66 2 943 70 62 +66 2 943 71 21 Fax: +66 2 509 23 62 sonkawin@hotmail.com</p>		

Nordamerika – North America

USA Headquarters - Hauptniederlassung Bosch Rexroth Corporation Electric Drives & Controls 5150 Prairie Stone Parkway Hoffman Estates, IL 60192-3707 Tel.: +1 847 6 45 36 00 Fax: +1 847 6 45 62 01 servicebrc@boschrexroth-us.com repairbrc@boschrexroth-us.com	USA Central Region - Mitte Bosch Rexroth Corporation Electric Drives & Controls Central Region Technical Center 1701 Harmon Road Auburn Hills, MI 48326 Tel.: +1 248 3 93 33 30 Fax: +1 248 3 93 29 06	USA Southeast Region - Südwest Bosch Rexroth Corporation Electric Drives & Controls Southeastern Technical Center 3625 Swiftwater Park Drive Suwanee, Georgia 30124 Tel.: +1 770 9 32 32 00 Fax: +1 770 9 32 19 03	USA SERVICE-HOTLINE - 7 days x 24hrs - +1-800-REX-ROTH +1-800-739-7684
USA East Region – Ost Bosch Rexroth Corporation Electric Drives & Controls Charlotte Regional Sales Office 14001 South Lakes Drive Charlotte, North Carolina 28273 Tel.: +1 704 5 83 97 62 +1 704 5 83 14 86	USA Northeast Region – Nordost Bosch Rexroth Corporation Electric Drives & Controls Northeastern Technical Center 99 Rainbow Road East Granby, Connecticut 06026 Tel.: +1 860 8 44 83 77 Fax: +1 860 8 44 85 95	USA West Region – West Bosch Rexroth Corporation 7901 Stoneridge Drive, Suite 220 Pleasant Hill, California 94588 Tel.: +1 925 227 10 84 Fax: +1 925 227 10 81	
Canada East - Kanada Ost Bosch Rexroth Canada Corporation Burlington Division 3426 Mainway Drive Burlington, Ontario Canada L7M 1A8 Tel.: +1 905 335 55 11 Fax: +1 905 335-41 84 michael.moro@boschrexroth.ca	Canada West - Kanada West Bosch Rexroth Canada Corporation 5345 Goring St. Burnaby, British Columbia Canada V7J 1R1 Tel.: +1 604 205-5777 Fax: +1 604 205-6944 david.gunby@boschrexroth.ca	Mexico Bosch Rexroth Mexico S.A. de C.V. Calle Neptuno 72 Unidad Ind. Vallejo 07700 Mexico, D.F. Tel.: +52 5 754 17 11 +52 5 754 36 84 +52 5 754 12 60 Fax: +52 5 754 50 73 +52 5 752 59 43 mariofelipe.hernandez@boschrexroth.com.mx	Mexico Bosch Rexroth S.A. de C.V. Calle Argentina No 3913 Fracc. las Torres 64930 Monterrey, N.L. Tel.: +52 8 333 88 34...36 +52 8 349 80 91...93 Fax: +52 8 346 78 71 mario.quiroga@boschrexroth.com.mx

Südamerika – South America

Argentina - Argentinien Bosch Rexroth S.A.I.C. "The Drive & Control Company" Acassuso 48 41/47 1605 Munro Provincia de Buenos Aires Tel.: +54 11 4756 01 40 Fax: +54 11 4756 01 36 victor.jabif@boschrexroth.com.ar	Argentina - Argentinien NAKASE Servicio Tecnico CNC Calle 49, No. 5764/66 B1653AOX Villa Balester Provincia de Buenos Aires Tel.: +54 11 4768 36 43 Fax: +54 11 4768 24 13 nakase@usa.net nakase@nakase.com gerencia@nakase.com (Service)	Brazil - Brasilien Bosch Rexroth Ltda. Av. Tégula, 888 Ponte Alta, Atibaia SP CEP 12942-440 Tel.: +55 11 4414 56 92 +55 11 4414 56 84 Fax sales: +55 11 4414 57 07 Fax serv.: +55 11 4414 56 86 alexandre.wittwer@rexroth.com.br	Brazil - Brasilien Bosch Rexroth Ltda. R. Dr.Humberto Pinheiro Vieira, 100 Distrito Industrial [Caixa Postal 1273] 89220-390 Joinville - SC Tel./Fax: +55 47 473 58 33 Mobil: +55 47 9974 6645 prochnow@zaz.com.br
Columbia - Kolumbien Refflutec de Colombia Ltda. Calle 37 No. 22-31 Santafé de Bogotá, D.C. Colombia Tel.: +57 1 368 82 67 +57 1 368 02 59 Fax: +57 1 268 97 37 reflutec@neutel.com.co reflutec@007mundo.com			

Bosch Rexroth AG
Electric Drives and Controls
Bgm.-Dr.-Nebel-Str. 2
97816 Lohr a. Main, Germany
info@boschrexroth.de
www.boschrexroth.de



273697