

DDC 1.2

Digital Intelligent Servo Drive with Protection

Category IP 65

Project Planning Manual

DOK-DIAX02-DDC01*****-PRJ1-EN-P



Title DDC 1.2 Digital Intelligent Servo Drive with Protection Category IP 65 / (basic unit)

Type of documentation Project Planning Manual

Document Type DOK-DIAX02-DDC01*****-PRJ1-EN-E1,44

Internal file reference

- Mappe 13
- DDC01-PJ.pdf
- 209-0069-4381-01

Reference This electronic document is based on the hardcopy document with document desig.: DOK-DIAX02-DDC01*****-PRJ1-EN-P

Purpose of the documentation It supplies information on:

- the electrical construction
- mounting the drive controller (basic unit)
- installing the electrical leads to the drive controller

Editing sequence

Doc. designations of previous documents	Status	Comment
209-0069-4381-00-EN	03/95	1st edition
DOK-DIAX02-DDC01*****-PRJ1-EN-P	08/96	new edition
DOK-DIAX02-DDC01*****-PRJ1-EN-E1,44	01/97	1st edition of the E-Doc

Copyright © INDRAMAT GmbH, 1994
 Copying this document, and giving it to others and the use or communication of the contents thereof without express authority, are forbidden. Offenders are liable to the payment of damages. All rights are reserved in the event of the grant of a patent or the registration of a utility model or design (DIN 34-1).
 The electronic documentation (E-doc) may be copied as often as needed if such are to be used by the consumer for the purpose intended.

Published by INDRAMAT GmbH • Bgm.-Dr.-Nebel-Straße 2 • 97816 Lohr, Germany
 Telefon 0049-93 52 / 40-0 • Tx 689421 • Fax 0049-93 52 / 40-48 85
 Dept. ENA (DE, FS)

Validity We reserve the right to revise the contents of the documentation and to make changes in product availability.

Table of Contents

Seite

1. Introducing the System	5
1.1. DDC 1.2 Servo Drive	6
1.2. Functional Performance Features	7
1.3. Command Interface Card	8
1.4. Software Module	9
1.5. Auxiliary Plug-In Cards	9
1.6. Configuration Rating Plate	10
2. Technical Data / Ambient Conditions	11
2.1. Data Sheet	11
2.2. Operating Conditions	12
3. Electrical Connections -Installation Guidelines	13
3.1. Terminal diagram	14
3.2. Power Connections	15
3.3. Grounding Conditions	16
3.4. Power Connection cross sections and Fuses	17
3.5. Transformers	19
3.6. DST Three-Phase Autotransformers for Mounting in Control Enclosures	20
3.7. DLT Three-Phase Isolating Transformers for Mounting in Control Enclosures	21
3.8. Three-Phase Autotransformers in IP 55 Housing	22
3.9. Motor Power Connection	23
3.10. Motor Feedback Connection	27
3.11. Interface to NC Control Unit	28
3.12. Control Circuit of the DDC Mains Contactor	29
3.13. Control Circuit in the DDC with Dynamic Braking	30
3.14. Control circuit of the DDC Mains Contactor Without Dynamic Braking	32
3.15. Control Circuit of the DDC Mains Contactor with E-Stop Relays ..	34
3.16. Control Inputs	36

3.17. Signal and Diagnostics Outputs	37
3.18. Signal Voltages	38
3.19. Reading Drive Parameters	39
3.20. Regenerated Power	39
3.21. Fault Current Protective Device	40
3.22. High-Voltage Testing	40
4. Mounting the DDC 1.2	41
4.1. DDC 1.2-N - dimensional data	41
4.2. Front View of DDC 1.2-N	42
4.3. Power Connections	43
4.4. Minimum Clearances	44
5. Ordering Information	46
5.1. Type Codes for the DDC 1.2	46
5.2. Accessories for Connections	47
5.3. Item List	50
6. Index	51

1. Introducing the System

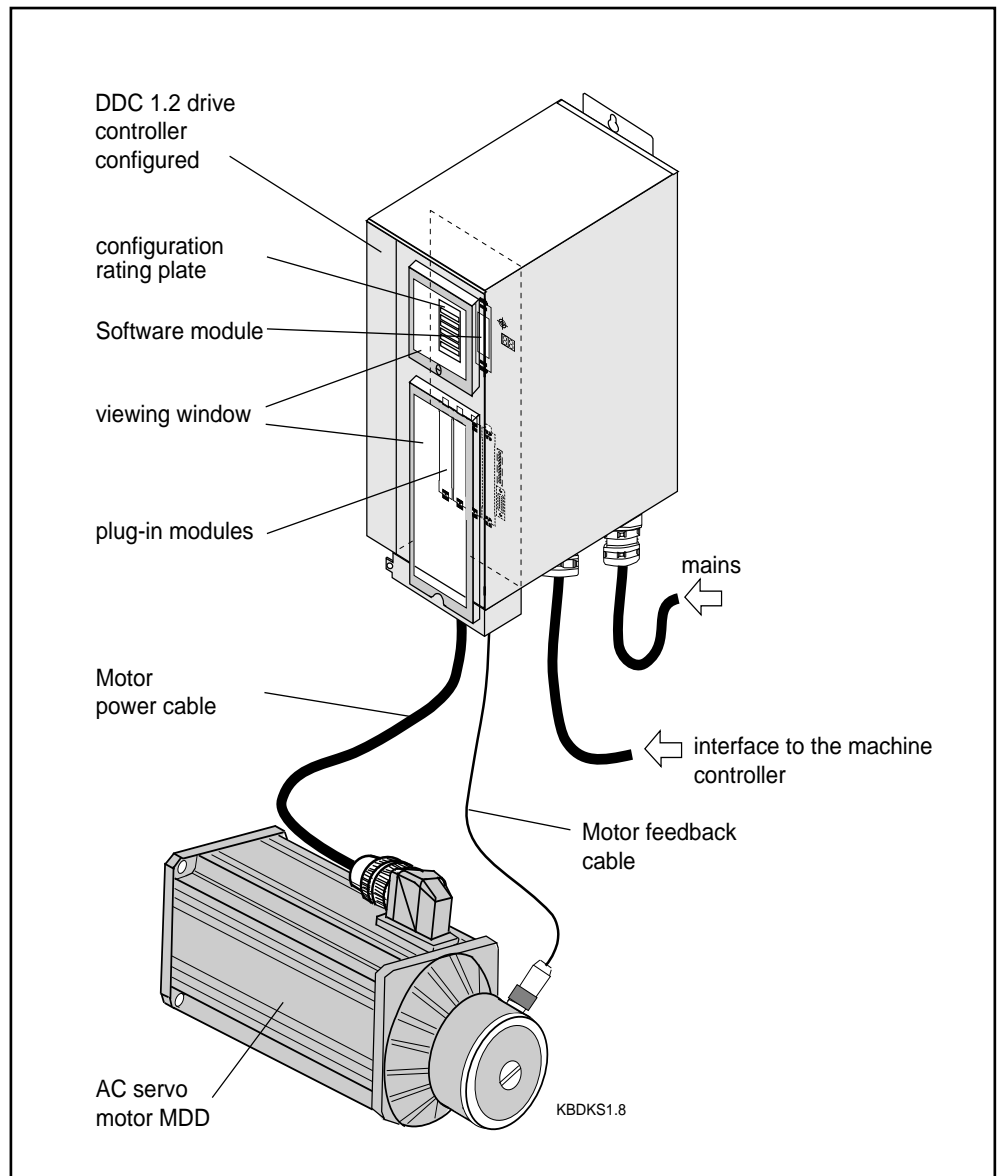

Fig. 1.1: Digital AC drive with DDC drive controller

Digital AC Drive

Digital AC drives are microprocessor controlled, brushless, three-phase drives which are highly dynamic and have precision servo-control features.

All

- drive control,
- monitoring,
- parametrization and
- diagnostics operations

are performed digitally with a signal processor.

The drive features needed for precise servo-applications are available to the drive because of the high-resolution rotor position measurements across the entire speed range.

1.1. DDC 1.2 Servo Drive

IP65 is the protection category of a DDC 1.2. It can be installed directly at the feeder even under less favorable environmental and manufacturing conditions. This avoids long cables susceptible to faults.

Basic unit A DC bus converter is built into the basic unit as well as the bleeder resistor for the energy generated during braking, a mains contactor for disconnecting the power and a power section for the control voltages. Plug-in cards are inserted into slots U1 through U5, depending on the application requirements.

A configured DDC is supplied by INDRAMAT as a completely assembled unit.

Drive controller configuration Such a servo drive is made up of the following components:

- the basic unit
- the command interface card (see section 1.3)
- the software module (see section 1.4)
- optional auxiliary plug-in modules (see section 1.5)
- the configuration rating plate (see section 1.6)

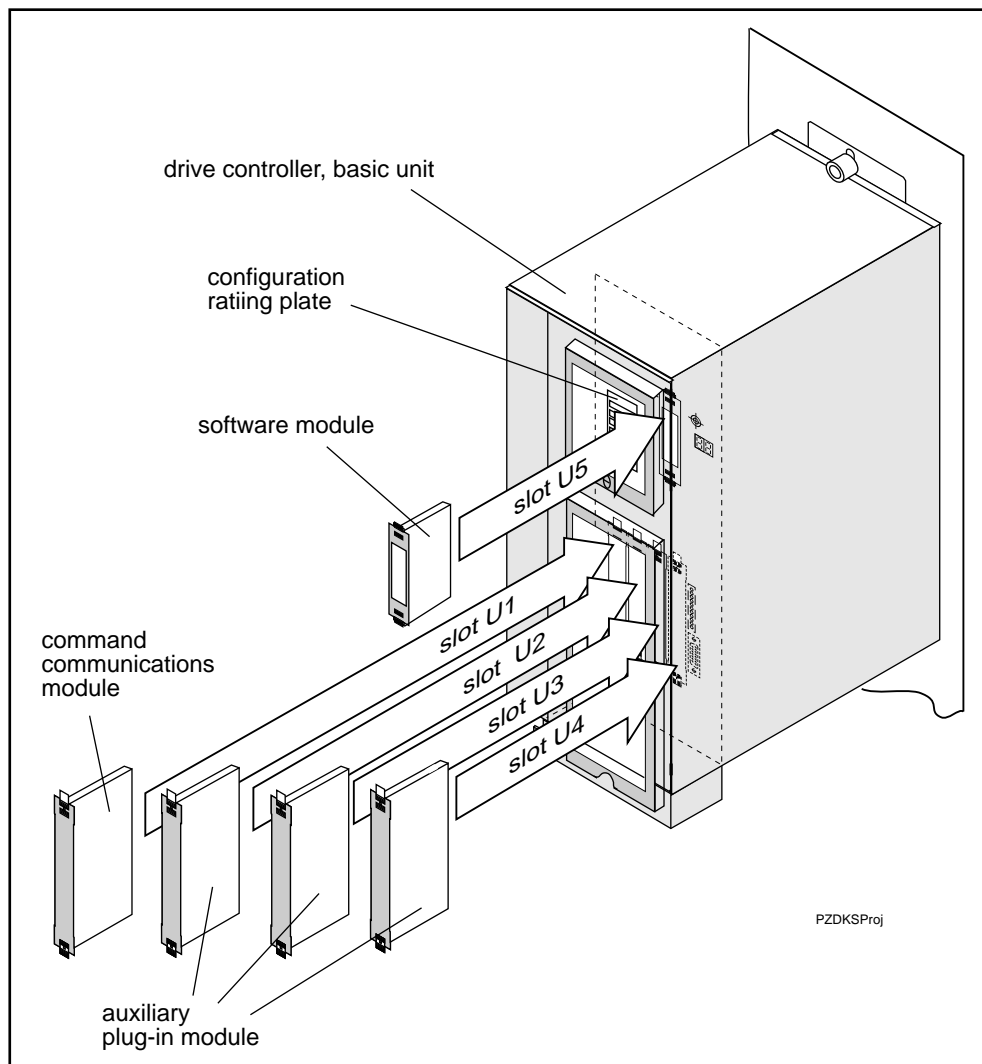

Fig. 1.2: DDC 1 drive controller configuration

1.2. Functional Performance Features

Protection Category IP 65:

- space-saving installation, without a control cabinet, directly at the feeder
- elimination of long connections between motor and drive which are susceptible to interference

Power shutoff via integrated protection system in DDC:

- power supply isolated by a contactor built into the unit
- direct connection to 220V three-phase power source
- a longer lifespan due to currentless switching

Integral DC bus dynamic braking:

- If trouble is encountered in the electronic circuitry of the drive, the drive can be decelerated and stopped with an integral dynamic brake system.

Inrush current limit:

- The inrush current does not need to be considered when selecting fuses or circuit breakers for the input power.

Flexibility for specific applications:

- The functions implemented on the drive can be matched to the given application by installing various plug-in modules in the servo drive.

Motor holding brake:

- Control and monitoring of the holding brake of the motor is integrated inside the servo drive unit.

Programmable error reactions:

- In the event of power, drive, or system faults, the drive performs the programmed error reaction.

Easy to service:

- Signal cables are connected via screw terminals.
- Extensive diagnostics via alphanumeric display.

1.3. Command Interface Card

Depending upon type, the command interface module is either the interface to the NC control unit or a positioning control unit with interfaces to the hand terminal or the NC control unit of the machine.

The following command interface cards are available:

- SERCOS interface, type: DSS 1.1, DSS 1.3
- ANALOG interface with incremental encoder emulator, type: DAE 1.1
- ANALOG interface with absolute encoder emulator, type: DAA 1.1
- Positioning module, type: DLC 1.1

SERCOS interface Type: DSS 1.1, DSS 1.3

The "SERCOS interface DSS" card allows the digital drives to be operated with SERCOS interface-compatible controllers via optical fiber cables. The interface also has inputs for evaluating reference switches, position limit switches and sensors.

*ANALOG interface
with incremental
encoder emulator* Type: DAE 1.1

The "ANALOG interface with incremental encoder emulator" card permits the intelligent digital AC servo drive to be operated with conventional controllers via an analog interface. It also contains control inputs and signal outputs for communication with attached controllers, and it outputs incremental encoder signals to be used as an actual position value.

*ANALOG interface
with absolute encoder
emulator* Type: DAA 1.1

The "ANALOG interface with absolute encoder emulator" card permits the intelligent digital AC servo drive to be operated with conventional controllers via an analog interface. It also contains control inputs and signal outputs for communications with an attached controller and it outputs actual absolute position values in accordance with SSI standards (**S**ynchronous **S**erial **I**nterface).

*Single-axis positioning
module* Type: DLC 1.1

The "single-axis positioning module" card upgrades the servo drive to perform stand-alone, single-axis position control. This card can be programmed with up to 3,000 program blocks. Each program block defines a sequence of movements, a specific condition of the inputs to be monitored, or the outputs to be set.

1.4 Software Module

Type: DSM 2.1

Parameters stored in the software module are used to tune the drive to the motor and the mechanics.

Advantage when replacing unit

The software module contains both the operating software and the parameters. This module ensures that when hardware is replaced, the previously entered parameters are not lost and can be carried over to the new hardware by simply plugging in the old software module.

Duplication

Software modules can be duplicated for use in other, identical machines or for storage purposes.

Standard software module

The drive parameter values set by Indramat are stored in the feedback of the MDD motors. These can be activated upon request at the time of commissioning.

The user-specific parameters are set at the machine to the machine-dependent values.



Documentation and administration of all user parameter values is the sole responsibility of the user.

1.5 Auxiliary Plug-In Cards

The heading "auxiliary plug-in cards" includes the following:

Input/output interface

Type: DEA 4.1, DEA 5.1, DEA 6.1

These plug-in cards each have 15 inputs and 16 outputs. The drive uses these to exchange binary signals with a programmable controller.

The three types differ with regard to the internal address set on the card.

Incremental position interface

Type: DEF 1.1, DEF 2.1

The auxiliary plug-in cards "incremental position interface" are used to receive squarewave signals so that data from an external measuring system located directly on the moving machine element can be input to the servo drive. The cards differ according to which internal address is set on the card.

High-resolution positioning interface

Type: DLF 1.1

The auxiliary plug-in card "high-resolution position interface" is used to transfer sine wave signals so that data from an external measuring system directly mounted to the moving machine elements can be input to the servo drive.



The technical data and terminal diagrams for the plug-in cards can be found in document "Plug-in modules for digital intelligent servo drives". doc. no.: 209-00069-4356.

1.6 Configuration Rating Plate

The configuration rating plate contains the type codes for:

- the configured servo drive
- the basic unit
- the software module in slot U5
- the plug-in cards in slots U1 through U4

These type codes can be used to determine which components must be located in which slots.

In the event of malfunctions, the information on the configuration rating plate can be used to obtain a corresponding unit or to configure a basic unit. A replacement unit results when a basic unit is configured with the cards identified on the configuration rating plate.



The configuration rating plate indicates which cards are installed on the servo drive. Before commissioning the servo drive, check to be certain that the actual configuration matches that on the configuration rating plate.

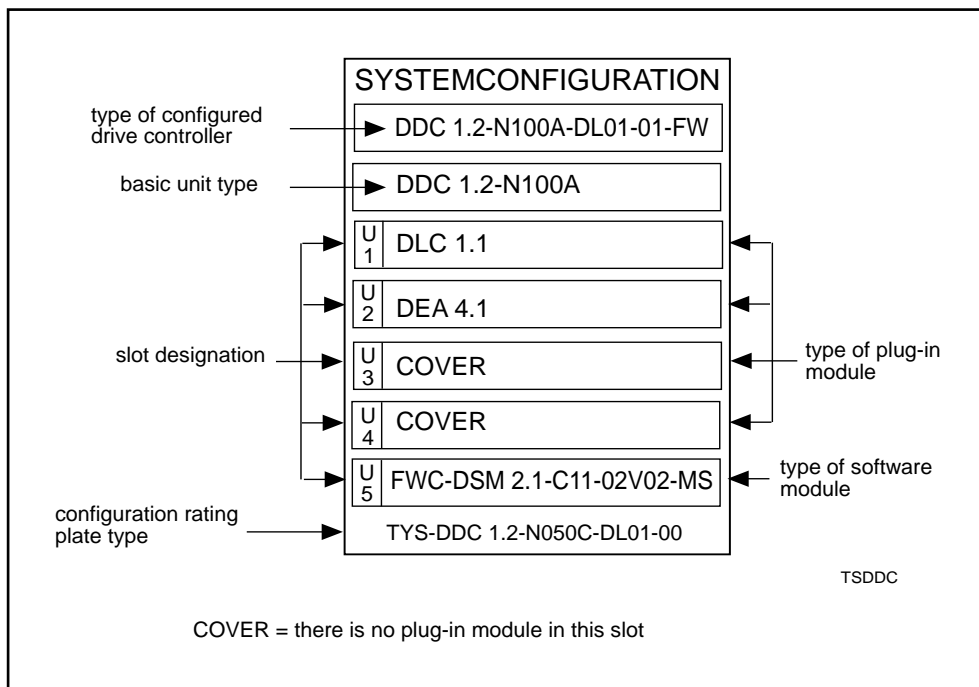

Fig. 1.3: An example of a configuration rating plate

2. Technical Data / Ambient Conditions

2.1. Data Sheet

Designation		DDC 1.2-N050C	DDC 1.2-N100A	DDC 1.2-N200A
Power section				
Input voltage	U(N) (V)	3x 220 V (+15%/-10%) or 3x 230 V (+10%/-15%)		
Frequency	f(N) (Hz)	50 ... 60 Hz		
Peak current	I(peak) (A)	50	100	200
Short-term current for 50 % at 100 s duty cycle time	I(S6-100s) (A)	50	70	90
Continuous current (average)	I(cont) (A)	25	35	45
Pulse frequency (PWM-frequency)	f(T) (kHz)	8	4	
Required connected load	S(An) (kVA)	Depends on motor/servo drive combination - see selection lists		
Power requirement with maximum drive load	S(An) (kVA)	6	18	22.5
Short term mechanical operating load for 50 % at 100 s duty cycle time, approx.	P(S6-100s) (kW)	8	12	15
Continuous mechanical load, average	P(mech) (kW)	4	6	7.5
Usable mechanical peak load, approx.	P(mSp) (kW)	8.5	17	33
Power loss at maximum device load without bleeder power loss	P(V) (W)	500		
Continuous bleeder power	P(BD) (kW)	0,25	0.25	0.25
Peak bleeder power	P(BM) (kW)	10	20	40
Maximum regenerated power	W(max) (kWs)	5	10	20
Weight of basic unit	m (kg)	21	22	22
Environmental conditions				
Permissible ambient temperature for rated specifications	T(amb) °C	+ 5 ... + 45 °C		
Maximum ambient temperature for derated specifications	T(m.amb) °C	+ 55 °C		
Storage and shipping temp.	T(L) °C	- 30 ... + 85 °C		
Maximum installation elevation without derating		1000 meters above sea level		
Permissible relative humidity		max. 95 %		
Permissible absolute humidity		25 g water / m ³ air		
Degree of contamination		- non-conductive dirt contamination - no condensate		
Protection category		IP 65 as per EN 60 529 (IEC 529)		

Fig. 2.1: Technical data - DDC 1.2

2.2. Operating Conditions

Increased ambient temperatures

The torque and power ratings listed in the selection documentation apply to an ambient temperature range of +5° to +45° C. Maximum permissible ambient temperature can equal up to +55° C. Otherwise, there is a drop in power as depicted in the following figure.

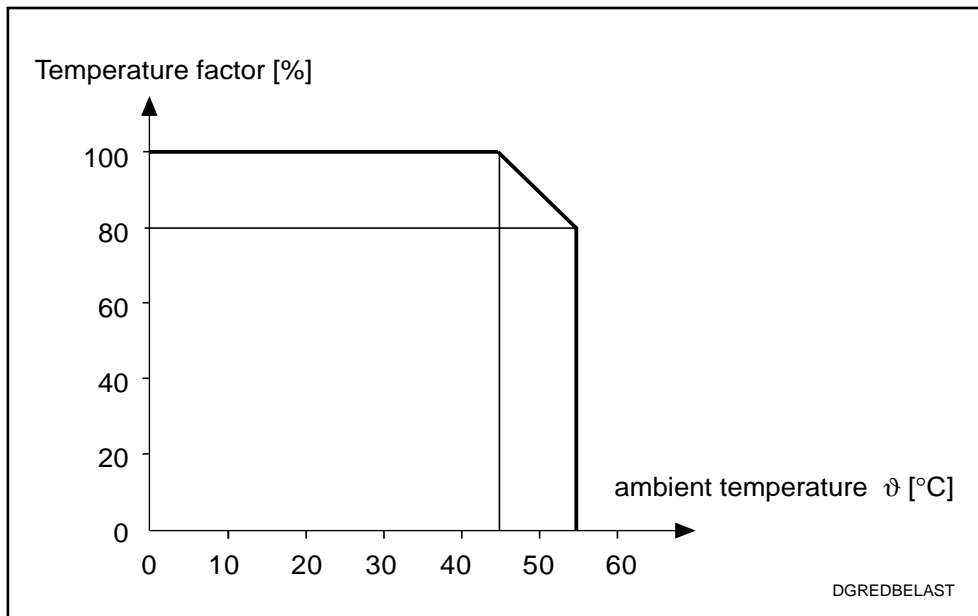

Fig. 2.2: Reductoin in power data with increased ambient temperature

Installation above 1000 meters

If the unit is installed at elevations higher than 1000 meters above sea level, then torque and power ratings will drop. The following figure depicts this drop.

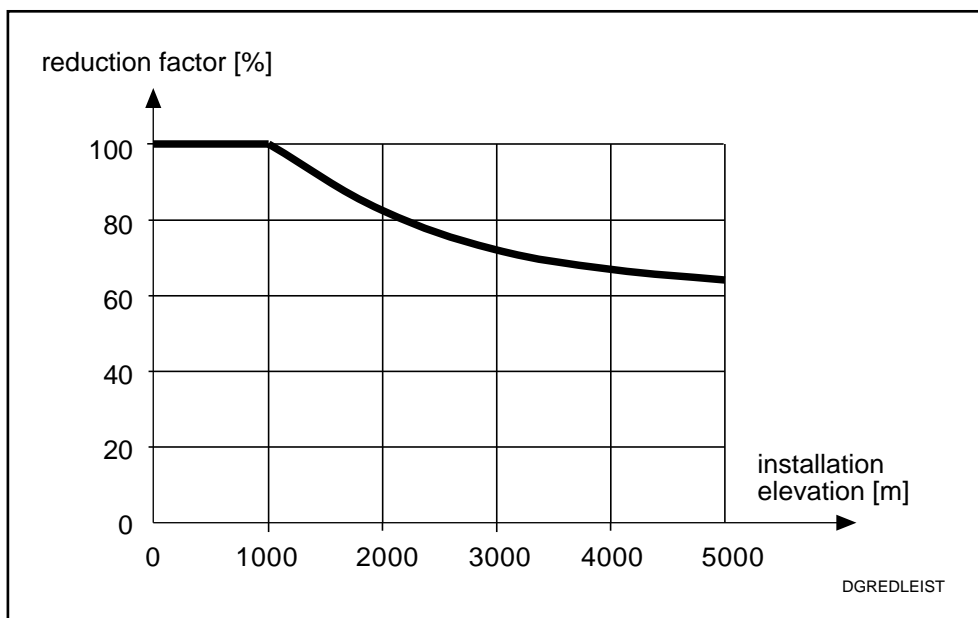

Fig. 2.3: Reduction in power data at elevations greater than 1000 meters.

3. Electrical Connections - Installation Guidelines



The DDC 1.2 terminal diagram found in this document is a recommendation of the manufacturer of the unit. The circuit diagrams of the machine builder must be used for installation.

3.1. Terminal diagram

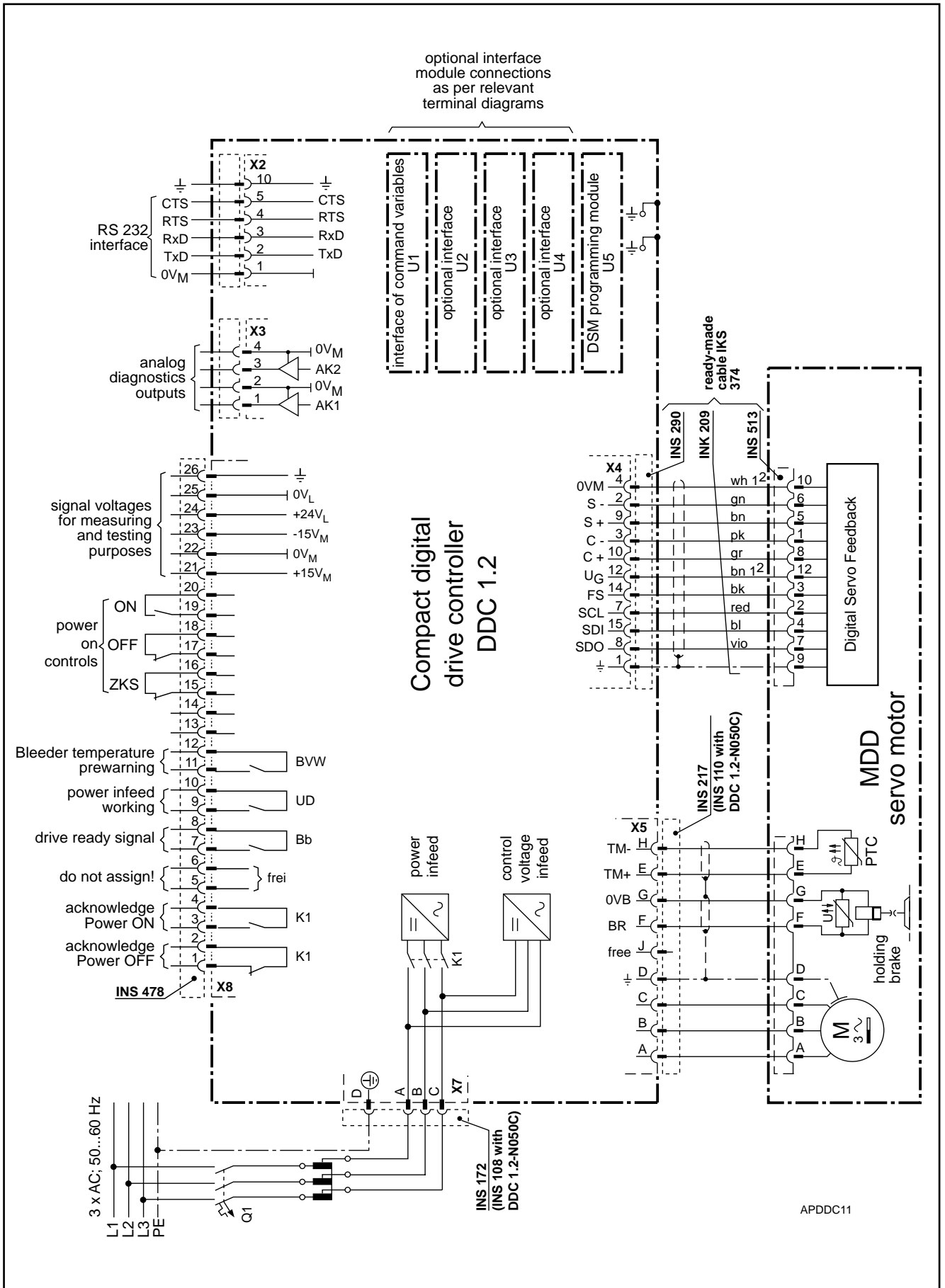

Fig. 3.1: Terminal diagram of DDC 1.2 servo drive

3.2. Power Connections

Connection voltage The DDC 1.2 drives can be connected to three-phase mains rated at AC 220V (+ 15 % -10%) or AC 230V (+10 / -15%).

Frequency 50 ... 60 Hz



To operate the DDC 1.2 in residential and light industrial areas, it may be necessary to install an rf suppression filter in the mains supply line so that the limits for the emission of interference (radio interference suppression) are not exceeded.

Connected load The connected load must be calculated when determining supply line diameters, fuses and matching transformers.

$$S_{AN} = \frac{M_{eff} \cdot n_{AV}}{9550} \cdot F + 0,125kVA$$

S_{AN} = connected load in kVA
 M_{eff} = effective motor torque in Nm
 n_{AV} = average motor speed in min-1
 F = factor for motor and drive efficiency and current form
 F = 1.75 with a three-phase connection
 F = 2.1 with a single-phase connection
 0.125 = power consumption of the control unit voltage source in kVA



The average motor speed for feed functions in transfer facilities is generally no greater than 25% of the rapid traverse speed.

In some cases, it may be necessary to precisely calculate average motor speed.

3.3. Grounding Conditions

Grounded threephase systems

With the help of an autotransformer, voltages can be adapted to three-phase mains which is in reference to the ground (TN or TT mains). The DDC 1 can be directly connected to 3 x AC 220 V mains.

Ungrounded threephase systems

There is an increased danger in ungrounded mains (IT mains) that overvoltages will occur between the phases and the housing. The DDC 1 should only be operated with such systems, if:

- it is connected across an isolation transformer or
- if the installation is protected with an overvoltage conductor.



Connecting the DDC 1.2 across an isolation transformer offers the best possible protection against overvoltage and the greatest operating safety!

Permissible overvoltage levels

The voltage between phase connections (A, B and C) and the DDC 1.2 housing can equal 230 V (effective).

Non-periodic overvoltages as per VDE 0160 between phases and housing are acceptable for the DDC 1.2 to the extent as shown below:

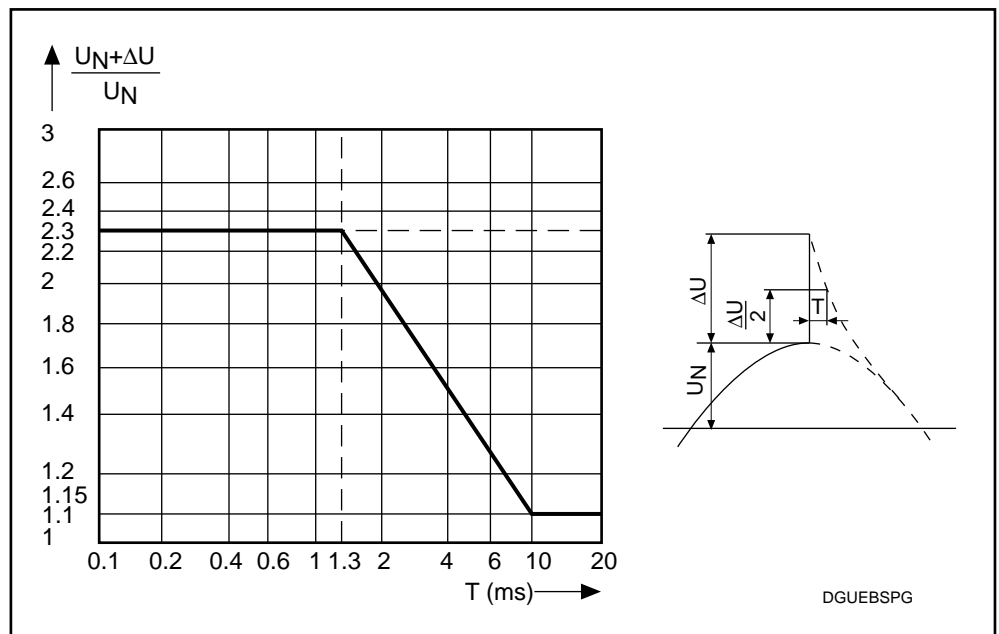

Fig. 3.3: Permissible non-periodic voltages as per VDE 0160

The DDC 1.2 can be connected to 3 x AC 230 V mains. The maximum permissible non-periodic overvoltage thus equals:

$$230V \cdot \sqrt{2} \cdot 2.3 = 745V$$

3.4. Power Connection cross sections and Fuses

The power connections of the DDC 1.2 can be protected with either power circuit breakers or slow-blo gL-type fuses.

Fusing for three-phase connections

The recommended fuse on the input side of the matching transformer with 3 x AC 400 V mains.

A power circuit breaker or slow-blow fuse is generally used on the input side of a matching transformer. The use of power circuits has the advantage that it is not possible to operate with two phases when one fuse is blown out.

The recommended fuses and line cross sections apply if INDRAMAT transformers are used. Make sure that the secondary lines are protected against short circuiting, in particular, if an isolation transformer with low-power is used.

Transf. power in kVA	Current in A		Rec. power circ. breaker ¹⁾ (motor circ. break.) type Siemens	Tuning range in A	Tuning value in A	Rec. slow-blow fuse gL class
	primary	second.				
2.0	2.9	5	3VU1300-.MK00	4 ... 6	4	6A slow-blow
2.5	3.6	6.3	3VU1300-.ML00	6 ... 10	6	10A slow-blow
3.5	5.1	8.8	3VU1300-.MM00	10 ... 16	10	16A slow-blow
4.0	5.8	10	3VU1300-.MM00	10 ... 16	10	16A slow-blow
5.0	7.2	12.6	3VU1300-.MN00	14 ... 20	14	20A slow-blow
7.5	10.8	18.8	3VU1300-.MP00	18 ... 25	18	20A slow-blow
10	14.5	25.1	3VU1300-.MP00	18 ... 25	18	20A slow-blow
12.5	18.1	31.4	3VU1600-.MP00	22 ... 32	27	25A slow-blow
15	21.7	37.7	3VU1600-.MQ00	28 ... 40	32	25A slow-blow
18	26.0	45.2	3VU1600-.MQ00	28 ... 40	39	35A slow-blow
20	28.9	50.3	3VU1600-.MQ00	28 ... 40	40	35A slow-blow
25	36.1	62.8	3VU1600-.MR00	36 ... 50	50	50A slow-blow

Direct connection to 3 x AC 220 V mains

Fuses on the secondary side of the matching transformer or if connected to 3x AC 220V mains.

If fuses are to be placed on the secondary side of the matching transformer or if the DDC is connected to 3 x 220 V mains, then select the fusing as per the current in the connecting cable, but not less than 16A (16 A slow-blow fuse or power circuit breaker 3VU1300-.MM00).

1) Note the maximum size of the power circuit breaker as indicated by the manufacturer !

Cross section of the DDC 1 connecting cable Calculate the current in the connecting cable to determine cable cross section.

threephase connection	
$I_L = \frac{S_{AN}}{\sqrt{3} \cdot 230V}$	
I_L	= current in connecting lead indicated in A
S_{AN}	= connected load indicated in VA

The applicable guidelines must be followed when determining cable cross sections.

If fuses are placed on the input side only when transformers are used, then protect the secondary line against short-circuiting.

Recommended cable for the DDC 1 connecting cable Ready-made INDRAMAT cables are available as connecting cables for the DDC 1.2 The recommended cable types and cross sections apply where INDRAMAT transformers and fuses are used.

The cable recommended in the following table has a current capacity as per EN 60 204 (VDE 0113) – E mode of installation.

Recommended cable for three-phase connections

Drive controllers	Transf.- (conn.) load in kVA	Connector on drive	Recommended secondary cable with INDRAMAT autotransformers		Recommended secondary cable with INDRAMAT isolating transformers	
			individual parts	ready- made	individual parts	ready- made
DDC 1.2-N050C	2 and 2.5	INS 108/02	INK 250 (1.5mm ²)	IKL 234	INK 202 (2.5mm ²)	IKL 241
	3.5 and 4	INS 108/02	INK 250 (1.5mm ²)	IKL 234	INK 204 (6mm ²)	request
	5	INS 108/02	INK 250 (1.5mm ²)	IKL 234	INK 202 (2.5mm ²)	IKL 241
	7.5	INS 108/03	INK 202 (2.5mm ²)	IKL 241	INK 202 (2.5mm ²)	IKL 241
DDC 1.2-N...A	2 and 2.5	INS 172/25	INK 202 (2.5mm ²)	IKL 232	INK 202 (2.5mm ²)	IKL 232
	3.5 and 4	INS 172/25	INK 202 (2.5mm ²)	IKL 232	INK 204 (6mm ²)	IKL 243
	5 and 7.5	INS 172/25	INK 202 (2.5mm ²)	IKL 232	INK 202 (2.5mm ²)	IKL 232
	10	INS 172/25	INK 203 (4mm ²)	IKL 242	INK 203(4mm ²)	IKL 242
	12.5	INS 172/06	INK 204 (6mm ²)	IKL 243	INK 204 (6mm ²)	IKL 243
	15.18 and 20	INS 172/10	INK 205 (10mm ²)	IKL 244	INK 205 (10mm ²)	IKL 244
25	INS 172/16	INK 206 (16mm ²)	IKL 245	INK 206 (16mm ²)	IKL 245	

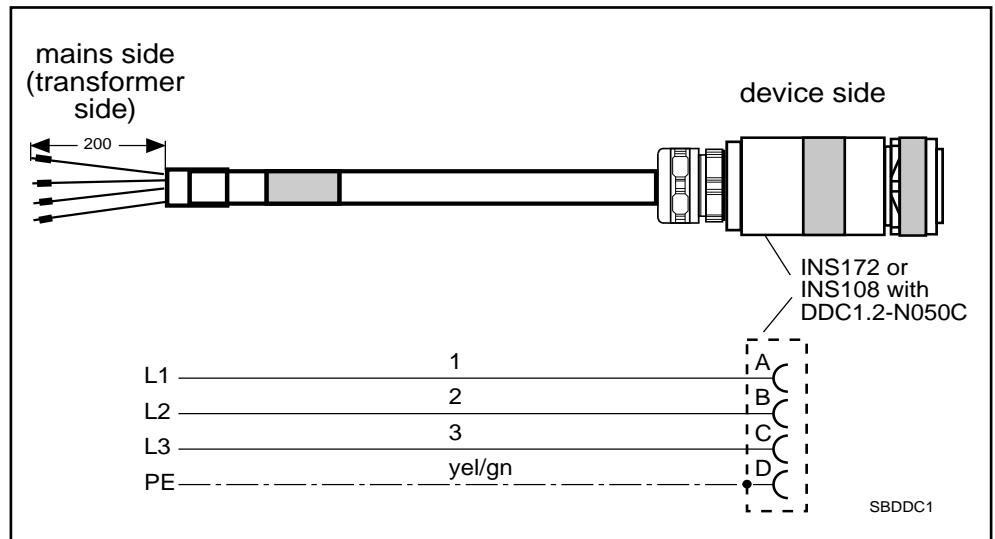

Fig. 3.4: Power supply cable for a DDC 1.2

3.5. Transformers

Transformers for installation in control cabinets (IP 00) and transformers in housing with protection category IP 55 are available for adapting the mains voltage to the DDC 1 connecting voltage.

Autotransformers for installation in a control enclosure

Autotransformers are preferred for adapting voltages (see section 3.3). Their protection category is IP 00, and their ambient temperature 40°C. See section 3.6 for available options.

Isolating transformers for installation in a control enclosure

For special mains conditions, isolating transformers are recommended (see section 3.3). Protection category is IP 00; ambient temperature 40°C. See section 3.7 for available options.

Autotransformers in IP 55 housing

Autotransformers are preferably used for adapting voltages (see section 3.3). Transformers in the housing permit a decentralized installation. This decreases the power loss in the control cabinet.

If transformers are built into the housing, then the surface of the housing limits the acceptable loss of power. DST ... /G/ type transformers have been especially constructed with a high level of protection for operation within the housing. See section 3.8 for available options.

3.6. DST Three-Phase Autotransformers for Mounting in Control Enclosures

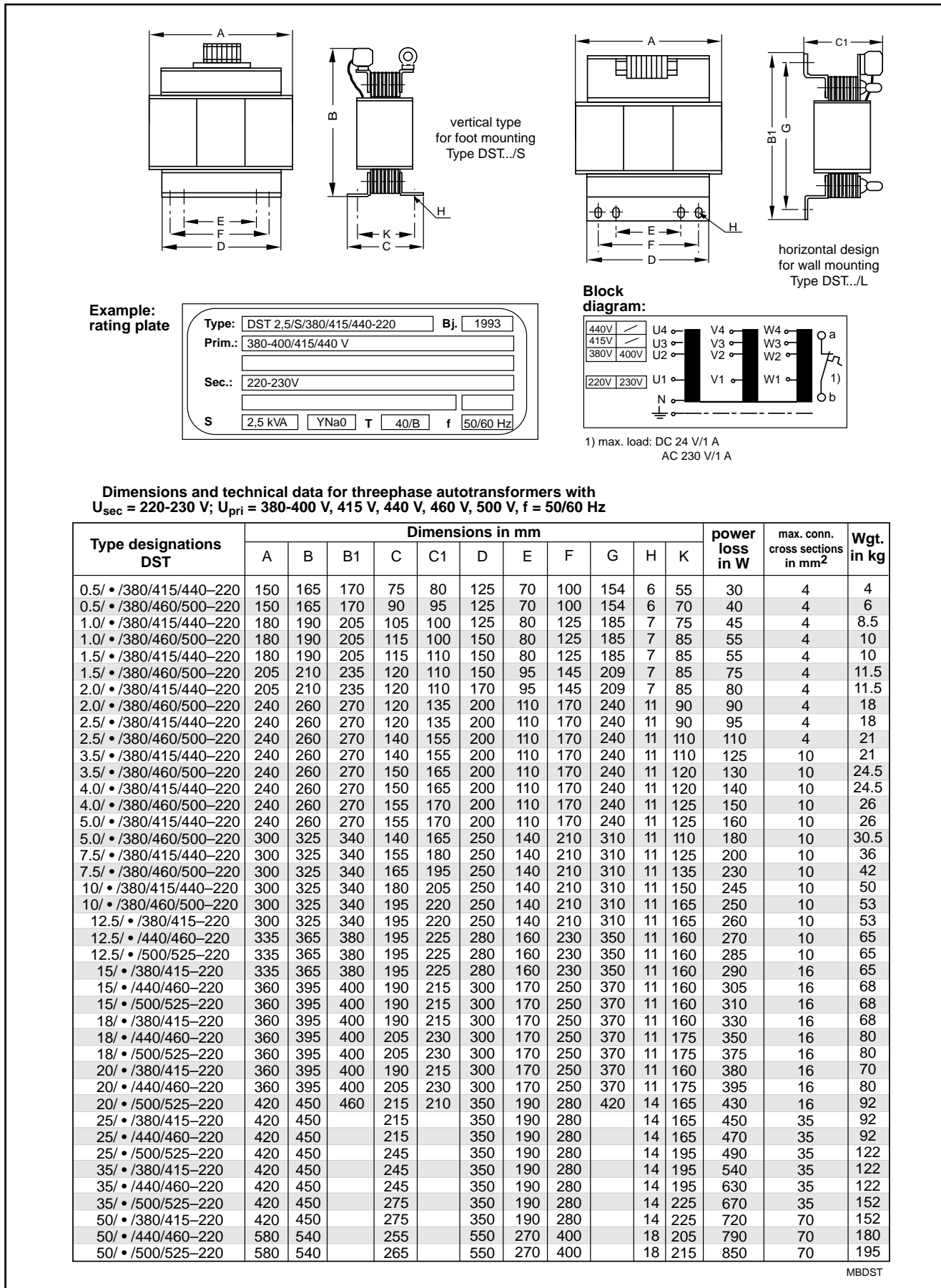

Fig. 3.5: DST - threephase autotransformers dimensional data

3.7. DLT Three-Phase Isolating Transformers for Mounting in Control Enclosures

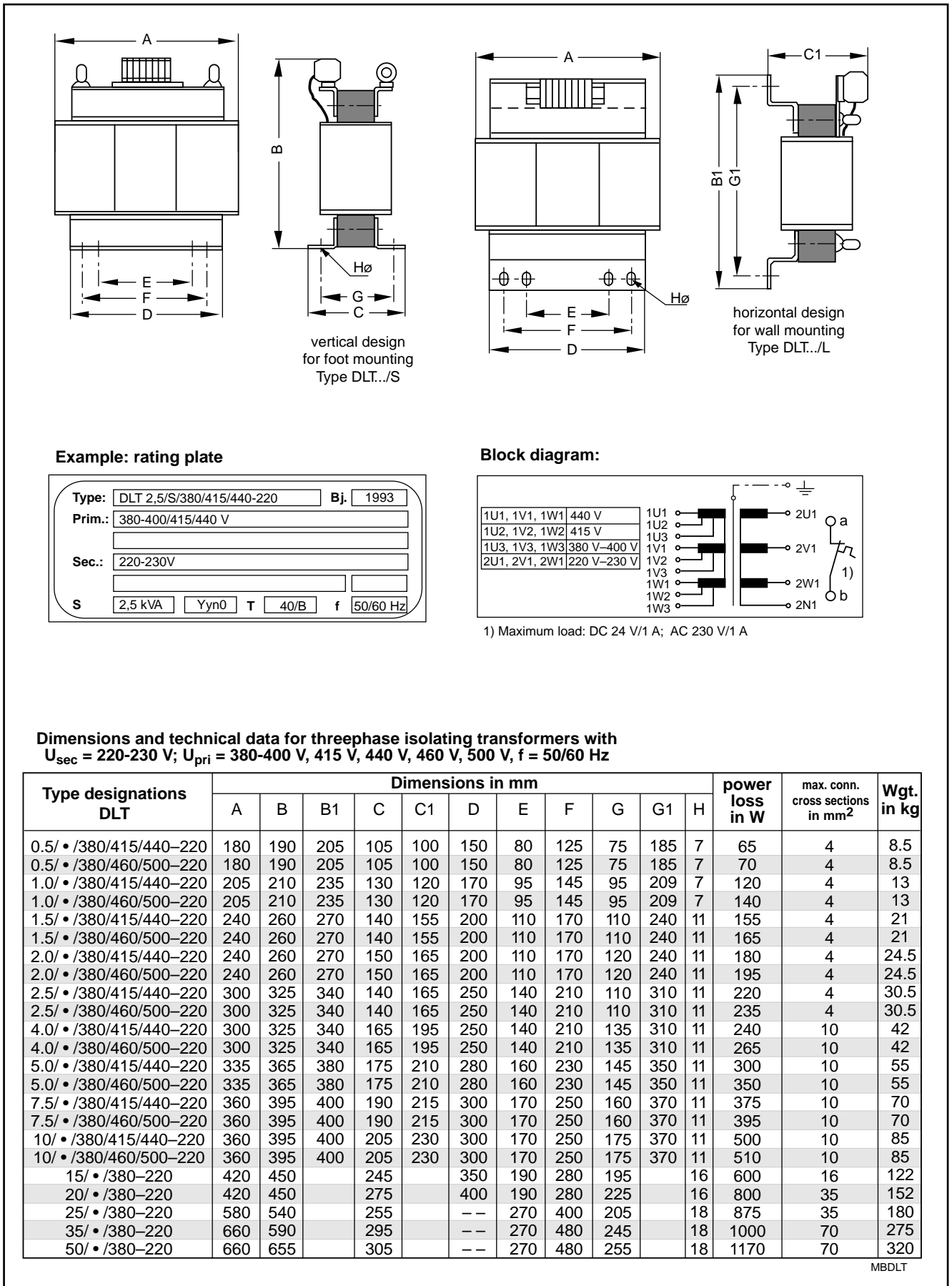
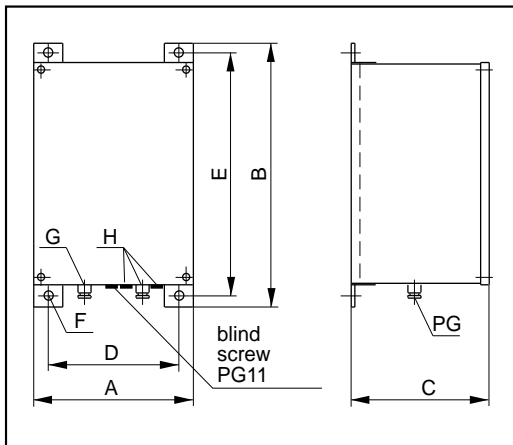

Fig. 3.6: DLT - threephase isolating transformers dimensional data

3.8. Three-Phase Autotransformers in IP 55 Housing

If transformers are to be mounted into housing, then this must be taken into consideration during planning. Due to the limit heat dissipation via the relatively small housing surface it is possible for standard transformers to reach unacceptably high temperature levels. Transformers of the type DST../G/ have been especially with a higher protection level for mounting into housing.



autotransformers with housing up to 5 kVA

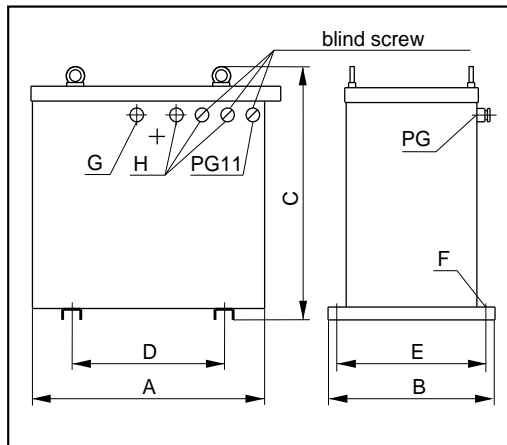

autotransformers with housing from 10 to 25 kVA

Technical data

as per DIN/VDE 0550 and 0532
 steel plate housing - prot. category IP 55
 powder coating in RAL 7032
 connection symbol: YNa0
 frequency: 50/60 Hz
 insulation class: T 40/F
 temperature contact: AC1A/250V/DC24V
 Resin coat for protection against corrosion
 individual items checked by VDE/IEC

Type codes

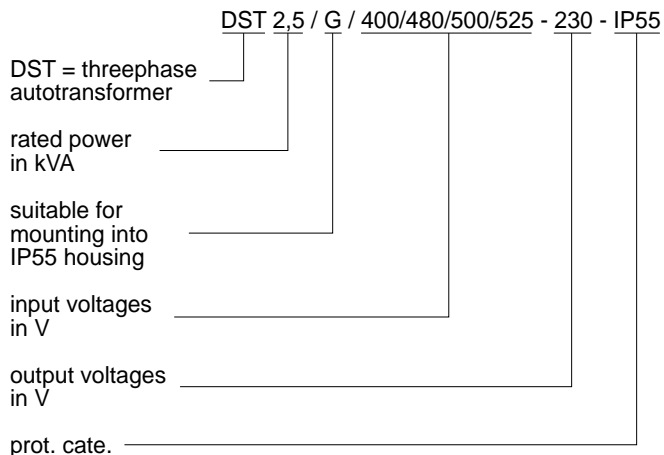

Block diagram

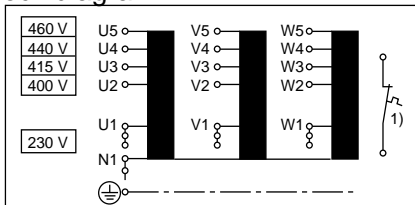

1) max. load: DC 24 V / 1 A
 AC 230 V / 1 A

Available types

Type Codes DST ../G/	Dimensions in mm						G Pg cable ø	H Pg cable ø	Weight in kg	Maximum conn. cross sections in mm ²
	A	B	C	D	E	Fø				
2,5/G/400/415/440/460-230-IP55 2.5/G/400/480/500/525-230-IP55	300	445	235	250	415	12	16 10...14	21 14...18	33.5	4
5.0/G/400/415/440/460-230-IP55 5.0/G/400/480/500/525-230-IP55	375	570	235	300	540	12	16 10...14	21 14...18	54	10
10/G/400/415/440/460-230-IP55 10/G/400/480/500/525-230-IP55	490	400	500	250	370	16	16 10...14	21 17...19	100	10
15/G/400/415/440/460-230-IP55 15/G/400/480/500/525-230-IP55	595	480	600	280	440	16	21 14...18	29 18...25	135	16
25/G/400/415/440/460-230-IP55 25/G/400/480/500/525-230-IP55	595	480	600	280	440	16	29 18...25	36 25...33	200	35

Fig. 3.7: Dimensions and data of 3-phase autotransformers (prot. cat. IP 55)

3.9. Motor Power Connection

Ready-made cables

Ready-made cables are available for motor power connections. The motor power cable can be made available in individual parts upon request.

Maximum cable length

If INDRAMAT motor power cables are used, then maximum cable length is 75 meters.



When operating the DDC 1.2 in residential and light-industrial areas, it may be necessary to shield the motor power cable to maintain the values for radio interference transmission (rf interference suppression).

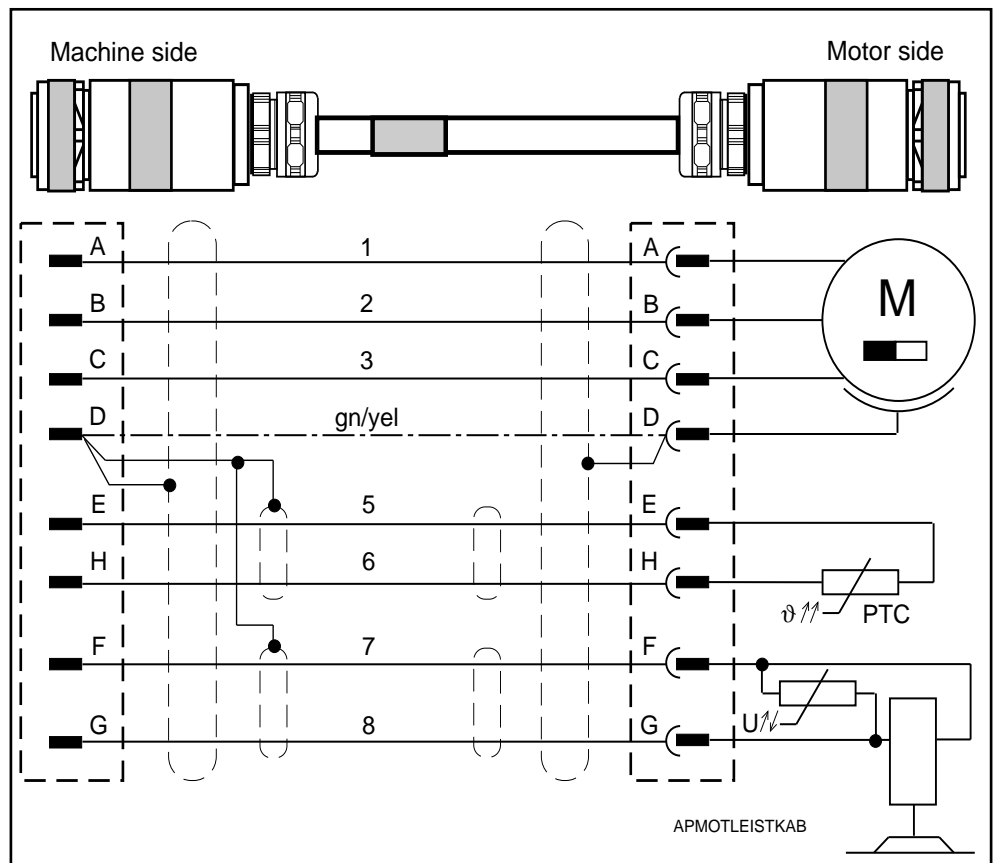

Fig. 3.8: A shielded motor power cable



The motor power connector controls the holding brakes of the MDD motors. The holding brake has not been designed to function as a working brake. It wears down after approximately 20,000 revolutions against the closed brake.

Motor power cable capacity

The following recommended cable types and cross sections are based on the current load capacity listed per EN 60 204 (VDE 0113) – E mode of installation.

If other standards are required for the actual application, or if cables are routed to accommodate a different installation mode, then greater cable cross sections may be needed.

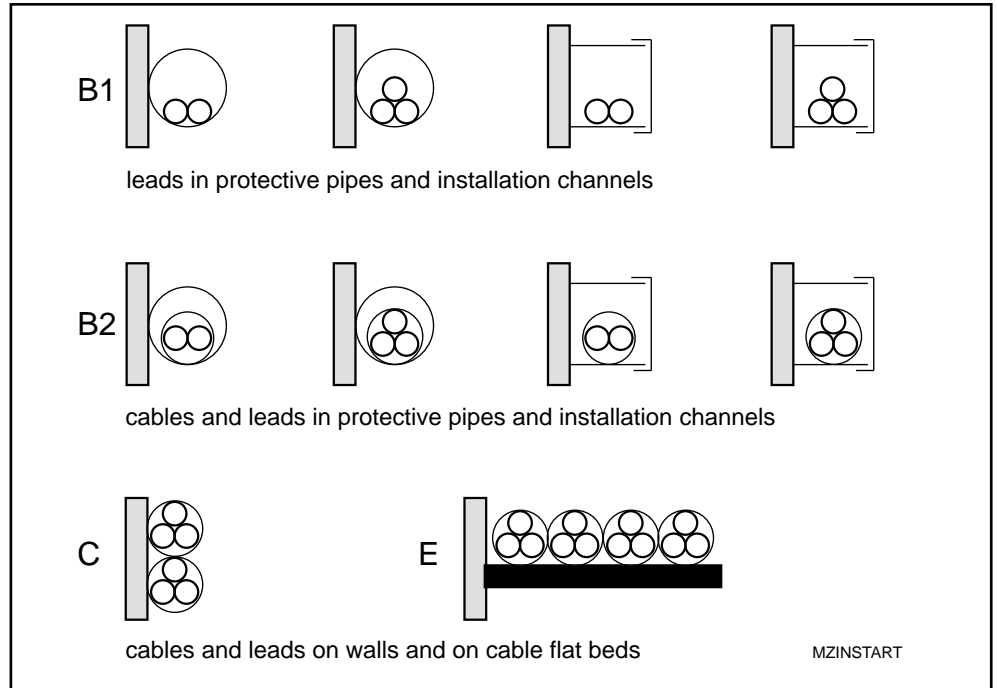

Fig. 3.9: Modes of installation as per EN 60204

cross sections in mm ²	Current load as per EN 60 204 in A			
	Installation mode B1	Installation mode B2	Installation mode C	Installation mode E
1.5	13.5	12.2	15.2	16.1
2.5	18.3	16.5	21	22
4	25	23	28	30
6	32	29	36	37
10	44	40	50	52
16	60	53	66	70
25	77	67	84	88

Recommended INDRAMAT Motor Power Cables

Motor type MDD...	DDC 1.2	connector on motor INS 3)	connector on unit INS 3)	INDRAMAT Cable for Motors Without Cooling			
				motor phase current in A	cross sections in mm ²	individual parts 1) INK2... INK6...	ready made IK. ... 2)
21...	-N050C	252	110	max.1.3	1.5	250	027
25...		252	110	max.3.2	1.5	250	027
41...		252	110	max.8.4	1.5	250	027
65A-N-040		252	110	1.5	1.5	250	027
65A-N-060		252	110	2.1	1.5	250	027
65B-N-040		252	110	2.9	1.5	250	027
65B-N-060		252	110	4.8	1.5	250	027
65C-N-040		252	110	4.5	1.5	250	027
65C-N-060		252	110	6.4	1.5	250	027
65D-N-040		252	110	5.2	1.5	250	027
65D-N-060		252	110	8.4	1.5	250	027
71A-N-030	-N050C	252	110	3	1.5	250	027
71A-N-040		252	110	4.1	1.5	250	027
71A-N-060		252	110	6.1	1.5	250	027
71B-N-030		252	110	6	1.5	250	027
71B-N-040		108	110	9	1.5	250	024
71B-N-060		108	110	12.3	1.5	250	024
71C-N-030		108	110	8.8	1.5	250	024
71C-N-040		108	110	12	1.5	250	024
71C-N-060	108	110	18	2.5	202	044	
90A-N-020	-N050C	252	110	3.3	1.5	250	027
90A-N-030		252	110	5.1	1.5	250	027
90A-N-040		252	110	7.7	1.5	250	027
90B-N-020		252	110	6.8	1.5	250	027
90B-N-030		108	110	10.3	1.5	250	024
90B-N-040		108	110	13.7	1.5	250	024
90C-N-020		108	110	9.8	1.5	250	024
90C-N-030		108	110	15.9	1.5	250	024
90C-N-040		108	110	19.9	2.5	202	044
93A-N-020	-N050C	108	110	8.3	1.5	250	024
93A-N-030		108	110	14.5	1.5	250	024
93A-N-040		108	110	19	2.5	202	044
93B-N-020		108	110	13.8	1.5	250	024
93B-N-030		108	110	19.6	2.5	202	044
93C-N-020		108	110	17.5	2.5	202	044
93C-N-030		108	110	26.3	4	203	064
112A-N-015	-N050C	108	110	6.8	1.5	250	024
112A-N-020		108	110	9.7	1.5	250	024
112A-N-030		108	110	14.1	1.5	250	024
112A-N-040		108	110	18.8	2.5	202	044
112B-N-015		108	110	12.1	1.5	250	024
112B-N-020		108	110	17	2.5	202	044
112B-N-030		108	110	22.9	4	203	064
112C-N-015		108	110	18.2	2.5	202	044
112C-N-020		108	110	24.3	4	203	064
112D-N-015		108	110	24.2	4	203	064
115A-N-015	-N050C	108	110	17	2.5	202	044
115A-N-020		108	110	22.7	4	203	064
115A-N-030		108	110	22.1	4	203	064

1) INK 2.. for standard, individual cable parts, INK 6.. for individual, shielded cable parts.

2) IKL... for standard, ready made cables, IKG... for shielded, ready-made cables.

3) For a complete list of all connector types see "Connecting accessories for INDRAMAT drives".

Recommended INDRAMAT Motor Power Cables

Motor type MDD...	DDC 1.2	connector on motor INS 3)	connector on unit INS 3)	INDRAMAT Cable for Motors With Cooling			
				motor phase current in A	cross sections in mm ²	individual parts 1) INK2... INK4...	ready made IK. ... 2)
71B-N-040	-N...A	108	217	9	2.5	202	050
71B-N-060		108	217	12.3	2.5	202	050
71C-N-030		108	217	8.8	2.5	202	050
71C-N-040		108	217	12	2.5	202	050
71C-N-060		108	217	18	2.5	202	050
90B-N-030	-N...A	108	217	10.3	2.5	202	024
90B-N-040		108	217	13.7	2.5	202	024
90C-N-020		108	217	9.9	2.5	202	024
90C-N-030		108	217	15.9	2.5	202	024
90C-N-040		108	217	19.9	2.5	202	044
93A-N-020	-N...A	108	217	8.3	2.5	202	050
93A-N-030		108	217	14.5	2.5	202	050
93A-N-040		108	217	19	2.5	202	050
93A-N-060		172	217	30.1	6	204	103
93B-N-020		108	217	13.8	2.5	202	050
93B-N-030		108	217	19.6	2.5	202	050
93B-N-040		172	217	29.9	6	204	103
93B-N-060		172	217	38.2	10	205	123
93C-N-020		108	217	17.5	2.5	202	050
93C-N-030		108	217	26.3	4	203	068
93C-N-040		172	217	37	10	205	123
93C-N-060		172	217	53.2	16	206	143
112A-N-015		-N...A	108	217	6.8	2.5	202
112A-N-020	108		217	9.7	2.5	202	050
112A-N-030	108		217	14.1	2.5	202	050
112A-N-040	108		217	18.8	2.5	202	050
112B-N-015	108		217	12.1	2.5	202	050
112B-N-020	108		217	17	2.5	202	050
112B-N-030	108		217	22.9	4	203	068
112B-L-030	172		217	22.9	6	204	103
112B-N-040	172		217	33.9	6	204	103
112C-N-015	108		217	18.2	2.5	202	050
112C-N-020	108		217	24.3	4	203	068
112C-L-020	172		217	24.3	6	204	103
112C-N-030	172		217	35.4	6	204	103
112C-N-040	172		217	47.5	10	205	123
112D-N-015	108		217	24.2	4	203	068
112D-L-015	172		217	24.2	6	204	103
112D-N-020	172		217	35.8	6	204	103
112D-N-030	172	217	49.5	10	205	123	
115A-N-015	-N...A	108	217	17	2.5	202	050
115A-N-020		108	217	22.7	4	203	068
115A-L-020		172	217	22.7	6	204	103
115A-N-030		172	217	34.6	6	204	103
115B-N-015		108	217	22.1	4	203	068
115B-L-015		172	217	22.1	6	204	103
115B-N-020		172	217	34.6	6	204	103
115B-N-030		172	217	66.8	16	206	143
115C-N-015		172	217	32.8	6	204	103
115C-N-020		172	217	42.1	10	205	123
115C-N-030		172	217	62.9	16	206	143
115D-N-015		172	217	31.5	6	204	103
115D-N-020		172	217	62.9	16	206	143

1) INK 2.. for standard, individual cable parts, INK 6.. for individual, shielded cable parts.

2) IKL... for standard, ready made cables, IKG... for shielded, ready-made cables.

3) For a complete list of all connector types see "Connecting accessories for INDRAMAT drives".

3.10. Motor Feedback Connection

Feedback Connection

The feedback connections for motors with digital servo feedback (DSF) and resolver feedback (RSF) are built into cable leadthroughs inside the DDC 1, at terminal X4 (see section 4). Ready-made cables are also available.



MDD motors with digital servo feedback can only be operated with DDC 1.2-.....-D...-XX and motors with resolver feedback only with DDC 1.2-.....-R...-XX units.



Only those motor/drive combinations listed in the configuration sheets may be operated together.

Maximum cable length

Maximum cable length is 75 meters if INDRAMAT feedback cables are used.

Connector assignments for DSF and RSF

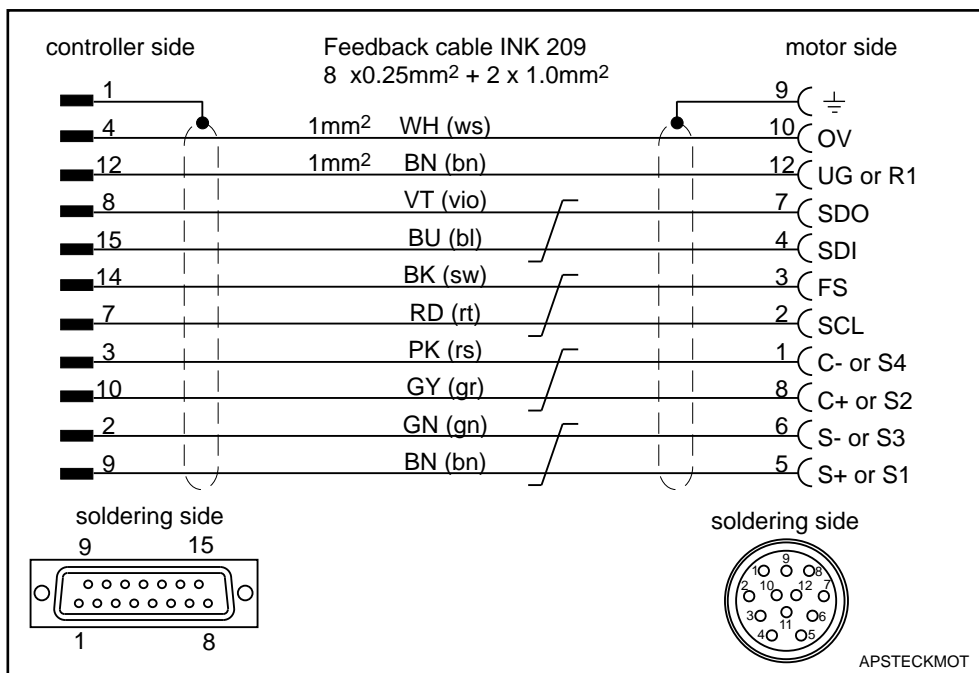

Fig. 3.10: Motor feedback terminal assignments

Ready-made INDRAMAT feedback cables for MDD motors

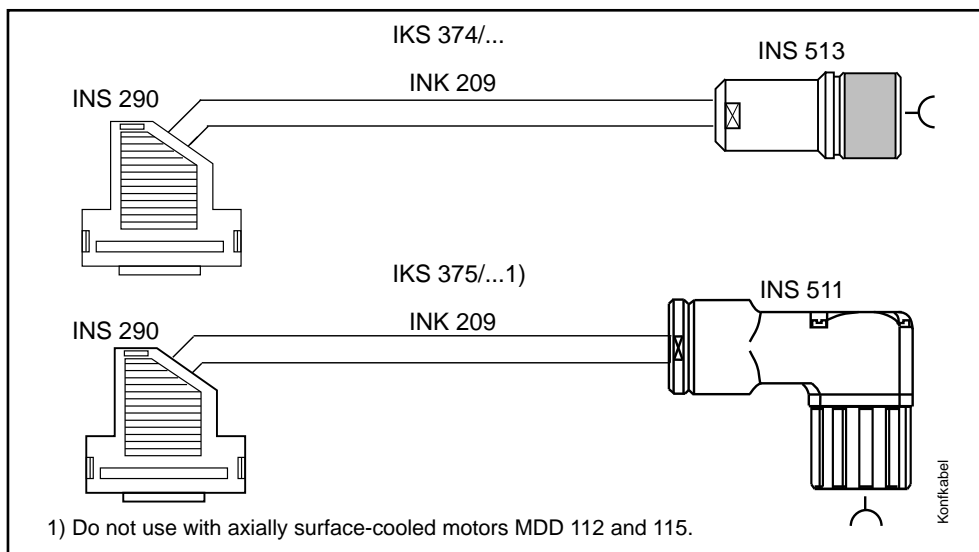

Fig. 3.11: Ready-made INDRAMAT feedback cables

3.11. Interface to NC Control Unit

Ready-made cable Interface X8 connects the DDC to the machine control unit. Ready-made cable, IKS083, is available for this purpose.

Maximum cable length Maximum cable length is 20 meters if ready-made cable IKS 083 is used.

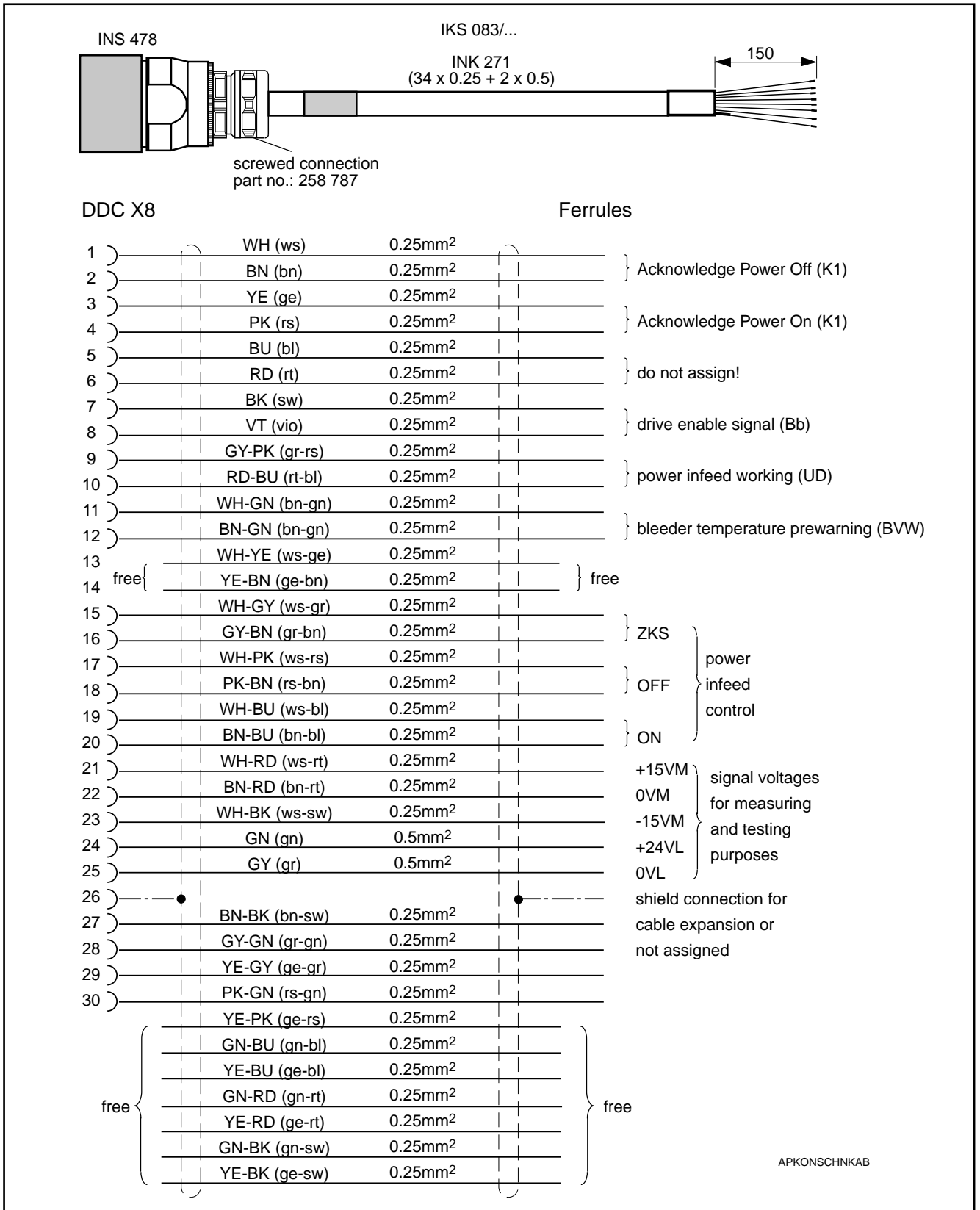

Fig. 3.12: Ready-made interface cable IKS 083

3.12. Control Circuit of the DDC Mains Contactor

The general operating method as suggested by INDRAMAT is to control the mains contactor and dynamic braking in the DDC. Selection of the control method and its effects will depend on the functions offered and the responses of the entire system. It is, therefore, the responsibility of the machine builder.

Standstill with fault in drive electronics with/without DC bus dynamic braking

With dynamic braking, synchronous motors are always braked to a standstill (MAC or MDD) whether electronic circuitry in the drive is still operational or not. The dynamic brake functions as an **additional protective device** for the machine.

Inductance motors (2AD or 1MB) are not braked when the DC bus is short-circuited.

Without dynamic braking, properly functioning drives can be braked at maximum torque. However, if there is trouble in the closed-loop electronic control system or if there is a discontinuity in the feedback line, it should be expected that drives will coast without electrical braking. Dynamic braking can only be eliminated when non-braked deceleration does not damage the system. As an alternative, motors equipped with mechanical holding brakes can be used.



How to stop the drive in the event of a fault will depend on the functions offered on the system. In the final analysis, this decision can only be reached by the system designer. Thus, the following recommended is intended only as a guide to the system designer.

3.13. Control Circuit in the DDC with Dynamic Braking

Application This control circuit should be selected if a synchronous motor, e.g., MDD, is connected to the DDC.

Features Dynamic braking always brakes synchronous motors to a standstill whether or not the drive electronics are operational. The DC bus is only short-circuited with a drive fault.

In the event of an emergency stop (E-stop) or a disconnect, the drives are braked to a standstill at maximum torque by the drive electronics.

Operating principle If the ON button is pressed, then auxiliary relays K3 and K4 switch mains contactor K1 on. Should K3 or K4 fail, then power cannot be switched on.

If the E-stop button is pressed, then K3 and K4 safely switch off mains contactor K1. The NC control unit of the machine must simultaneously lock out the **drive enable** (RF input with analog interface, E-STOP input of a DEA with a DLC single axis positioning module). The command value of the drive is then switched to zero. There is a controlled braking of the drive.

A drive error signal from the Bb contact of the DDC, an error signal from the controller (servo error) or an overtravelling of the limit switch disconnects the mains contactor and triggers dynamic braking.

The signal sequence as depicted in the diagram below is recommended for commissioning the DDC.

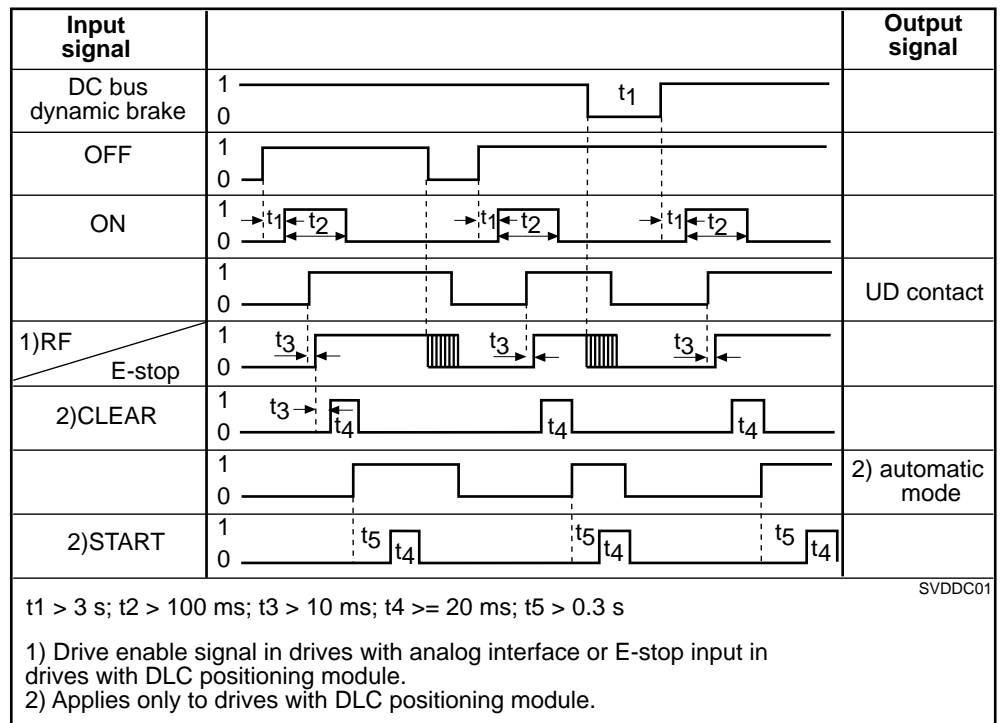

Fig. 3.13: Signal path diagram for switching on a DDC

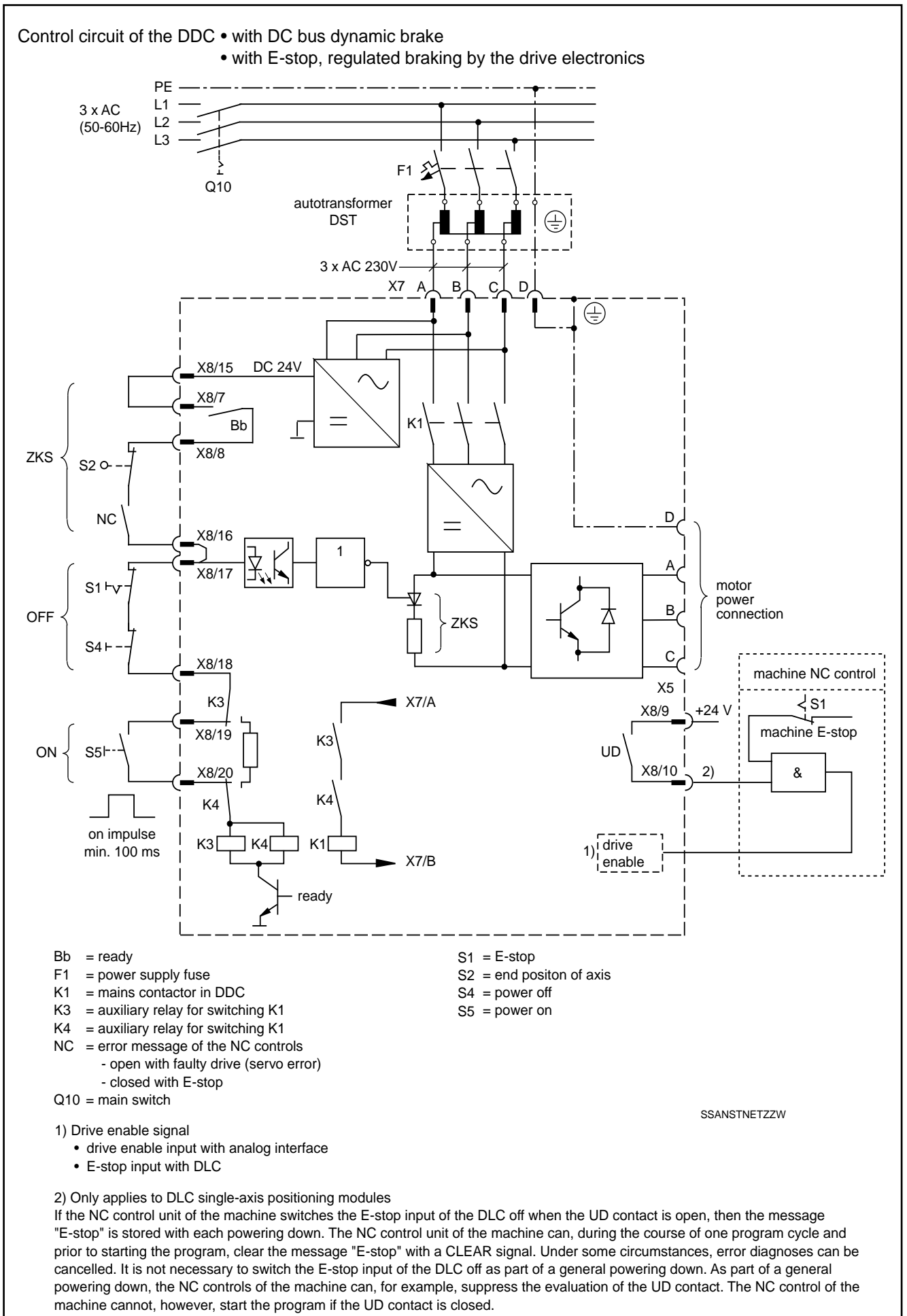

Fig. 3.14: Control circuit of the DDC mains contactor with dynamic brake

3.14. Control circuit of the DDC Mains Contactor Without Dynamic Braking

- Application*
- if an inductance motor is mounted to a DDC (2AD; 1MB; LAF; LAR)
 - if uncontrolled coasting cannot damage the installation.

Features The DC bus is not short-circuited. There can be no controlled braking of inductance drives if the DC bus is short-circuited.

The drives are braked by the drive electronics at maximum torque for an E-stop or a power disconnect.

Operational principle If the E-stop sequence is triggered, then K3 and K4 safely switch off mains contactor K1. The NC control unit of the machine simultaneously locks out the **drive enable** (RF input with analog interface, E-stop input of a DEA with a DLC single-axis positioning module). The command value of the drive is switched to zero. There is a controlled braking of the drive.



The drives coast uncontrolled with a fault in the drive electronics. The short circuiting of the DC bus can only be dispensed with if a coasting of the drives cannot damage the facility. Motors with mechanical holding brakes can be used as an alternative.

The signal sequence depicted in the diagram below is recommended.

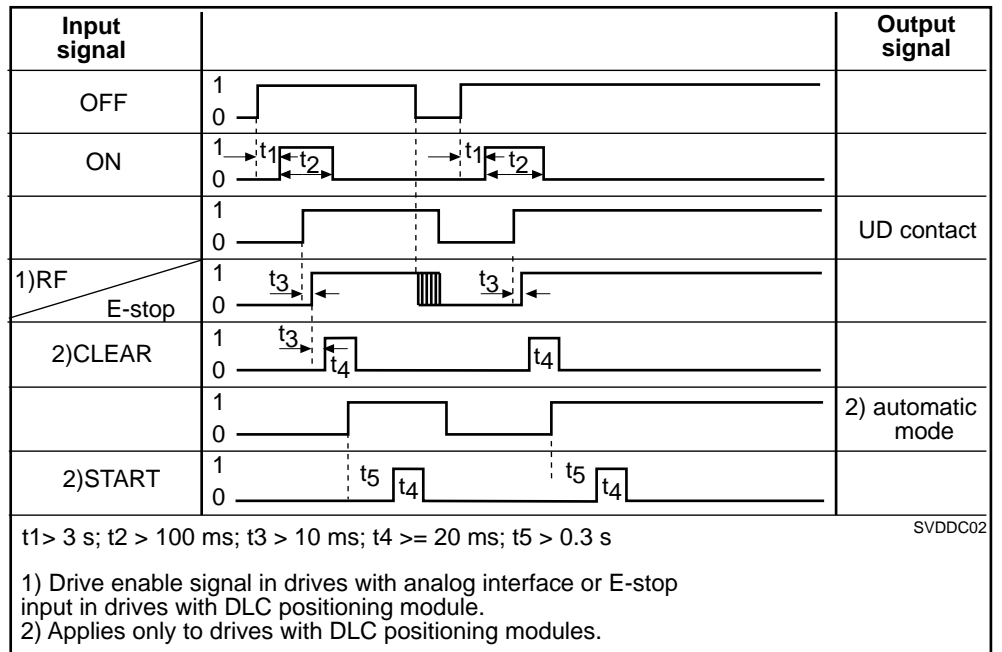

Fig. 3.15: Signal path diagram for switching on a DDC

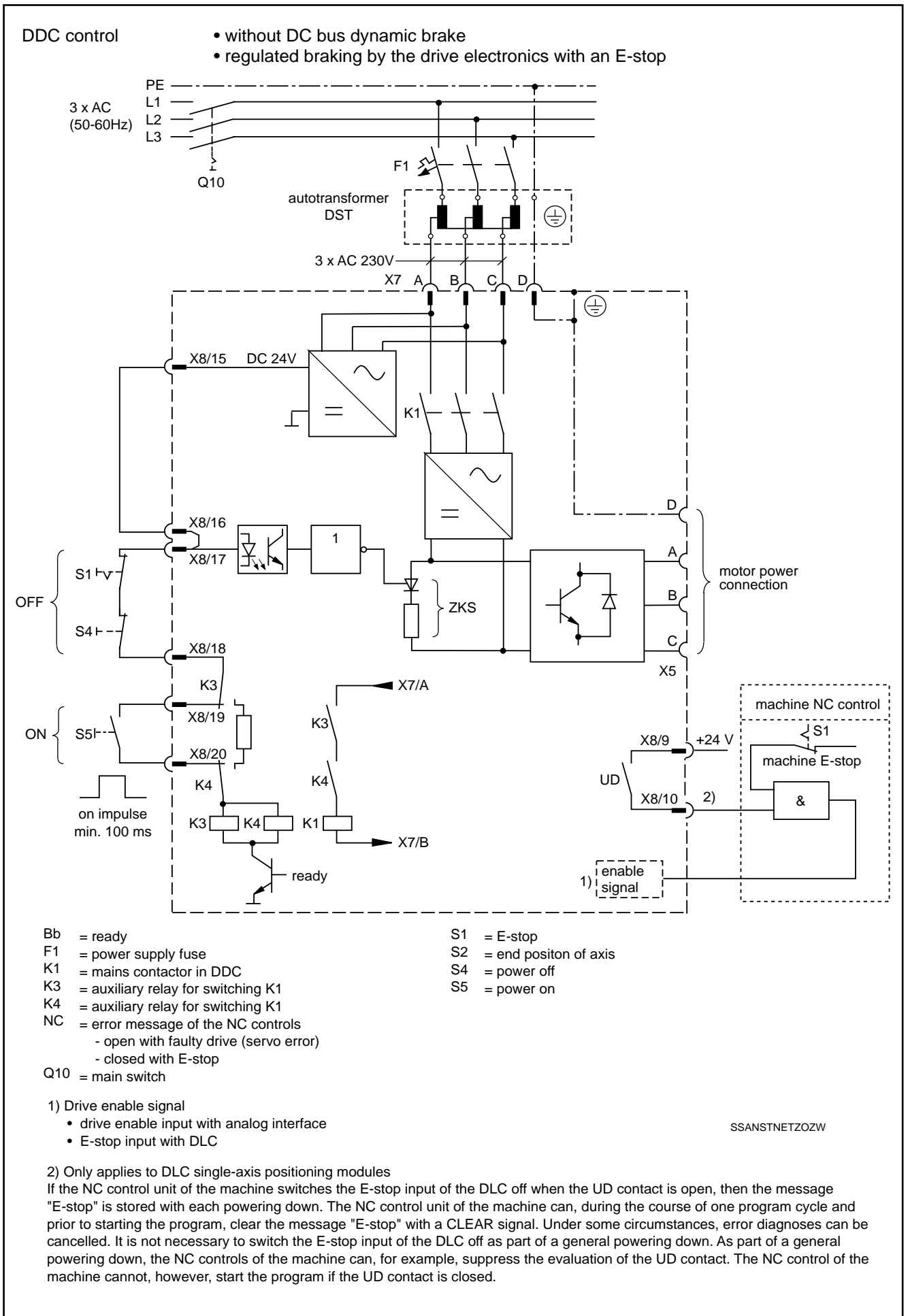

Fig. 3.16: Control circuit of the mains contactor in a DDC without dynamic braking

3.15. Control Circuit of the DDC Mains Contactor with E-Stop Relays

- Application*
- if several E-stop switches are needed in larger installations or if, e.g., a safety door monitor is required or
 - if a synchronous motor (MDD) is connected to the DDC.

Features Dynamic braking always brakes synchronous motors to a standstill whether or not the drives electronics are operational. The DC bus is only **short-circuited if there is a drive fault**.

In the event of an emergency stop (E-stop) or a disconnect, the drives are **braked to a standstill at maximum torque by the drive electronics**.

Operating Principle If the ON button is pressed, then K3 and K4 safely switch on mains contactor K1. Should K3 or K4 fail, then power cannot be switched on.

If the E-stop button is pressed, then K3 and K4 safely switch off mains contactor K1. The NC control unit of the machine must simultaneously lockout the **drive enable** (RF input with analog interface, E-stop input of a DEA 3 with DLC single-axis positioning module). The command value of the drive is then switched to zero.

A drive error signal from the Bb contact of the DDC, an error signal from the controller (servo error), or an overtravelling of the limit switch disconnects the mains contactor and triggers dynamic braking.

The signal sequence as depicted in the diagram below is recommended for commissioning the DDC.

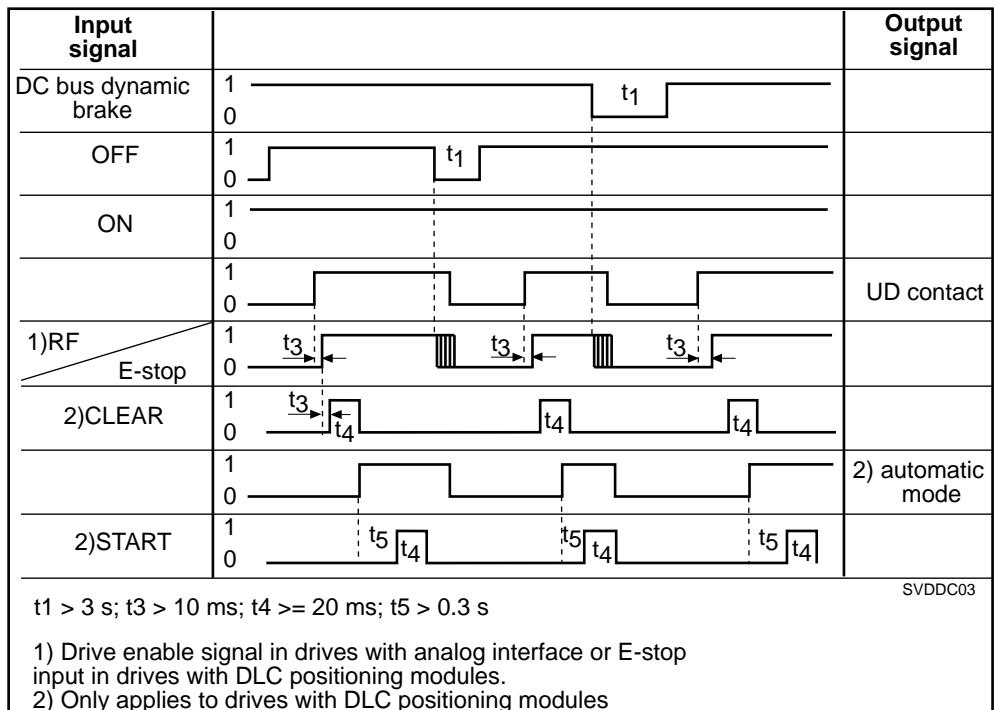

Fig. 3.17: Signal path diagram for switching on a DDC

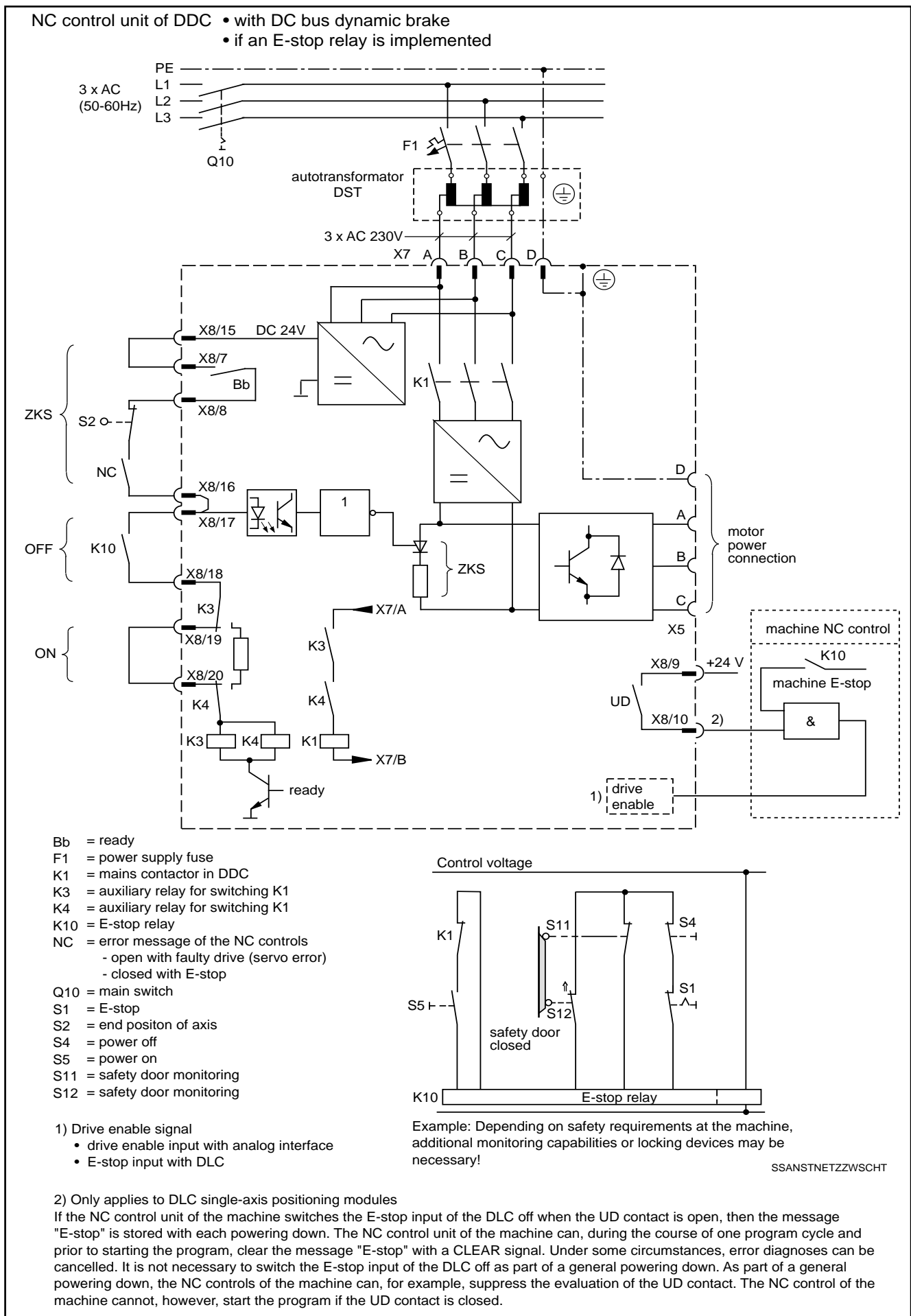

Fig. 3.18: DDC mains contactor with dynamic brake and safety door monitor

3.16. Control Inputs

DC bus dynamic brake Connector: X8/15-X8/16
Voltage: 24V DC
Current consumption: 150 mA

Input ZKS	open	closed
Operating state	Power OFF DC bus dynamic braking active	Power ON DC bus dynamic braking not active

The mains contactor on a DDC cannot be turned on unless ZKS input is closed. As an additional feature, when trouble occurs in the electronic system of the drive, the drive can be braked to a stop by opening the ZKS input. This causes the bus voltage to shorted internally in the DKC. The DC bus dynamic brake is an additional machine protection.

Power OFF Connector X8/17-X8/18
Voltage: 24V DC
Current consumption: 150 mA

Input OFF	open	closed
Operating state	Power OFF	Power ON

Only when the input is closed can the mains contactor be activated. If the Off input is opened, e.g., with an E-stop, then the mains contactor on the DDC is turned off immediately. However, the internal bus is not shorted.

Power ON Connector X8/19-X8/20
Voltage: 24V DC
Current consumption: 150 mA

Input ON	open	closed or open and self-holding closed
Operating state	Power OFF	Power ON

If the ZKS and the OFF inputs are closed and the device is ready, closing the ON input will perform a soft start for the power section in the DDC. The mains contactor then goes to a self-holding state. The activating pulse must be present for approximately 100 ms.

3.17. Signal and Diagnostics Outputs

Ready state Zero potential contact - Connector X8/7-X8/8
Maximum load: DC 24V/1A (do not attach higher voltages!)

Operating state	Relay power off	Error	ready
Output Bb	open	open	closed

The Bb contact signals that the drive is ready for powering up. Internal interlocking devices will not permit the mains contactor in the DDC to be turned on until it is closed. The mains contactor is deactivated and the Bb contact opened with an error. Once the Bb contact opens, there can be no controlled deceleration of the drives. It can, therefore, be used to trip the dynamic brake.

DC bus voltage working Zero potential contact - Connector X8/9-X8/10
Maximum load: DC 24V/1A
AC 250V/1A

Operating state	Relay power off	Error	Power working
Output UD	open	open	closed

The UD contact is closed if the DC bus voltage is greater than 200 V and the mains contactor is turned on.

The UD contact can be used as a prerequisite for releasing the feed function.

Bleeder Prewarning Zero potential contact - Connector X8/11-X8/12
Maximum load: DC 24V/1A
AC 250V/1A

Operating state	Relay power off	Bleeder load too high	Bleeder load within permissible limits
Output BVW	open	open	closed

The bleeder warning contact opens, if continuous regenerated power is greater than 75% of continuous bleeder power. Should the bleeder load continue to climb to thermal overload, then the power supply to the DDC is discontinued.

Mains contactor picked up Zero potential contact - Connector X8/3-X8/4
 Maximum load: DC 24V/10A
 AC 230V/6A

Operating state	contactor dropped	contactor picked up
Output Power ON	open	closed

It can be queried at output power ON whether the mains contactor has been switched on. The closed contact can be used as a condition for the drive enable signal.

Mains contactor dropped out Zero potential contact - Connector X8/1-X8/2
 Maximum load: DC 24V/10A
 AC 230V/6A

Operating state	contactor dropped	contactor picked up
Output Power OFF	closed	open

It can be queried at output OFF whether the mains contactor has dropped out. This information can, for example, be used as a condition to release the door locking device.

Analog diagnoses outputs AK1 and AK2 For diagnostics purposes, drive data can be output at analog outputs AK1 and AK2. Which drive quantities are output is determined at commissioning.

Output voltage: ± 10 V
 Load capacity: 4 mA

3.18. Signal Voltages

It is possible to tap off ± 15V and +24V at connector X8. These connections are specifically used for measuring and test purposes. Should these voltages be applied outside of the DDC, then no interference voltages may be coupled in (short and shielded supply lines).



The signal voltage outputs are short-circuit proof. Maximum load should not be exceeded, otherwise the drive could be damaged.

X8/21	+15VM	measuring voltage	max.100mA
X8/22	0VM	reference potential	
		measuring voltage	
X8/23	-15VM	measuring voltage	max.100mA
X8/24	+24VL	load voltage	max.100mA
X8/25	0VL	reference potential	
		+24VL	
X8/26	ground	shield	

3.19. Reading Drive Parameters

RS 232 Interface

A VT 100 terminal or a PC with a VT 100 emulation program can be connected at connector X2 via an RS 232 interface to a DDC drive with analog command value input or with a single-axis positioning module.

Drive parameters, such as amplification of velocity loops, can be output and optimized, if necessary, via these interfaces at the time of commissioning.

Fault diagnostics are displayed in plain text in the event that service is needed.

Ready-made service cable INK 391 is available for connecting the DDC to a PC (available lengths: 2, 5, 10 and 15 meters).

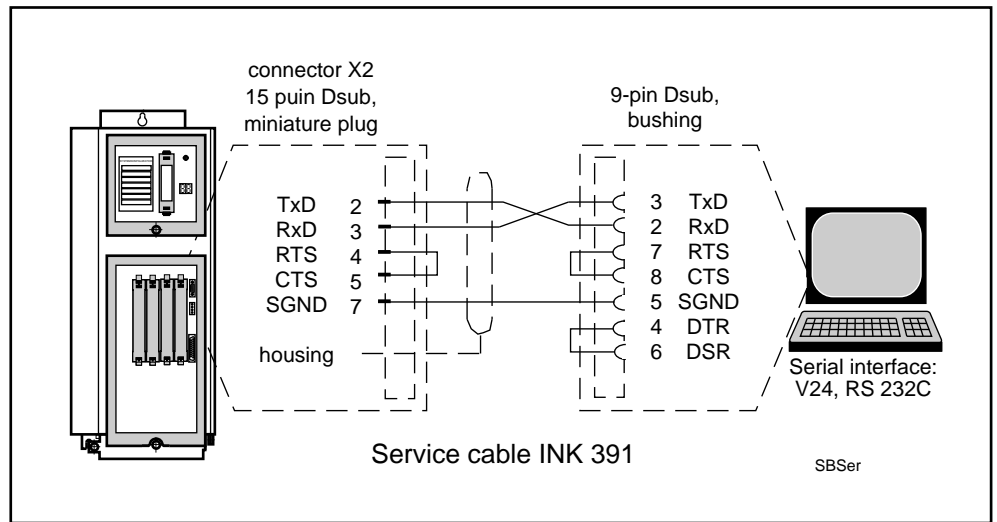

Fig. 3.19: RS 232 interface

3.20. Regenerated Power

During braking, the energy stored in the drive is absorbed by the bleeder in the DDC. Do not exceed continuous bleeder power. See data sheets for precise data.

Continuous bleeder power

Continuous bleeder power is dependent upon rotary drive energy, potential energy of unbalanced mass and the number of machine cycles completed.

$$P_{RD} = \frac{W_{rotg} + W_{potg}}{t_z}$$

PRD = continuous regenerated power or cont. bleeder power in kW
 t_z = cycle time in s
 W_{potg} = sum of potential energy in kW
 W_{rotg} = sum of rotary energy in kW



When operating main drives in particular (2AD and 1MB), check whether continuous bleeder power and maximum regenerated energy during braking are not exceeded -- as per the data sheets.

3.21. Fault Current Protective Device

Capacitive discharge currents always flow to earth in switch-mode drives.

The extent of the discharge current is dependent upon:

- the number of drives used,
- the length of the motor power cable,
- the motor type and
- the ground conditions at the installation site.

The discharge current is unavoidably increased, if measures are taken to improve the electromagnetic compatibility (EMC) of the machine (mains filters or shielded cables).

FI current limiting circuit breakers with a nominal fault current smaller than 0.3 A should **not** be used!

Switching inductors on, e.g., transformers, contactors or electromagnetic valves, can cause false tripping.



The safety of electronic equipment with three-phase bridge connections, B6 switches, cannot be guaranteed if commercial, pulse-current sensitive FI protective circuit breakers are used. For this reason, FI circuit breakers should not represent the only safety measures taken.

3.22. High-Voltage Testing

**Connect only those voltages outlined in the data sheets or in the interface descriptions.
Remove all connections to the DDC 1 before performing any high voltage checks.**

4. Mounting the DDC 1.2

The protection category of the DDC 1.2 is IP 65. It can be directly mounted to the feeding device. Long cable connections susceptible to interference are thus avoided.

4.1. DDC 1.2-N - dimensional data

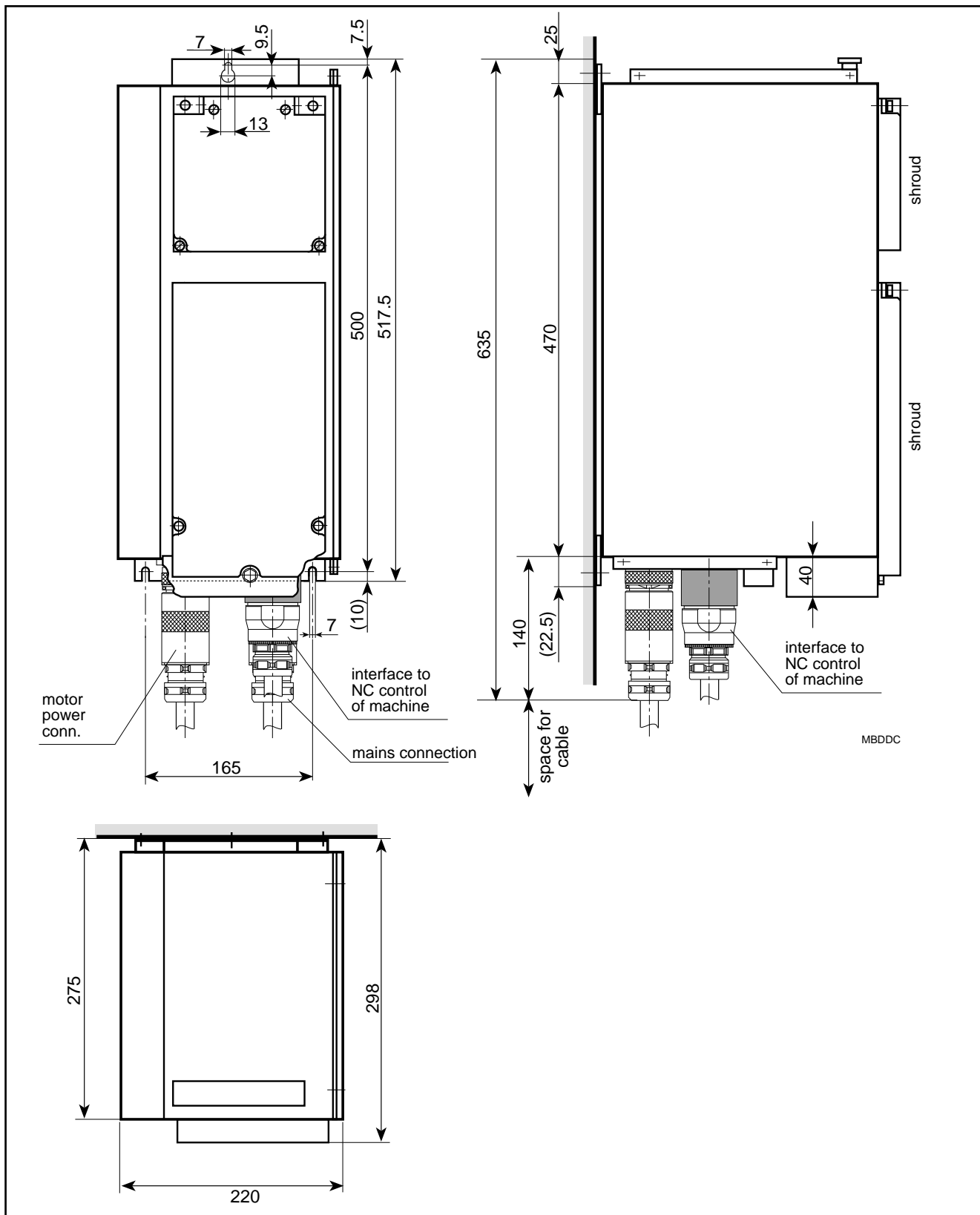

Fig. 4.1: DDC 1.2 - dimensional data

4.2. Front View of DDC 1.2-N

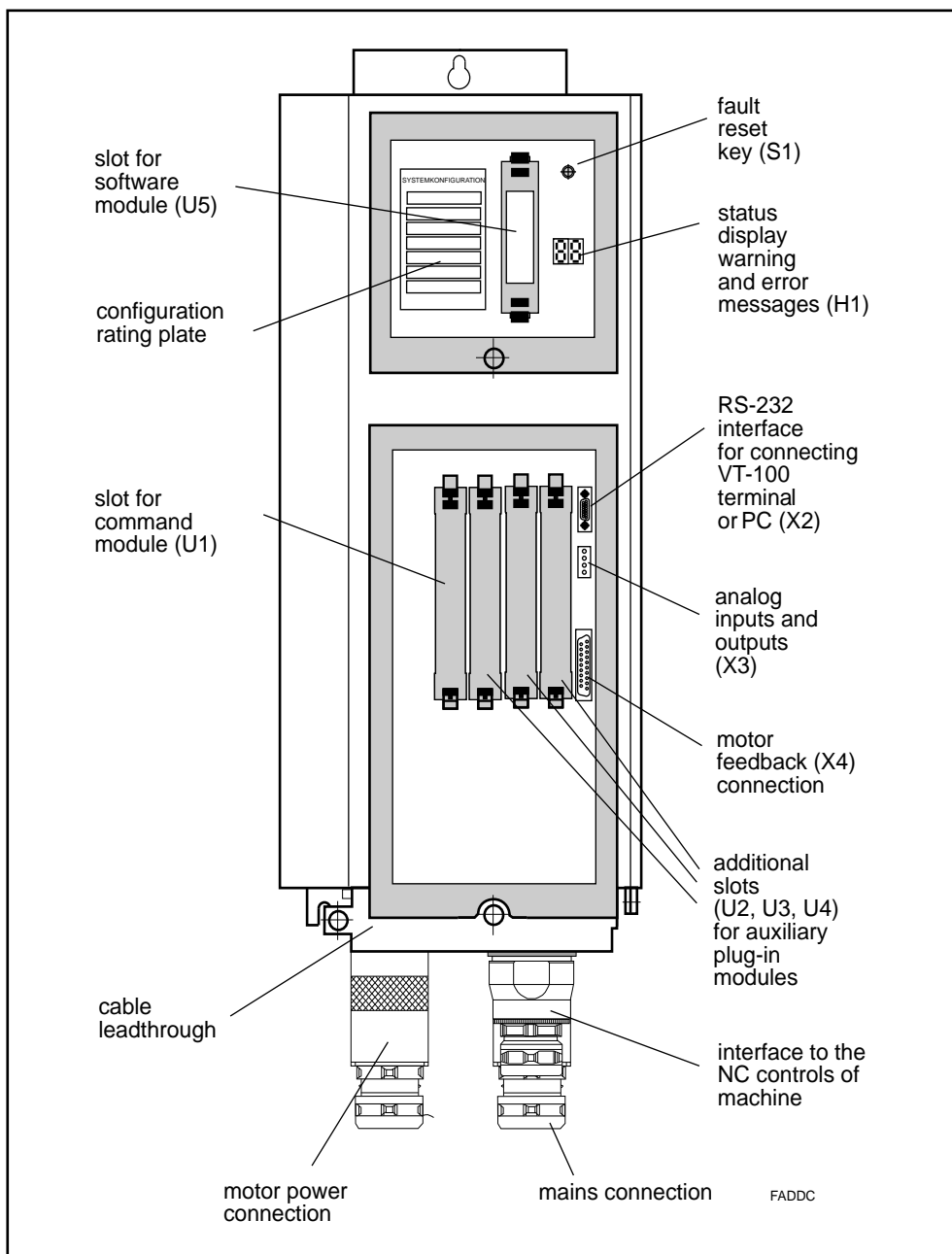

Fig. 4.2: Front view of DDC 1.2-N

4.3. Power Connections

The protection category of the power terminal connectors (X7) of the DDC, the motor power terminal (X5), and the NC control unit interface (X8) is IP 65.

The motor feedback cable and the connections for the optional plug-in cards are inserted in the DDC. These connections run through the cable leadthrough along the underside of the DDC. These must be carefully installed to maintain the IP 65 protection category.

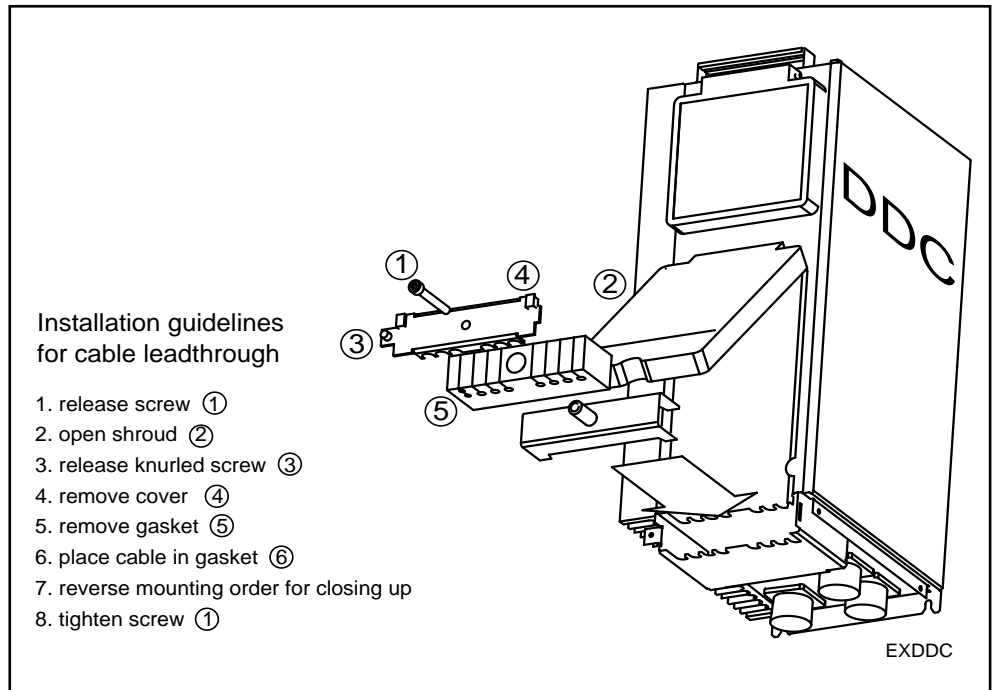

Fig. 4.3: Installing the cable leadthrough

4.4. Minimum Clearances

During installation, make sure that the air outlet is not obstructed and the bend radii of the cables are maintained.

Minimum clearance equals allowance for power connectors plus bend radius, but not smaller than 300 mm.

*Bend radii of
INDRAMAT cables*

Type	Power core diameter (mm ²)	Power cable diameter (mm)	Minimum Bend Radius	
			fixed routing (mm)	flexible routing ¹⁾ (mm)
INK 250	1.5	11.4 ± 0.4	70	110
INK 202	2.5	17.6 +0.3/-0.5	120	200
INK 203	4.0	18.6 ± 0.5	120	270
INK 204	6.0	20 ± 0.5	120	300
INK 205	10.0	25.4 ± 0.5	200	380
INK 206	16.0	26.6 ± 0.5	220	390
INK 207	25.0	30.6 ± 0.7	240	430
INK 650	1.5	12.2 ± 0.4	80	120
INK 602	2.5	14.8 ± 0.5	85	140
INK 603	4.0	16.9 ± 0.5	110	180
INK 604	6.0	18.8 ± 0.6	120	195
INK 605	10.0	23.8 ± 0.5	150	240
INK 606	16.0	28.2 ± 0.6	160	280
INK 607	25.0	29.5 ± 0.6	190	290

¹⁾ Service life greater than 500 000 bend loads.

Fig. 4.4: Bend radii of INDRAMAT cables

Safety Clearances The bleeder resistor in the DDC heats up during operation. Flammable materials or parts which could deform in the hot air stream, e.g., polyvinylchloride cable conduits, must maintain a minimum clearance of 300 mm to the air outlet.

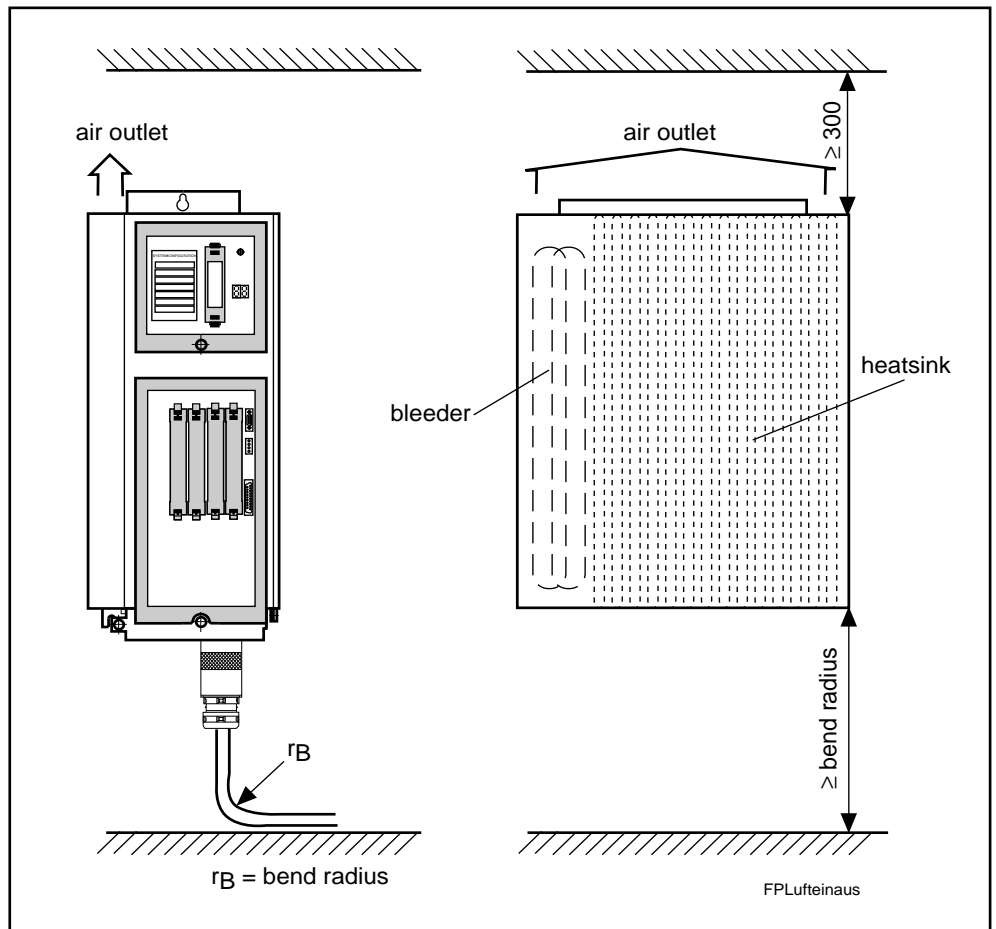

Fig. 4.5: DDC - air inlet and outlet and position of bleeder resistor



The DDC 1.2 generally needs no maintenance. If it is operated in a very dirty environment, and if heatsink could become clogged, e.g., by foundry dust, then these should be regularly checked. If the device function is inhibited by dirt, then both the blower and the heatsink should be cleaned.

5. Ordering Information

5.1. Type Codes for the DDC 1.2

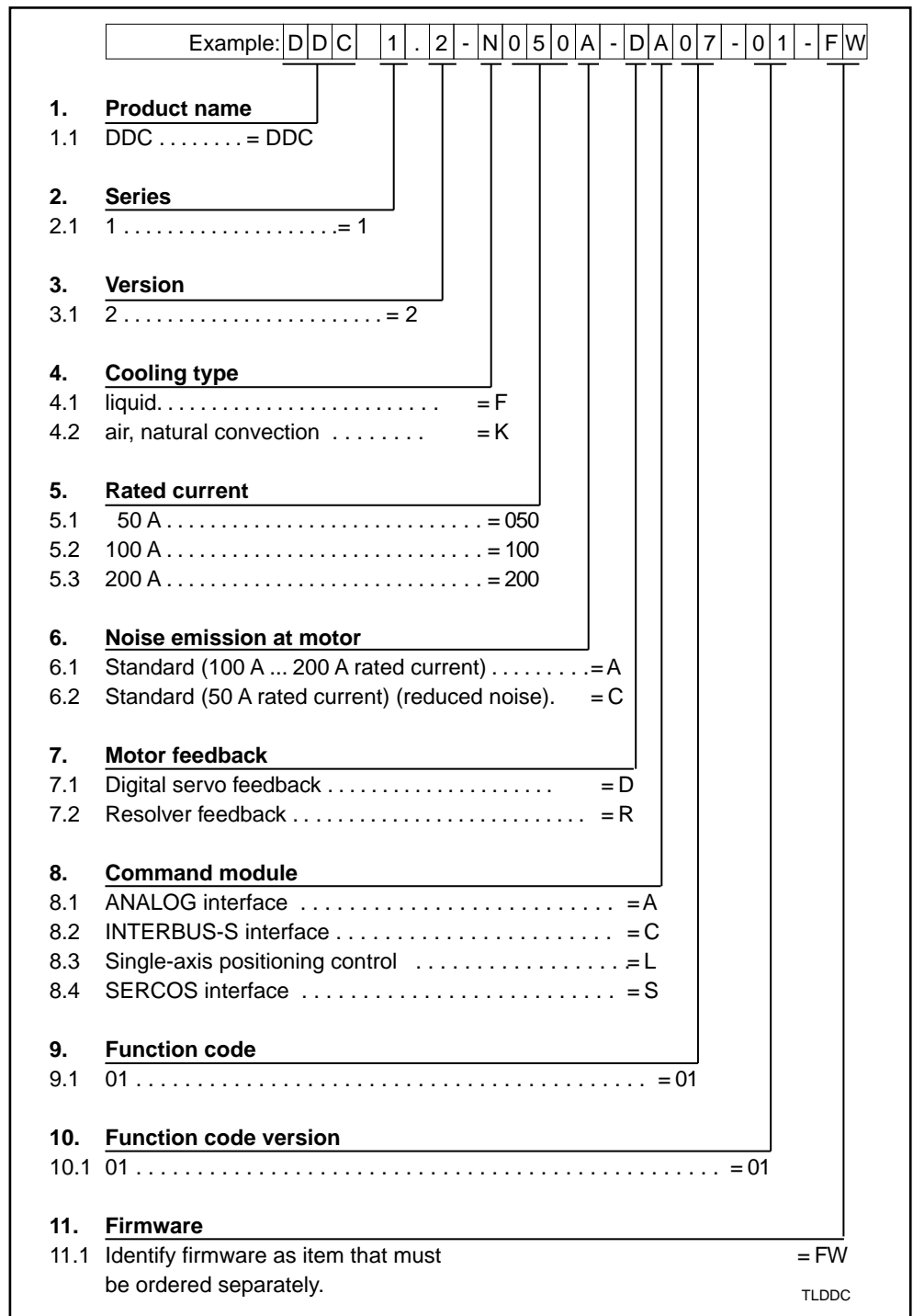

Fig. 5.1: DDC 1 - type codes

5.2. Accessories for Connections

The following connectors and connector sets are available where ready-made cables are not used.

Individual IP 65 connectors

IP 65 connectors are used for the power connections of the DDC, motor power cable connections and the NC control unit connections.

Name		Connector type
Power connection	DDC 1.2-N050C	INS 108/.. ¹⁾
	DDC 1.2-N ... A	INS 172/..
Motor power cable	DDC 1.2-N050C	INS 110/.. ²⁾
	DDC 1.2-N ... A	INS 217/..
Connection to machine NC control unit		INS 478

1) For complete types see 3.4

2) For complete types see 3.10

The plug-in module connections are inserted in the DDC 1. Select the relevant connector set (S..-DDS 2) after discussing your requirements with your INDRAMAT Sales Office.

5. Order Informationen

Individual connector sets If ready-made cable sets are only partially used, then the still required connectors for the plug-in modules can be ordered separately.

Components	Conn. strip	Name of plug-in connector	Part number	Text	Comment
DDS 2, DDS 3 drive controller	X4	plug-in connector for feedback conn., 15 pin Dsub, male	231 715	CONN. INS290	plug-in connector not needed with ready-made feedback cable
DKS 1 drive controller	X4	plug-in connector for feedback connection, 15 pin Dsub, male	231 715	CONN. INS290	plug-in connector not needed with ready-made feedback cable
DSS 1.1, DSS 1.3, DSS 2.1 SERCOS Interface	X10	plug-in connector for LWL cable (fiber optic cable)	244 069 or 244 062	CONN. INS420 or CONN. INS425	INS420 for LWL cable INK414 with 2,2mm Ø for control encl. internal connections INS425 for LWL cable INK416 with 6.0mm Ø or for connetions internal to control enclosure (plug-in connector with use of ready-made LWL cable IKO... not needed)
	X11	plug-in connector for LWL cable	244 069 or 244 062	CONN. INS420 or CONN. INS425	
	X12	9 pin plug-in terminal	241 591	CONN.-KL3,81 F MC 1,5/ 9ST B 1-9	
DAE 1.1 ANALOG Interface with incremental encoder emulator	X13	10 pin plug-in terminal	241 647	CONN.-KL3,81 F MC 1,5/10ST B 1-10	
	X14	15 pin Dsub, female	231 714	CONN. INS289	
DAA 1.1 ANALOG Interface with absolute encoder emulator	X15	10 pin plug-in terminal	241 647	CONN.-KL3,81 F MC 1,5/10ST B 1-10	
	X16	15 pin Dsub, female	231 714	CONN. INS289	
DZF 1.1 gear toothed interface	X20	15 pin Dsub, male	231 715	CONN. INS290	
DLF 1.1 high-resolution position interface (Sine signal)	X23	15 pin Dsub, male	231 715	CONN. INS290	
DEF 1.1 incremental position interface (squarewave signal)	X22	15 pin Dsub, male	231 715	CONN. INS290	
DEF 2.1 incremental position interface (squarewave signal)	X24	15 pin Dsub, male	231 715	CONN. INS290	
DEA 4.1 Inputs/outputs (I/O) module	X17	37 pin Dsub, female	231 718	CONN. INS293	
DEA 5.1 Inputs and outputs (I/O) module	X32	37 pin Dsub, female	231 718	CONN. INS293	
DEA 6.1 Inputs/outputs (I/O) module	X33	37 pin Dsub, female	231 718	CONN. INS293	
DLC 1.1 Positioning module	X30	ready-made cable			ready-made cable IKS 745/... for programing and display unit (max. length 30m)
	X31	9 pin Dsub, male	231713	CONN. INS288	

5. Order Informationen

Components	Conn. strip	Name of plug-in connector	Part number	Text	Comment
DRF 1.1 analog signal interface	X36	15 pin Dsub, male	231 715	CONN. INS290	
DBS 1.1 Interbus S Interface	X37	9 pin Dsub, female	259 762	CONN. INS526	
	X38	9 pin Dsub, male	259 759	CONN. INS525	
CLC-D 1.1 cont. card	X25	plug-in conn. for LWL cable	244 069 or 244 062	CONN. INS420 or CONN. INS425	INS420 for LWL cable INK414 with 2.2mm Ø for control encl. connections internal
	X26	plug-in conn. for LWL cable	244 069 244 062	CONN. INS420 or CONN. INS425	
	X27	9 pin Dsub, male	257 044	CONN. INS454	
	X28	9 pin Dsub, male	257 044	CONN. INS454	
	X29	2 pin plug-in terminal	253 897	STECK-KL3,81 F MC 1,5/ 2ST B 1-2	
DFF 1.1 Single-turn encoder Interface	X18	15 pin Dsub, male	231 715	CONN. INS290	
	X19	15 pin Dsub, female	231 714	CONN. INS289	

5.3. Item List

Pos.	Article	Selection
1.	Drive controller DDC 1.2-.....-.....-	Selection data
1.1	Firmware FW . . .	Ask your local INDRAMAT- Sales Rep.
1.2	Power connection Ready-made cable IK. .../.. or Connector INS ... and cable INK ... /..	3.4
1.3	Motor power cable ready-made cable IK. .../.. or cable INK ... /.. ; motor side Connector INS ... and machine side Connector INS ...	3.9
1.4	Connection to NC control ready-made cable IKS 083/.. or connector INS 478 and cable INK 271	
1.5	Motor feedback cable ready-made cable IKS 374/.. or cable INK 209/.. ; motor side Connector INS 513 and machine side Connector INS 290 (Note: the connector INS 290 is part of connector kit S.- DDS 2)	
2.0	Conneting accessories for machine configuration Ready-made cable or connector kit S.-DDS 2	Documentation for the plug-in module 5.2
3.0	Transformer	3.2, 3.5, ..., 3.8

6. Index

Symbole

15 inputs 9

16 outputs 9

A

Absolute encoder emulator 8

Accessories for Connections 47

Additional protective device 29

Advantage when replacing unit 9

Alphanumeric display 7

Ambient Conditions 11

ANALOG interface 8

Autotransformers 19

Autotransformers in IP 55 housing 19

Auxiliary Plug-In Cards 9

B

B6 switches 40

Basic unit 6

Bb contact 37

Bend radii of INDRAMAT cables 44

Bleeder Prewarning 37

Bleeder resistor 45

C

Cable for three-phase connections 18

Circuit breakers 7

Command Interface Card 8

Connected load 15

Connecting accessories 26

Connection voltage 15

Connector assignments for DSF and RSF 27

Conneting accessories 25

Continuous bleeder power 39

D

Data Sheet 11

DC bus converter 6

DC bus dynamic brake 36

DC bus dynamic braking 7

DDC 1.1 terminal diagram 13

DDC 1.2 6

DDC 1.2-N - dimensional data 41

DEA 32

DEA 5.1 9

DEA 6.1 9

DEF 1.1 9

Digital AC Drive 5

Digital servo feedback 27

DLC 1.1 8

DLC single-axis positioning module 32

DLC single-axis positioning module 34
DLF 1.1 9
DLT Three-Phase Isolating Transformers 21
Drive controller configuration 6
Drive enable 30, 34
DSF 27
DSM 2.1 9
DSS 1.1 8
DSS 1.3 8
DST ... /G/ type transformers 19
DST Three-Phase Autotransformers 20
Duplication 9
Dynamic Braking 29, 30

E

E mode of installation 18, 24
E-stop 30, 34
E-Stop Relays 34
Electrical Connections 13
EN 60204 24
Exchanging binary signals 9

F

Fault Current Protective Device 40
Feedback Connection 27
FI current limiting circuit breakers 40
Frequency 15
Fuses 7

G

gL class fuses 17
Grounded threephase systems 16
Grounding the Supply System 16

H

High-resolution positioning interface 9
High-Voltage Testing 40
Holding brakes 23, 29, 32
Humidity 11

I

IKL 232 18
IKL 241 18
IKL 243 18
IKL 244 18
IKL 245 18
Increased ambient temperatures 12
Incremental encoder emulator 8
Incremental position interface 9
Individual cable parts 23
Individual IP 65 connectors 47
Inductance motors 29
INK 202 18
INK 203 18
INK 204 18

INK 205 18
INK 206 18
INK 250 18
INK 391 39
Input/output interface 9
Inrush current limit 7
Installation above 1000 meters 12
Interface to NC Control Unit 28
IP 00 19
IP65 6
Isolating transformers 19
Isolation transformer 17

K

K1 30, 32, 34
K3 30, 32, 34
K4 30, 32, 34

M

Machine-dependent values 9
Mains Contactor 29
Maximum cable length 23, 27
Minimum Clearances 44
Motor power cable capacity 24

N

Non-periodic overvoltages 16

O

Operating Conditions 12
Operating principles 30
Operating software 9
Outputs AK1 and AK2 38

P

PC with a VT 100 emulation program 39
Permissible overvoltage levels 16
Positioning module 8
Power Connection Diameters and Fuses 17
Power Connections 43
Power OFF 36
Power ON 36
Power shutoff 7
Power supply cable 19

R

Radio interference transmission 23
Reading Drive Parameters 39
Ready state 37
Ready-made cables 23
Ready-made INDRAMAT cables 18
Regenerated Power 39
Resolver feedback 27
rf interference suppression 23
Rotary drive energy 39

RS 232 Interface 39

RSF 27

S

Safety Clearances 45

SERCOS interface 8

SERCOS interface DSS card 8

Service life 44

Signal and Diagnostics Outputs 37

Signal path diagram 32

Signal Voltages 38

Slow-blow fuses 17

Soft start 36

Software Module 9

SSI standards 8

Standard software module 9

Supply line diameters 15

T

Technical Data 11

Terminal X4 27

Three-Phase Autotransformers 22

TN mains 16

Transformers 19

TT mains 16

Type Codes 46

U

U1 6

U5 6

UD contact 37

Ungrounded threephase systems 16

User-specific parameters 9

V

VT 100 terminal 39

X

X5 43

X7 43

X8 43

Z

Zero potential contact 37

